



Image for illustration purposes only.

### Output Ratings

Voltage, Frequency	Prime	Standby
400V, 50 Hz	135.0 kVA / 108.0 kW	150.0 kVA / 120.0 kW
480V, 60 Hz	150.0 kVA / 120.0 kW	165.0 kVA / 132.0 kW

Ratings at 0.8 power factor.

Please refer to the output ratings technical data section for specific generator set outputs per voltage.

### Prime Rating

These ratings are applicable for supplying continuous electrical power (at variable load) in lieu of commercially purchased power. There is no limitation to the annual hours of operation and this model can supply 10% overload power for 1 hour in 12 hours.

### Standby Rating

These ratings are applicable for supplying continuous electrical power (at variable load) in the event of a utility power failure. No overload is permitted on these ratings. The alternator on this model is peak continuous rated (as defined in ISO 8528-3).

### Standard Reference Conditions

Note: Standard reference conditions 25°C (77°F) Air Inlet Temp, 100m (328 ft) A.S.L. 30% relative humidity.  
Fuel consumption data at full load with diesel fuel with specific gravity of 0.85 and conforming to BS2869: 1998, Class A2.

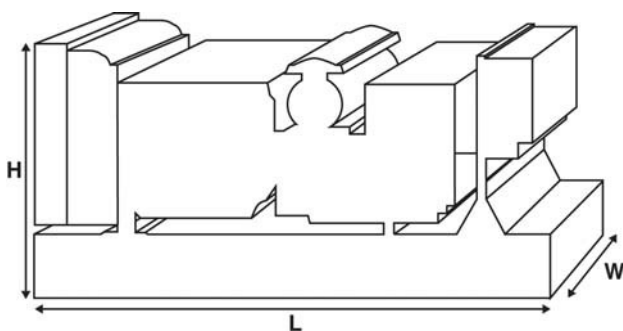

### Ratings and Performance Data

Engine Make & Model:	Perkins 1106A-70TG1	
Alternator manufactured by:	Marelli	
Alternator Model:	MJB 225 LA4	
Control Panel:	DCP-10	
Base Frame:	Heavy Duty Fabricated Steel	
Circuit Breaker Type:	3 Pole MCCB	
Frequency:	50 Hz	60 Hz
Engine Speed: rpm	1500	1800
Fuel Tank Capacity: litres (US gal)	327 (86.4)	
Fuel Consumption: l/hr (US gal/hr)		
(100% Load)	- Prime	29.9 (7.9) 33.1 (8.7)
	- Standby	33.4 (8.8) 36.7 (9.7)

### Available Options

Options include:

- Upgrade to CE Certification
- A wide range of Sound Attenuated Enclosures
- A variety of generator set control and synchronising panels
- Additional alarms and shutdowns
- A selection of exhaust silencer noise levels

For further information on all of the standard and optional features accompanying

### Dimensions and Weights

Length (L) mm (in)	Width (W) mm (in)	Height (H) mm (in)	Dry kg (lb)	Wet kg (lb)
2450 (96.5)	1010 (39.8)	1544 (60.8)	1407 (3102)	1428 (3148)

Dry = With Lube Oil

Wet = With Lube Oil and Coolant

Ratings in accordance with ISO 8528, ISO 3046, IEC 60034, BS5000 and NEMA MG-1.22. Generator set pictured may include optional accessories.

Engine Technical Data		
No. of Cylinders / Alignment:	6 / In Line	
Cycle:	4 Stroke	
Bore / Stroke: mm (in)	105.0 (4.1)/135.0 (5.3)	
Induction:	Turbocharged	
Cooling Method:	Water	
Governing Type:	Mechanical	
Governing Class:	ISO 8528 G2	
Compression Ratio:	18.2:1	
Displacement: l (cu. in)	7.0 (427.8)	
Moment of Inertia: kg m <sup>2</sup> (lb/in <sup>2</sup> )	1.40 (4784)	
Engine Electrical System:		
- Voltage / Ground	12/Negative	
- Battery Charger Amps	65	
Weight: kg (lb)	- Dry	725 (1598)
	- Wet	748 (1649)

Performance	50 Hz	60 Hz
Engine Speed: rpm	1500	1800
Gross Engine Power: kW (hp)		
- Prime	123.7 (166.0)	140.5 (188.0)
- Standby	136.9 (184.0)	155.4 (208.0)
BMEP: kPa (psi)		
- Prime	1411.0 (204.6)	1336.0 (193.7)
- Standby	1562.0 (226.5)	1477.0 (214.2)

Fuel System					
Fuel Filter Type:	Replaceable Element				
Recommended Fuel:	Class A2 Diesel or BSEN590				
Fuel Consumption: l/hr (US gal/hr)					
	110%	100%	75%	50%	
Prime	Load	Load	Load	Load	
50 Hz	33.4 (8.8)	29.9 (7.9)	22.6 (6.0)	16.2 (4.3)	
60 Hz	36.7 (9.7)	33.1 (8.7)	25.5 (6.7)	19.7 (5.2)	
		100%	75%	50%	
Standby		Load	Load	Load	
50 Hz		33.4 (8.8)	24.9 (6.6)	17.6 (4.6)	
60 Hz		36.7 (9.7)	27.5 (7.3)	20.7 (5.5)	

(Based on diesel fuel with a specific gravity of 0.85 and conforming to BS2869, Class A2)

Air Systems	50 Hz	60 Hz
Air Filter Type:	Paper Element	
Combustion Air Flow: m <sup>3</sup> /min (cfm)		
- Prime	7.6 (270)	11.0 (387)
- Standby	8.1 (286)	11.5 (405)
Max. Combustion Air Intake Restriction: kPa (in H <sub>2</sub> O)	5.0 (20.1)	5.0 (20.1)

Cooling System	50 Hz	60 Hz	
Cooling System Capacity: l (US gal)	21.0 (5.5)	21.0 (5.5)	
Water Pump Type: Centrifugal			
Heat Rejected to Water & Lube Oil:			
kW (Btu/min)	- Prime	74.9 (4259)	84.2 (4788)
	- Standby	82.0 (4663)	92.0 (5232)
Heat Radiation to Room: Heat radiated from engine and alternator			
kW (Btu/min)	- Prime	21.6 (1228)	24.1 (1371)
	- Standby	25.9 (1473)	27.0 (1535)
Radiator Fan Load: kW (hp)	5.0 (6.7)	7.0 (9.4)	
Radiator Cooling Airflow: m <sup>3</sup> /min (cfm)	228.6 (8073)	234.0 (8264)	
External Restriction to Cooling Airflow: Pa (in H <sub>2</sub> O)	125 (0.5)	125 (0.5)	

Designed to operate in ambient conditions up to 50°C (122°F).  
Contact your local FG Wilson Dealer for power ratings at specific site conditions.

Lubrication System	
Oil Filter Type:	Spin-On, Full Flow
Total Oil Capacity: l (US gal)	16.5 (4.4)
Oil Pan: l (US gal)	14.9 (3.9)
Oil Type:	API CH4 / CI4 15W-40
Oil Cooling Method:	Water

Exhaust System	50 Hz	60 Hz
Maximum Allowable Back Pressure: kPa (in Hg)	6.0 (1.8)	6.0 (1.8)
Exhaust Gas Flow: m <sup>3</sup> /min (cfm)		
- Prime	18.9 (666)	27.2 (959)
- Standby	20.5 (725)	29.1 (1026)
Exhaust Gas Temperature: °C (°F)		
- Prime	561 (1042)	526 (979)
- Standby	561 (1042)	526 (979)

Alternator Physical Data	
Manufactured by: Model:	Marelli
No. of Bearings:	MJB 225 LA4
Insulation Class:	1
Winding Pitch Code:	H
Wires:	2/3 - M0
Ingress Protection Rating:	12
Excitation System:	IP23
AVR Model:	SHUNT
	Mark V

Alternator Operating Data	
Overspeed: rpm	2250
Voltage Regulation: (Steady state)	+/- 0.5%
Wave Form NEMA = TIF:	50
Wave Form IEC = THF:	2.0%
Total Harmonic content LL/LN:	2.0%
Radio Interference:	Suppression is in line with European Standard EN61000-6
Radiant Heat: kW (Btu/min)	
- 50 Hz	10.6 (603)
- 60 Hz	12.1 (688)

Alternator Performance Data:	50 Hz				60 Hz			
	415/240V	400/230V 230/115V 200/115V	380/220V 220/110V	220/127V	480/277V 240/139V	380/220V 220/110V	240/120V 208/120V	440/254V 220/127V
Motor Starting Capability* kVA	281	260	233	307	306	195	231	262
Short Circuit Capacity** %	300	300	300	300	300	300	300	300
Reactances: Per Unit								
Xd	2.508	2.700	2.881	2.231	2.750	2.683	3.328	3.273
X'd	0.183	0.197	0.210	0.163	0.201	0.272	0.243	0.239
X''d	0.090	0.097	0.103	0.080	0.099	0.134	0.120	0.118

Reactances shown are applicable to prime ratings.  
 \*Based on 30% voltage dip at 0 power factor and SHUNT excitation.  
 \*\*With optional permanent magnet generator or AREP excitation.

Output Ratings Technical Data 50 Hz				
Voltage	Prime:		Standby:	
	kVA	kW	kVA	kW
415/240V	135.0	108.0	150.0	120.0
400/230V	135.0	108.0	150.0	120.0
380/220V	130.0	104.0	142.0	113.6
230/115V	135.0	108.0	150.0	120.0
220/127V	135.0	108.0	148.0	118.4
220/110V	130.0	104.0	142.0	113.6
200/115V	135.0	108.0	150.0	120.0

Output Ratings Technical Data 60 Hz				
Voltage	Prime:		Standby:	
	kVA	kW	kVA	kW
480/277V	150.0	120.0	165.0	132.0
220/127V	150.0	120.0	165.0	132.0
380/220V	140.0	112.0	153.0	122.4
240/120V	150.0	120.0	165.0	132.0
440/254V	150.0	120.0	165.0	132.0
220/110V	140.0	112.0	153.0	122.4
208/120V	150.0	120.0	165.0	132.0
240/139V	150.0	120.0	165.0	132.0

### Documentation

A full set of operation and maintenance manuals and circuit wiring diagrams.

### Generator Set Standards

The equipment meets the following standards: BS5000, ISO 8528, ISO 3046, IEC 60034, NEMA MG-1.22..

### Warranty

All prime equipment carries a one year manufacturer's warranty. Standby equipment, limited to 500 running hours per year, has a two year manufacturer's warranty.