

LOWER GROUND FLOOR PLAN

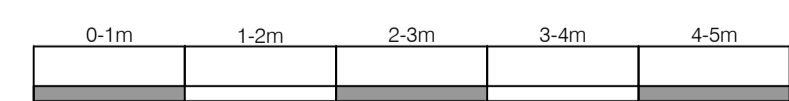

SCALE IN METERS



Notes

Copyright of this drawing and contents remain with Collett Zarzycki.
 Do not scale from drawings.
 The contractor is to verify dimensions on site prior to the commencement of work. Any discrepancies are to be reported to the Architect / Supervising Officer immediately.
 If in doubt - seek clarification.

All work must comply with the current Building Regulations and local Byelaws. No materials are to be used or method of workmanship employed unless conformity with the current Codes of the Practice & British Standards is ensured.

All levels are in metres and related to GPS.

- ah arch height
- sp springer height
- sh sill to head height
- fs floor to sill height
- uls underside height
- tls topside height
- conc concrete
- ri roof light
- cupd cupboard
- fp fireplace
- svp soil and vent pipe
- rwp rain water pipe
- 2.87 room height

Rev	Date	Notes
-----	------	-------

COLLETT~ZARZYCKI LIMITED

2B FERNHEAD ROAD LONDON W9 3ET
 TEL: 020 8969 6967 FAX: 020 8960 6480
 E-MAIL: mail@czltd.co.uk

ARCHITECTURE INTERIOR DESIGN
 FURNITURE LANDSCAPING

Job

12 PARK VILLAGE WEST

Title

EXISTING
 LOWER GROUND FLOOR PLAN

Date	Scale	Number	Rev
02.12.15	1:100 at A3 1:50 at A1	1401/P/02	

Drawing Status: PLANNING

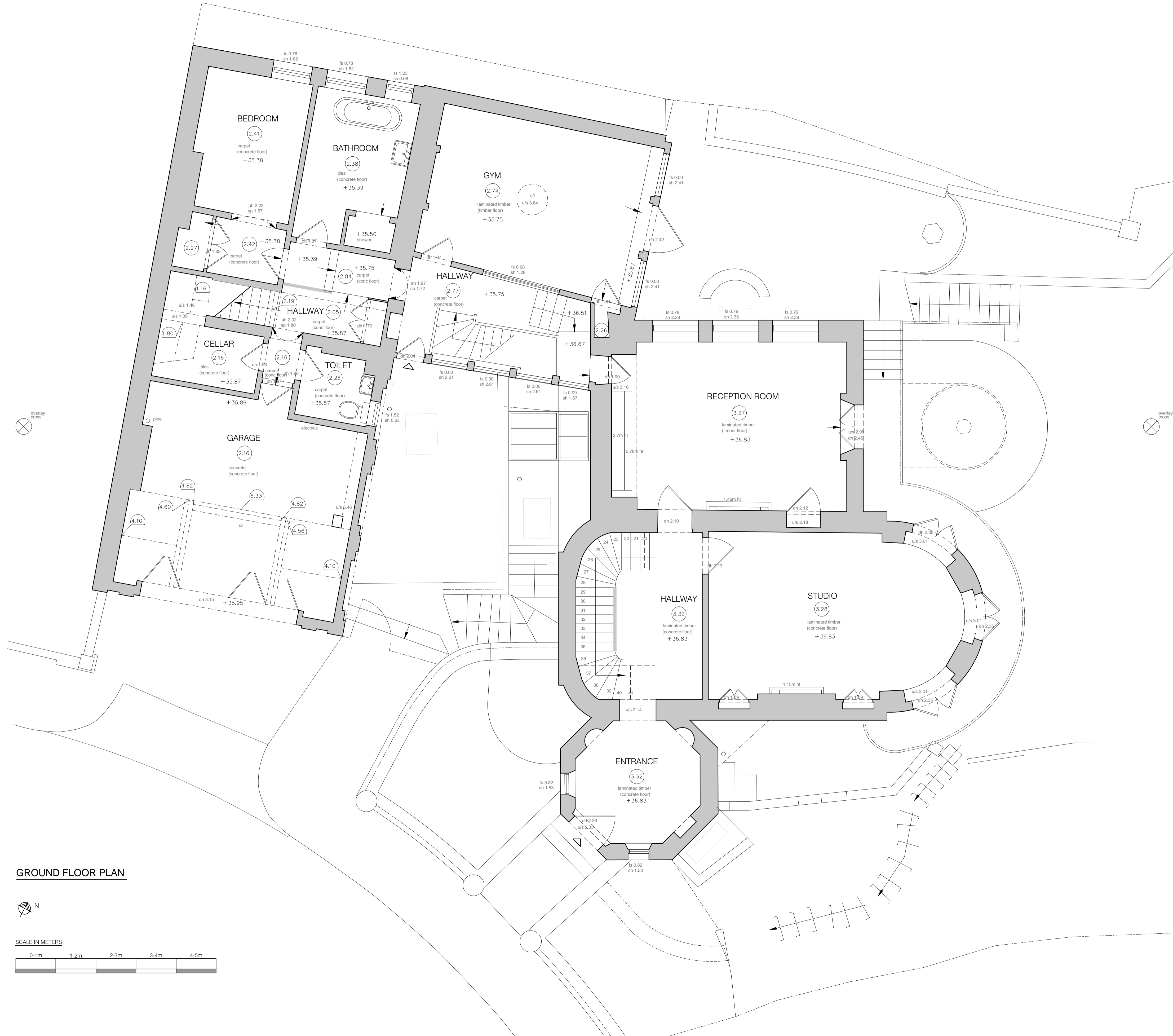

GROUND FLOOR PLAN



SCALE IN METERS

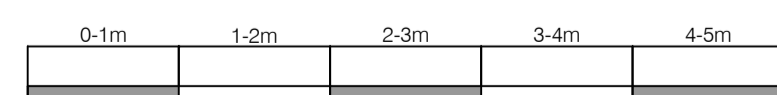

Notes

Copyright of this drawing and contents remain with Collett Zarzycki.
 Do not scale from drawings.
 The contractor is to verify dimensions on site prior to the commencement of work. Any discrepancies are to be reported to the Architect / Supervising Officer immediately.
 If in doubt - seek clarification.

All work must comply with the current Building Regulations and local Byelaws. No materials are to be used or method of workmanship employed unless conformity with the current Codes of the Practice & British Standards is ensured.

All levels are in metres and related to GPS.

- ah arch height
- sp springer height
- sh sill to head height
- fs floor to sill height
- uls underside height
- ts topside height
- conc concrete
- ri roof light
- cuprd cupboard
- fp fireplace
- svp soil and vent pipe
- rxp rain water pipe
- 2.87 room height

Rev	Date	Notes
-----	------	-------

COLLETT-ZARZYCKI LIMITED

2B FERNHEAD ROAD LONDON W9 3ET
 TEL: 020 8969 6967 FAX: 020 8960 6480
 E-MAIL: mail@czltd.co.uk

ARCHITECTURE INTERIOR DESIGN
 FURNITURE LANDSCAPING

Job

12 PARK VILLAGE WEST

Title

EXISTING
 GROUND FLOOR PLAN

Date	Scale	Number	Rev
02.12.15	1:100 at A3 1:50 at A1	1401/P/03	

Drawing Status: PLANNING

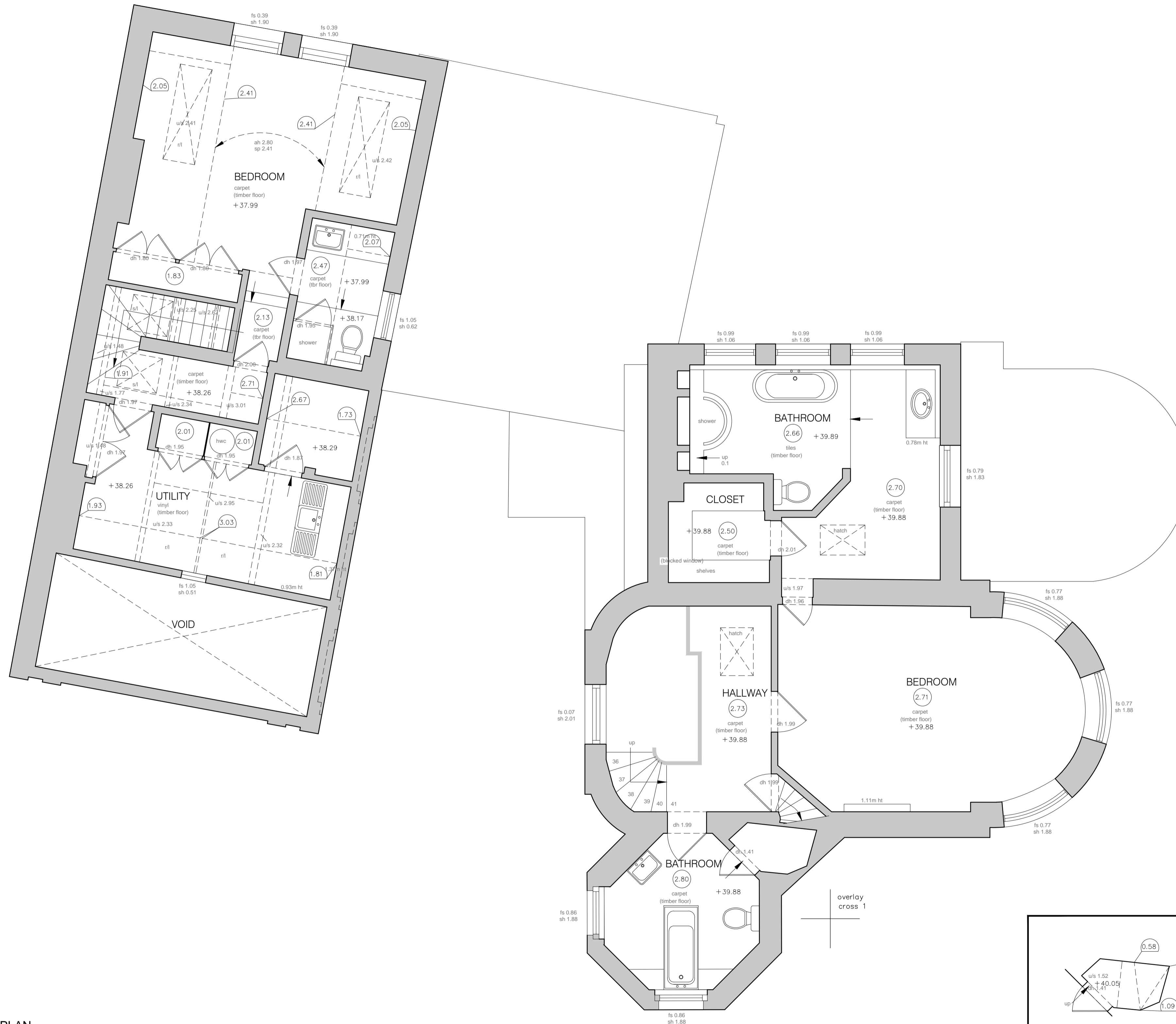

FIRST FLOOR PLAN



SCALE IN METERS

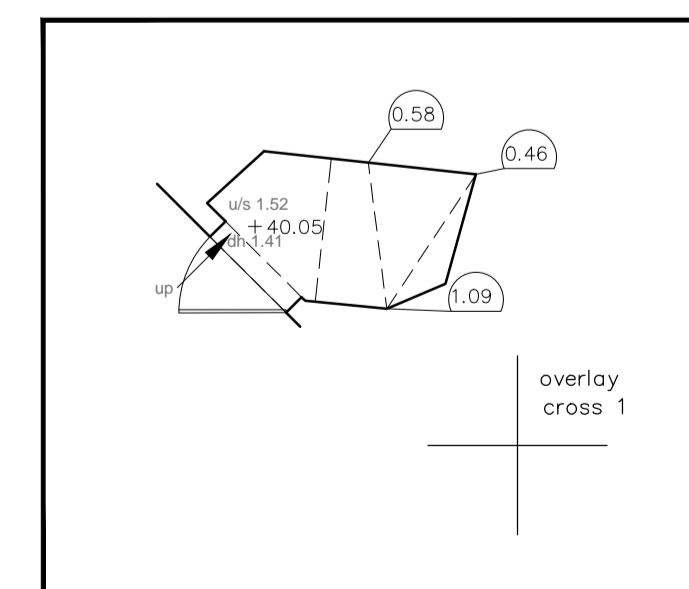
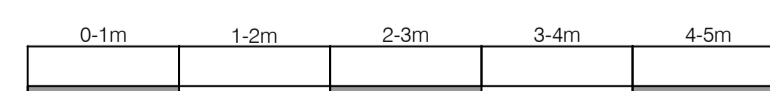

Notes

Copyright of this drawing and contents remain with Collett Zarzycki.

Do not scale from drawings.
The contractor is to verify dimensions on site prior to the commencement of work. Any discrepancies are to be reported to the Architect / Supervising Officer immediately.

If in doubt - seek clarification.

All work must comply with the current Building Regulations and local Byelaws. No materials are to be used or method of workmanship employed unless conformity with the current Codes of the Practice & British Standards is ensured.

- All levels are in metres and related to GPS.
- ah arch height
 - sh springer height
 - sh sill to head height
 - fs floor to sill height
 - uls underside height
 - fs topside height
 - conc concrete
 - ri roof light
 - cupbd cupboard
 - fp fireplace
 - svp soil and vent pipe
 - rwp rain water pipe
 - 2.87 room height

Rev	Date	Notes	
COLLETT~ZARZYCKI LIMITED			
28 FERNHEAD ROAD LONDON W9 3ET TEL: 020 8969 6967 FAX: 020 8960 6480 E-MAIL: mail@czltd.co.uk			
ARCHITECTURE INTERIOR DESIGN FURNITURE LANDSCAPING			
Job			
12 PARK VILLAGE WEST			
Title			
EXISTING FIRST FLOOR PLAN			
Date	Scale	Number	Rev
02.12.15	1:100 at A3 1:50 at A1	1401/P/04	
Drawing Status		PLANNING	

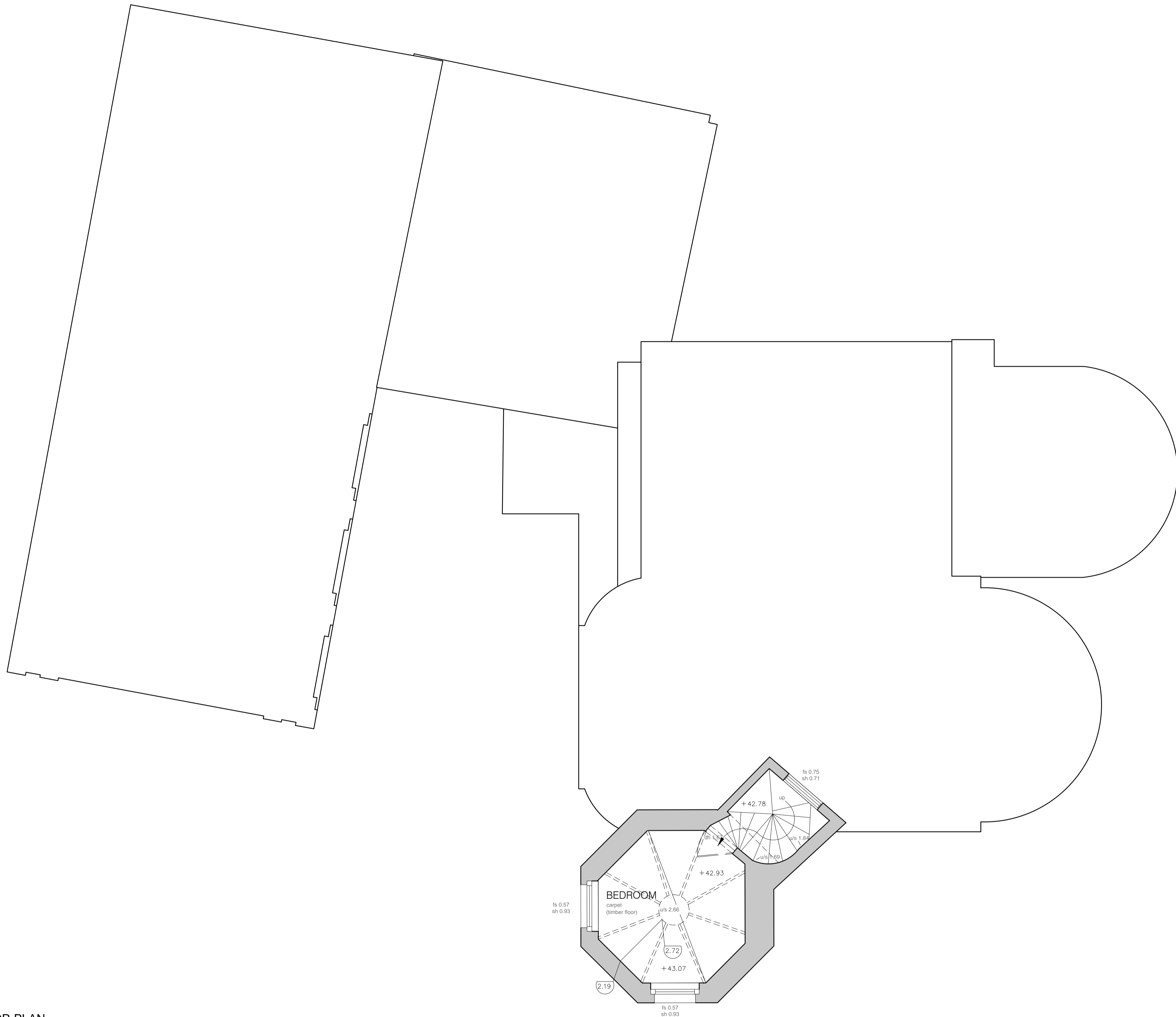

SECOND FLOOR PLAN



SCALE IN METERS

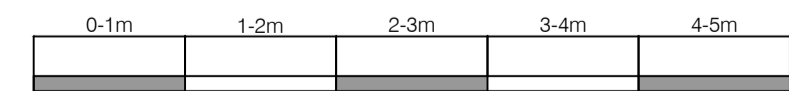

Notes

Copyright of this drawing and contents remain with Collett Zarzycki.
 Do not scale from drawings.
 The contractor is to verify dimensions on site prior to the commencement of work. Any discrepancies are to be reported to the Architect / Supervising Officer immediately.
 If in doubt - seek clarification.
 All work must comply with the current Building Regulations and local Byelaws. No materials are to be used or method of workmanship employed unless conformity with the current Codes of the Practice & British Standards is ensured.

All levels are in metres and related to GPS.

- ah arch height
- sp springer height
- sh sill to head height
- fs floor to sill height
- uls underside height
- ts topside height
- conc concrete
- rl roof light
- cupd cupboard
- fp fireplace
- svp soil and vent pipe
- rwp rain water pipe
- 2.87 room height

Rev	Date	Notes
-----	------	-------

COLLETT~ZARZYCKI LIMITED

2B FERNHEAD ROAD LONDON W9 3ET
 TEL: 020 8969 6967 FAX: 020 8960 6480
 E-MAIL: mail@czltd.co.uk

ARCHITECTURE INTERIOR DESIGN
 FURNITURE LANDSCAPING

Job

12 PARK VILLAGE WEST

Title

EXISTING
 SECOND FLOOR PLAN

Date	Scale	Number	Rev
02.12.15	1:100 at A3 1:50 at A1	1401/P/05	

Drawing Status: PLANNING

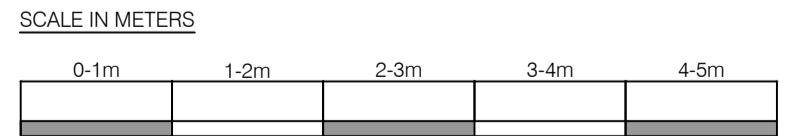
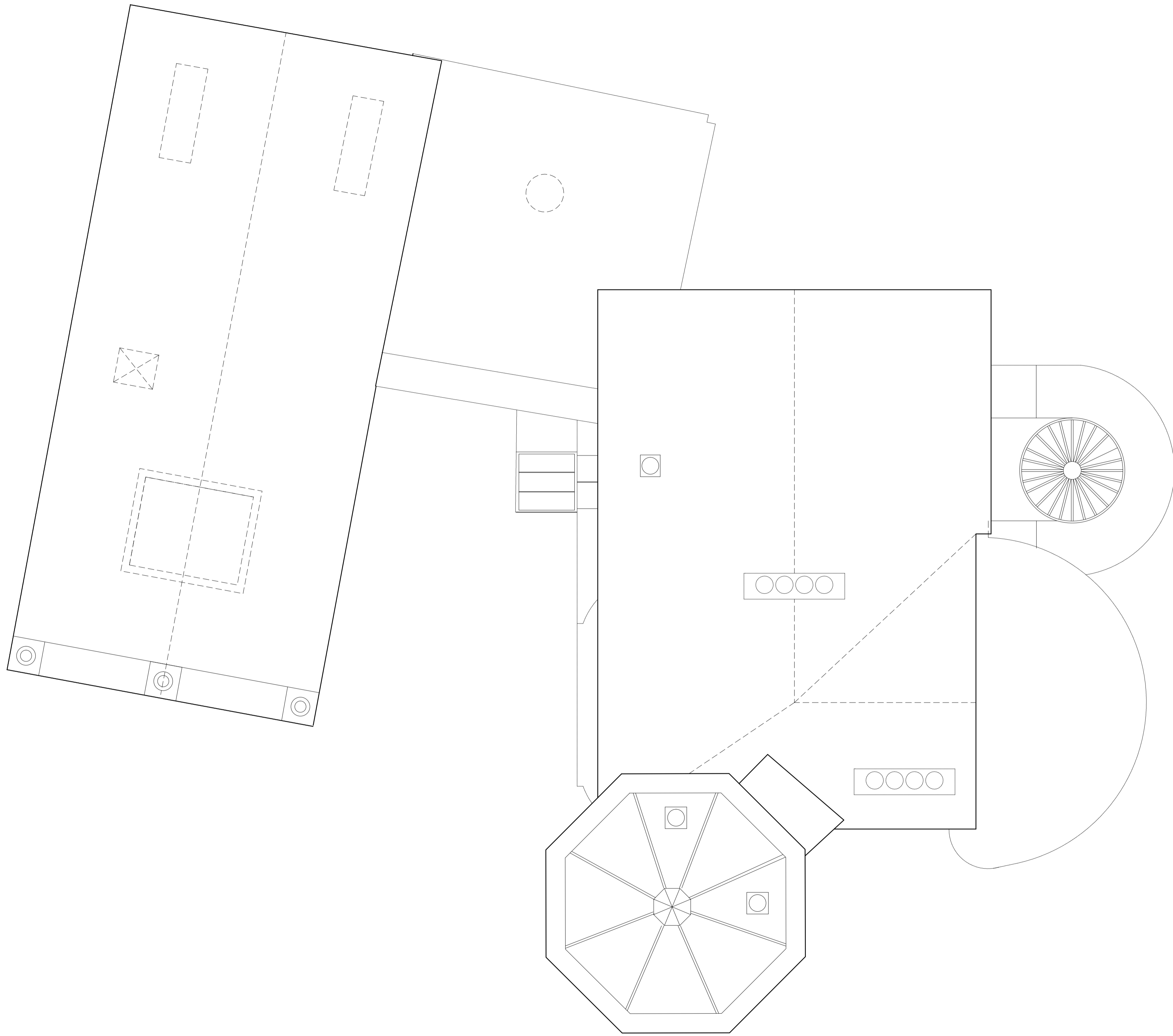

Notes

Copyright of this drawing and contents remain with Collett Zarzycki.
 Do not scale from drawings.
 The contractor is to verify dimensions on site prior to the commencement of work. Any discrepancies are to be reported to the Architect / Supervising Officer immediately.
 If in doubt - seek clarification.
 All work must comply with the current Building Regulations and local Byelaws. No materials are to be used or method of workmanship employed unless conformity with the current Codes of the Practice & British Standards is ensured.

- All levels are in metres and related to GPS.
- ah arch height
 - sp springer height
 - sh sill to head height
 - fs floor to sill height
 - uls underside height
 - ts topside height
 - conc concrete
 - rl roof light
 - cuprd cupboard
 - fp fireplace
 - svp soil and vent pipe
 - rwp rain water pipe
 - 2.87 room height

Rev	Date	Notes
-----	------	-------

COLLETT~ZARZYCKI LIMITED

2B FERNHEAD ROAD LONDON W9 3ET
 TEL: 020 8969 6967 FAX: 020 8960 6480
 E-MAIL: mail@czltd.co.uk

ARCHITECTURE INTERIOR DESIGN
 FURNITURE LANDSCAPING

Job

12 PARK VILLAGE WEST

Title

EXISTING
 ROOF PLAN

Date	Scale	Number	Rev
02.12.15	1:100 at A3 1:50 at A1	1401/P/06	

Drawing Status: PLANNING



SOUTH-EAST ELEVATION
△(32.00m A.O.D.)

SCALE IN METERS

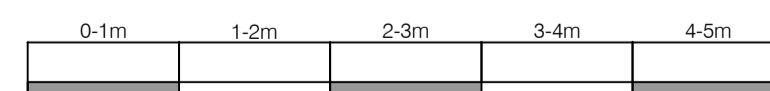

NORTH-EAST ELEVATION
△(32.00m A.O.D.)

Notes

Copyright of this drawing and contents remain with Collett Zarzycki.

Do not scale from drawings.
 The contractor is to verify dimensions on site prior to the commencement of work. Any discrepancies are to be reported to the Architect / Supervising Officer immediately.

If in doubt - seek clarification.

All work must comply with the current Building Regulations and local Byelaws. No materials are to be used or method of workmanship employed unless conformity with the current Codes of the Practice & British Standards is ensured.

Rev	Date	Notes
-----	------	-------

COLLETT~ZARZYCKI LIMITED

2B FERNHEAD ROAD LONDON W9 3ET
 TEL: 020 8969 6967 FAX: 020 8960 6480
 E-MAIL: mail@czhd.co.uk

ARCHITECTURE INTERIOR DESIGN
 FURNITURE LANDSCAPING

Job

12 PARK VILLAGE WEST

Title

EXISTING ELEVATIONS 1

Date	Scale	Number	Rev
02.12.15	1:100 at A3 1:50 at A1	1401/P/07	

Drawing Status **PLANNING**

Notes

Copyright of this drawing and contents remain with Collett Zarzycki.

Do not scale from drawings.
The contractor is to verify dimensions on site prior to the commencement of work. Any discrepancies are to be reported to the Architect / Supervising Officer immediately.

If in doubt - seek clarification.

All work must comply with the current Building Regulations and local Byelaws. No materials are to be used or method of workmanship employed unless conformity with the current Codes of the Practice & British Standards is ensured.



SOUTH-WEST ELEVATION
23(32.00m A.O.D.)



NORTH-WEST ELEVATION
23(32.00m A.O.D.)

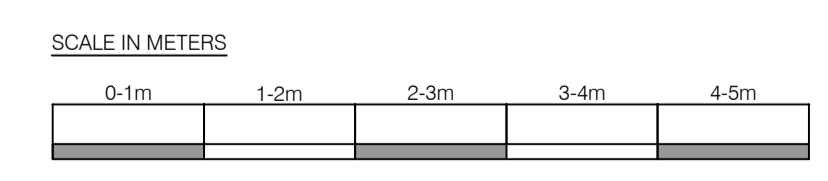

Rev	Date	Notes
-----	------	-------

COLLETT~ZARZYCKI LIMITED

2B FERNHEAD ROAD LONDON W9 3ET
TEL: 020 8969 6967 FAX: 020 8960 6480
E-MAIL: mail@czltd.co.uk

ARCHITECTURE INTERIOR DESIGN
FURNITURE LANDSCAPING

Job

12 PARK VILLAGE WEST

Title

EXISTING ELEVATIONS 2

Date	Scale	Number	Rev
02.12.15	1:100 at A3 1:50 at A1	1401/P/08	

Drawing Status **PLANNING**

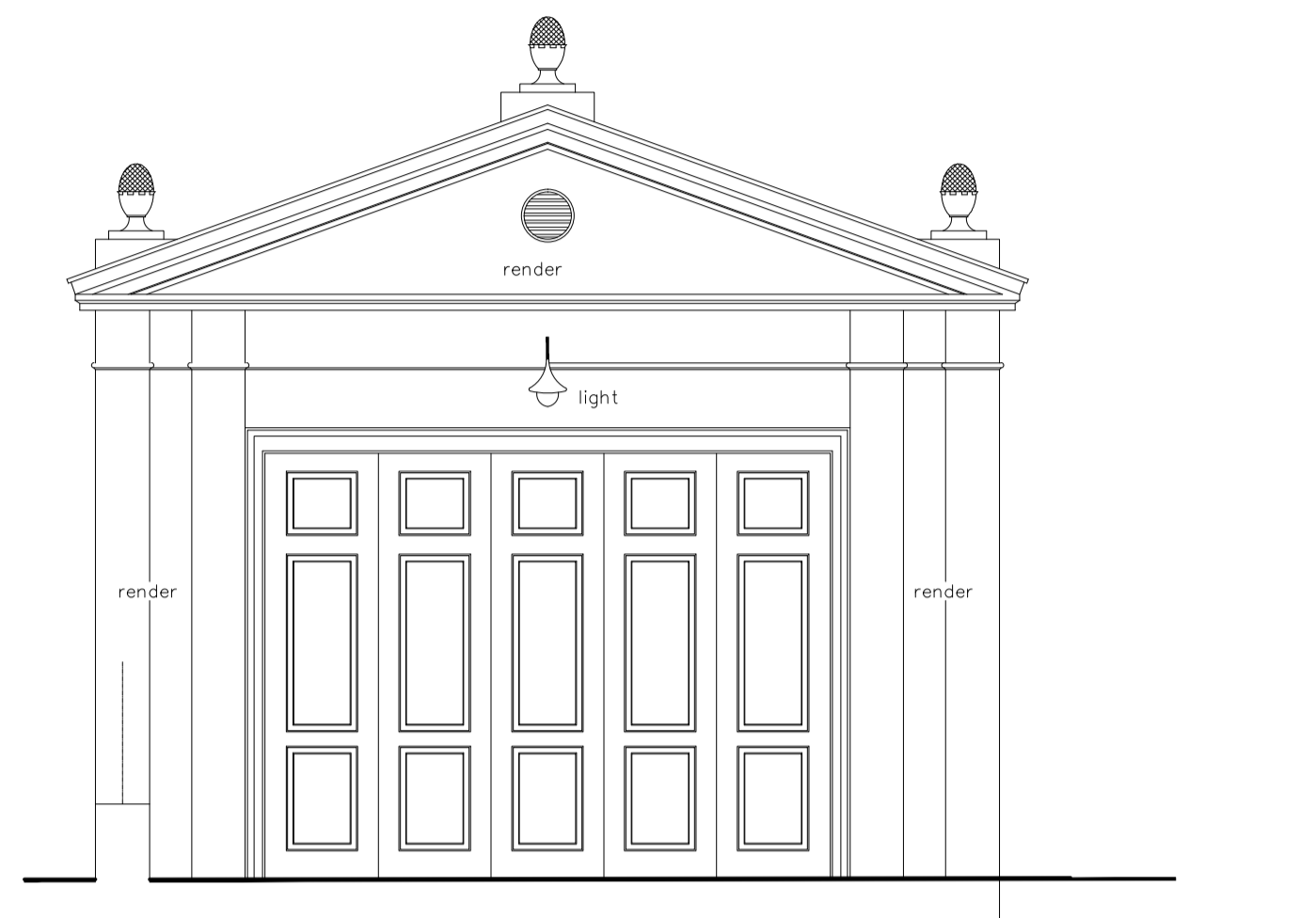

SOUTH-EAST ELEVATION

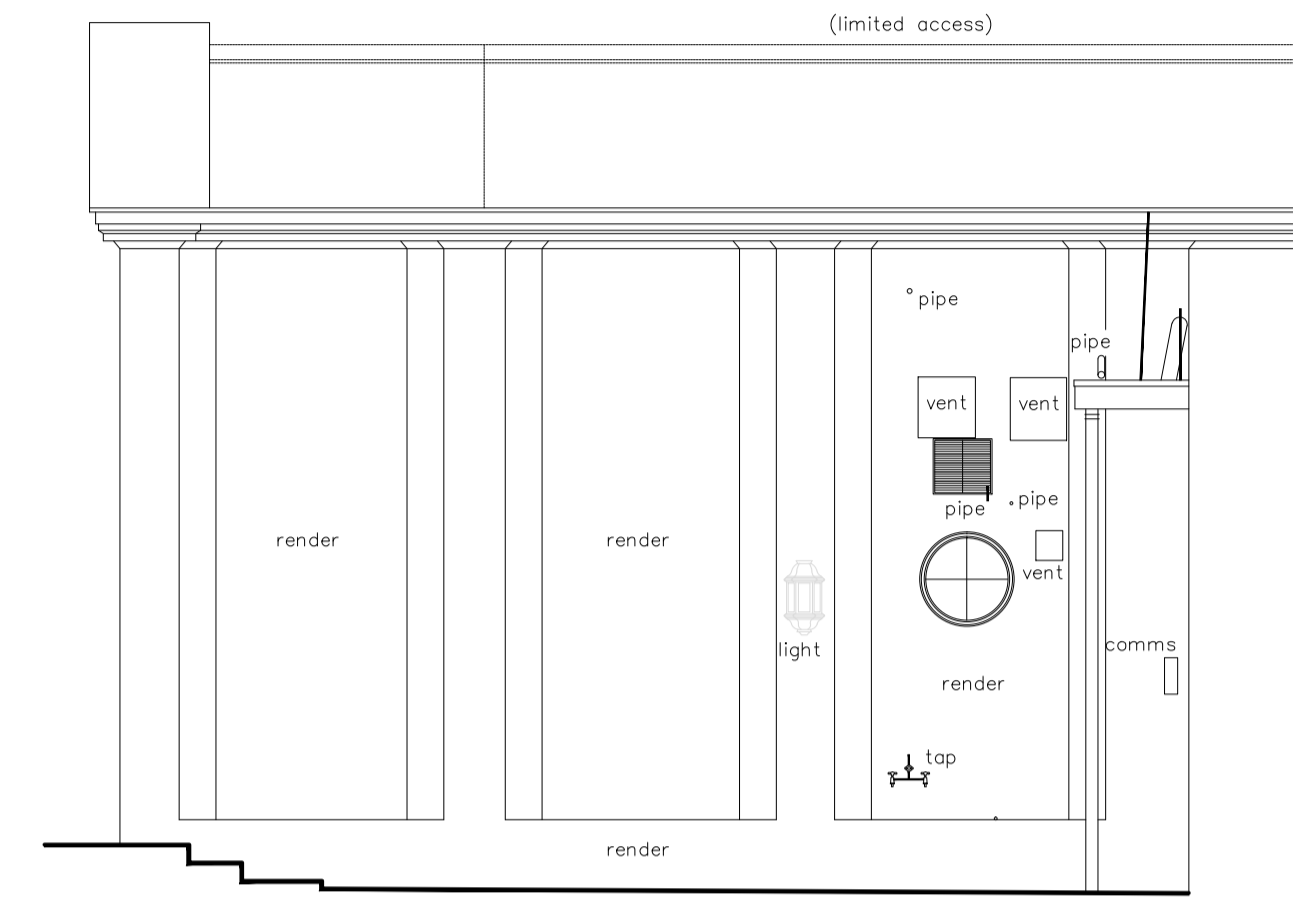

EAST ELEVATION

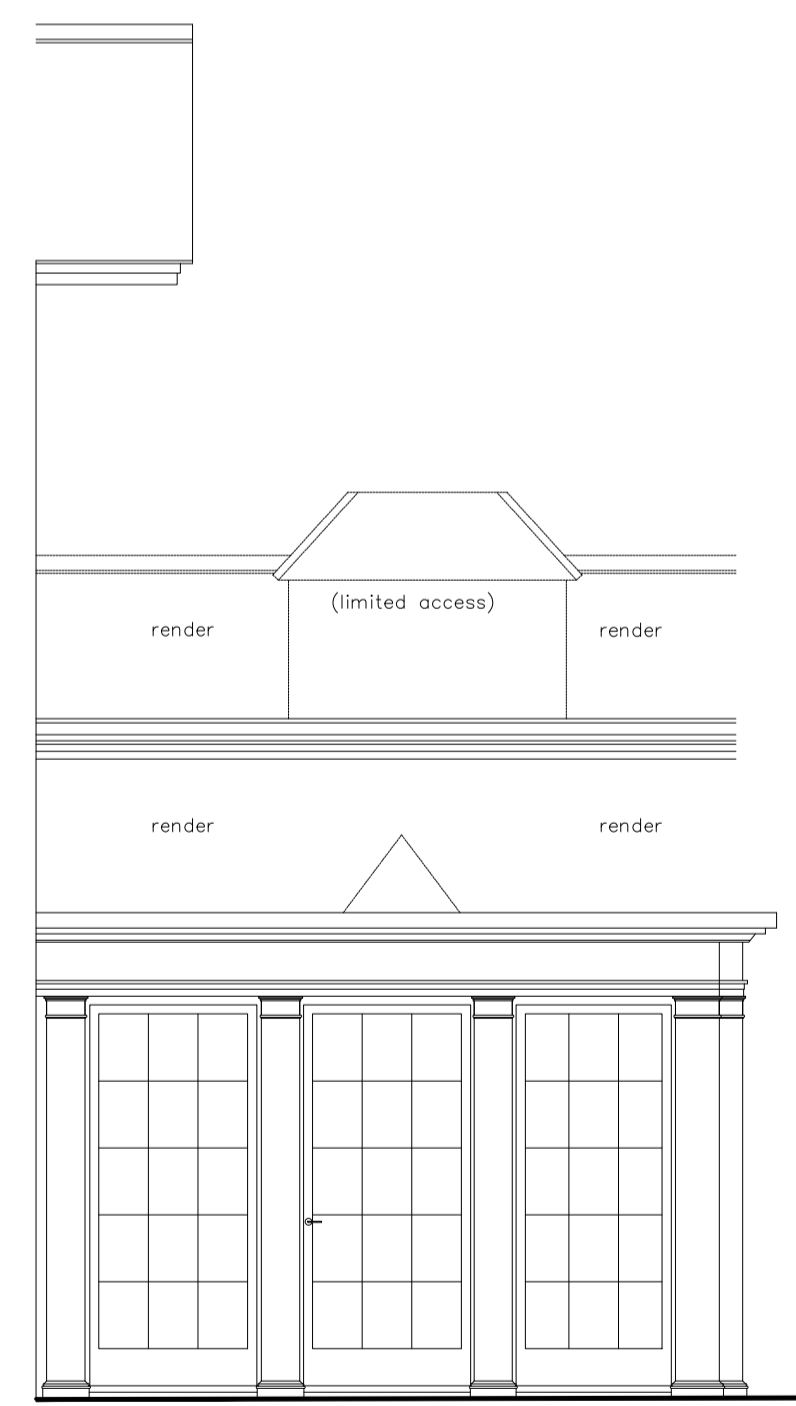

NORTH-EAST ELEVATION

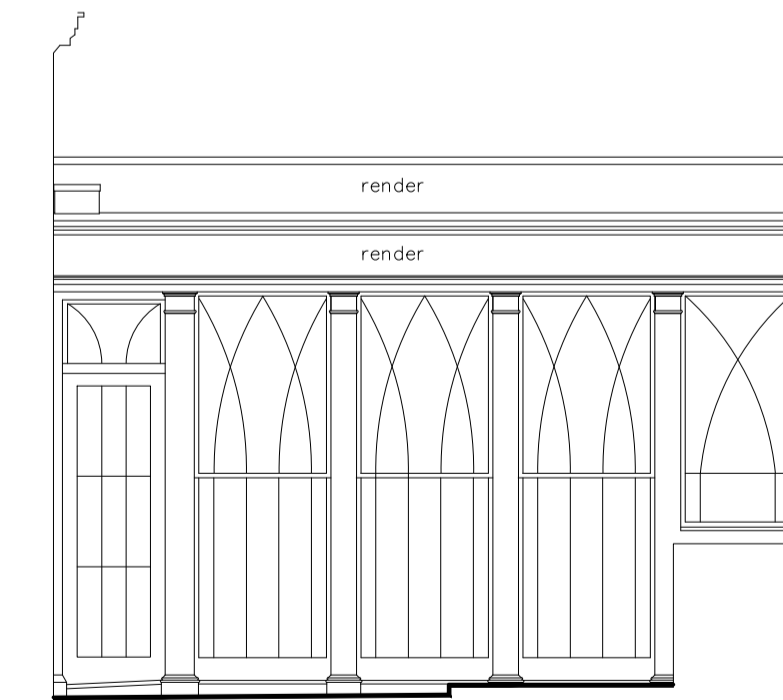

SOUTH-EAST ELEVATION

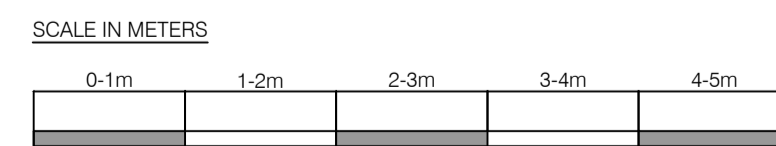

Notes

Copyright of this drawing and contents remain with Collett Zarzycki.

Do not scale from drawings.
The contractor is to verify dimensions on site prior to the commencement of work. Any discrepancies are to be reported to the Architect / Supervising Officer immediately.

If in doubt - seek clarification.

All work must comply with the current Building Regulations and local Byelaws. No materials are to be used or method of workmanship employed unless conformity with the current Codes of the Practice & British Standards is ensured.

Rev	Date	Notes
-----	------	-------

COLLETT~ZARZYCKI LIMITED

2B FERNHEAD ROAD LONDON W9 3ET
TEL: 020 8969 6967 FAX: 020 8960 6480
E-MAIL: mail@czltd.co.uk

ARCHITECTURE INTERIOR DESIGN
FURNITURE LANDSCAPING

Job

12 PARK VILLAGE WEST

Title

EXISTING
ELEVATIONS 3

Date	Scale	Number	Rev
02.12.15	1:100 at A3 1:50 at A1	1401/P/09	

Drawing Status **PLANNING**

Notes

Copyright of this drawing and contents remain with Collett Zarzycki.

Do not scale from drawings.
The contractor is to verify dimensions on site prior to the commencement of work. Any discrepancies are to be reported to the Architect / Supervising Officer immediately.

If in doubt - seek clarification.

All work must comply with the current Building Regulations and local Byelaws. No materials are to be used or method of workmanship employed unless conformity with the current Codes of the Practice & British Standards is ensured.

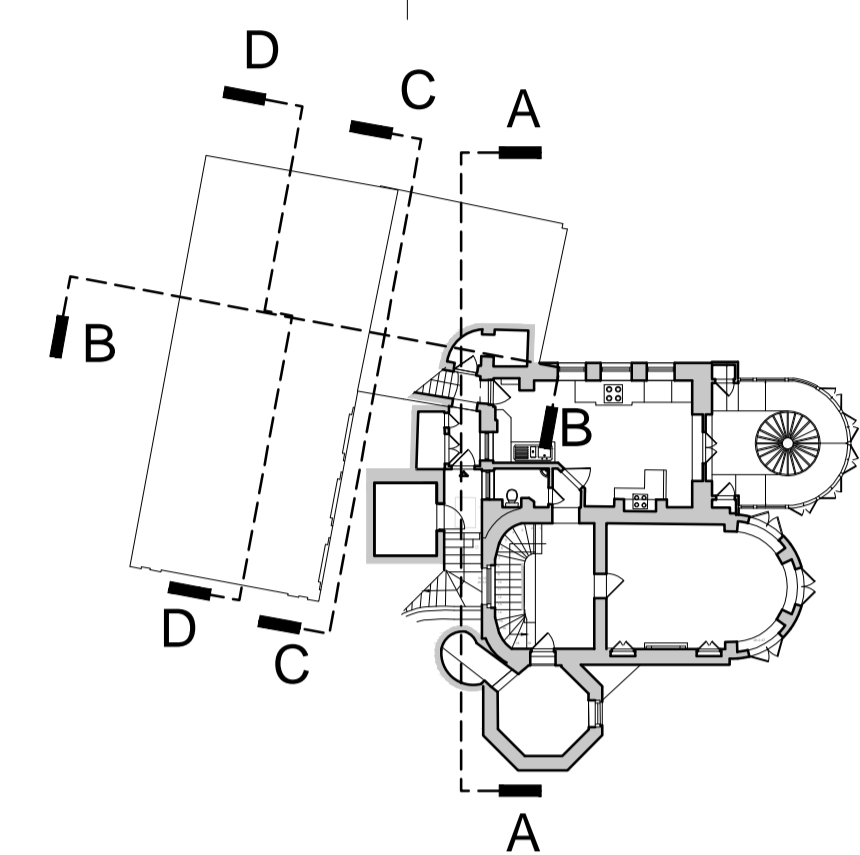

KEY PLAN



SECTION A-A Δ (32.00m A.O.D.)

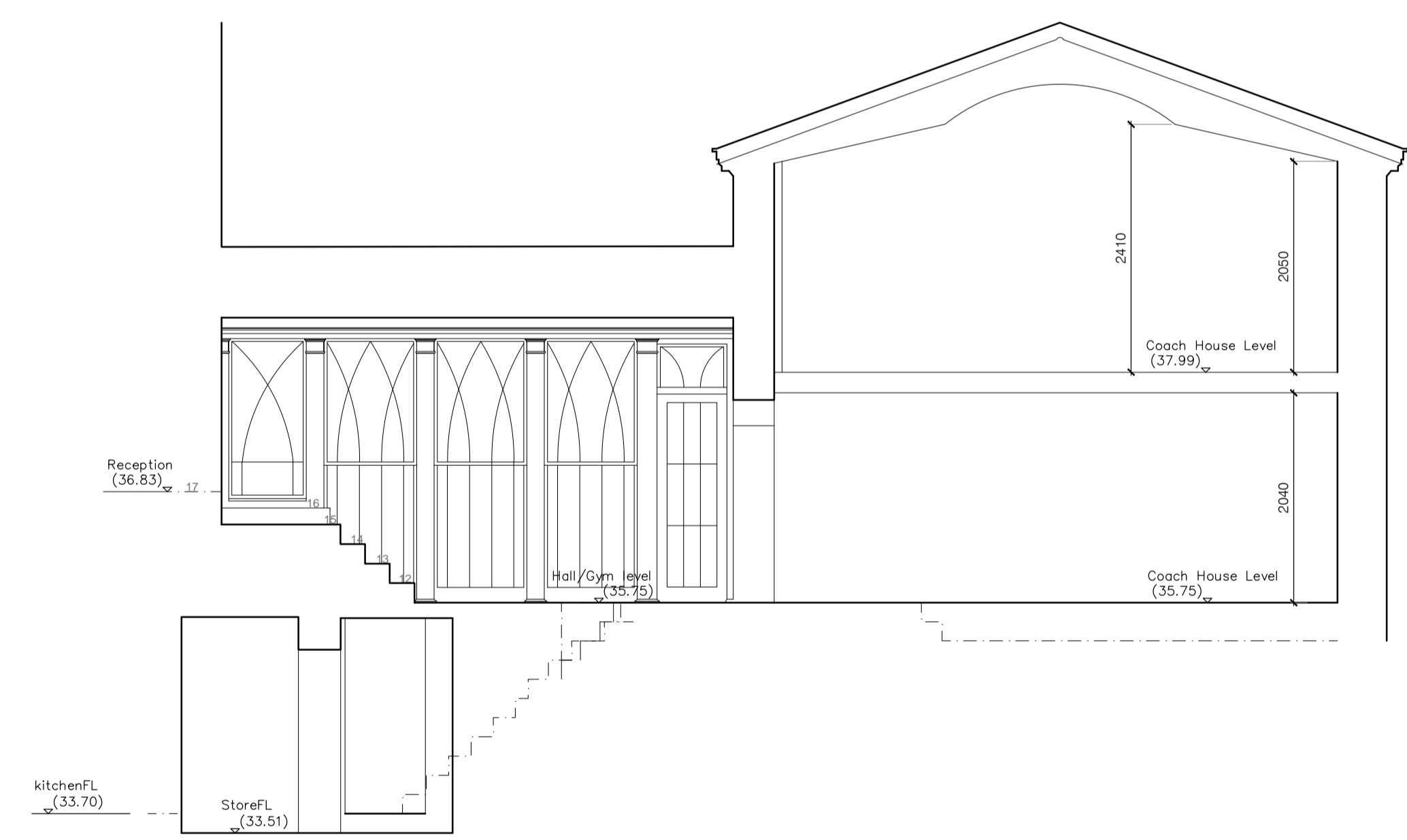

SECTION B-B Δ (32.00m A.O.D.)

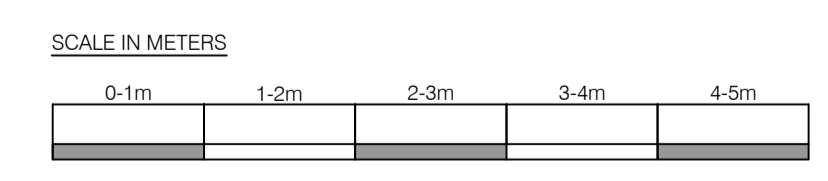

Rev	Date	Notes
-----	------	-------

COLLETT~ZARZYCKI LIMITED

2B FERNHEAD ROAD LONDON W9 3ET
TEL: 020 8969 6967 FAX: 020 8960 6480
E-MAIL: mail@czltd.co.uk

ARCHITECTURE INTERIOR DESIGN
FURNITURE LANDSCAPING

Job

12 PARK VILLAGE WEST

Title
EXISTING SECTIONS 1

Date	Scale	Number	Rev
02.12.15	1:100 at A3 1:50 at A1	1401/P/10	

Drawing Status **PLANNING**

Notes

Copyright of this drawing and contents remain with Collett Zarzycki.

Do not scale from drawings.
The contractor is to verify dimensions on site prior to the commencement of work. Any discrepancies are to be reported to the Architect / Supervising Officer immediately.

If in doubt - seek clarification.

All work must comply with the current Building Regulations and local Byelaws. No materials are to be used or method of workmanship employed unless conformity with the current Codes of the Practice & British Standards is ensured.

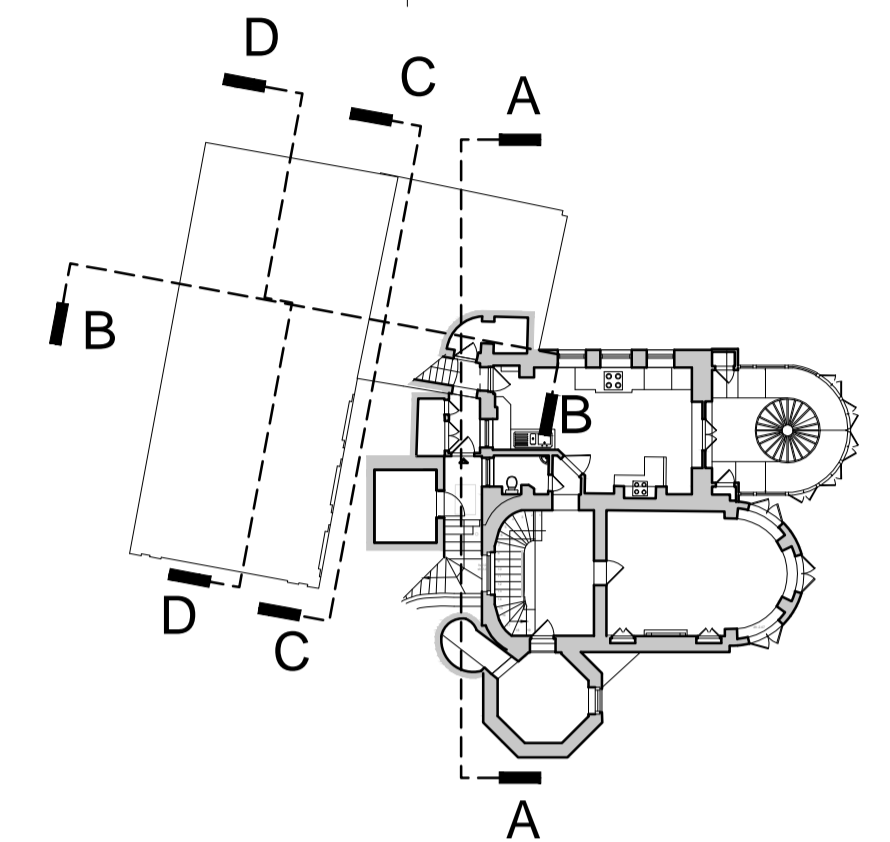

KEY PLAN

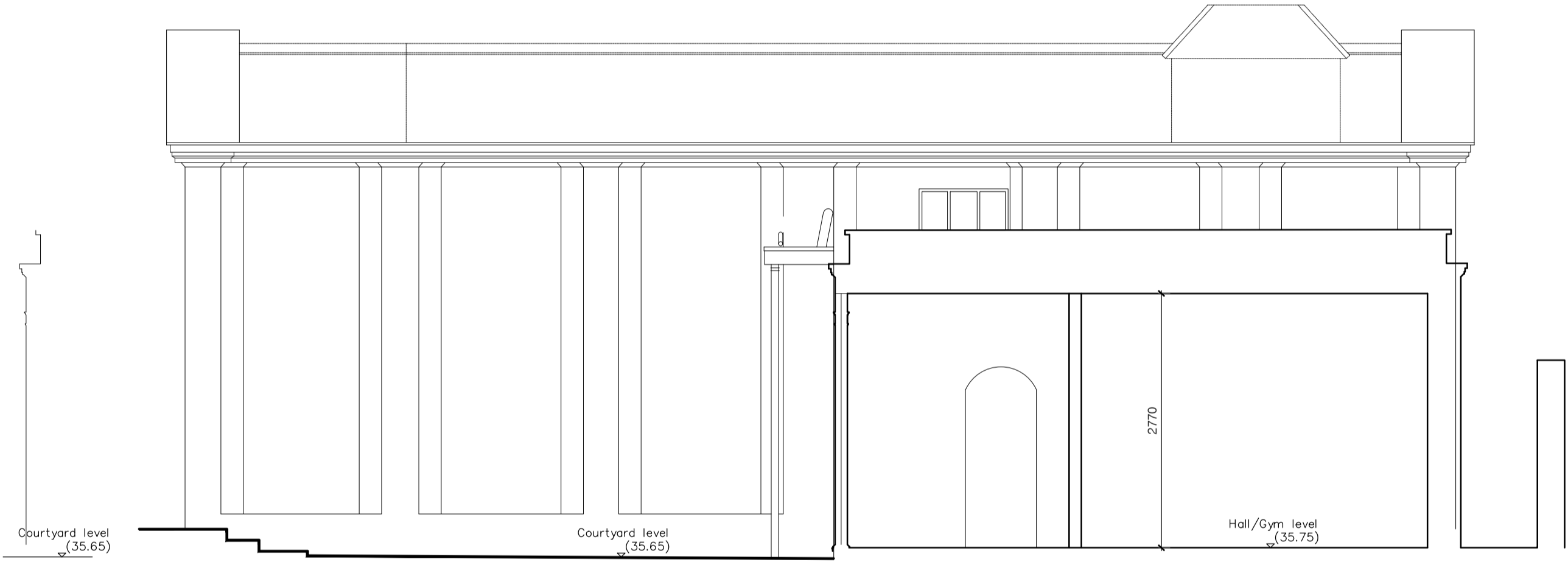

SECTION C-C
A (32.00m A.O.D.)

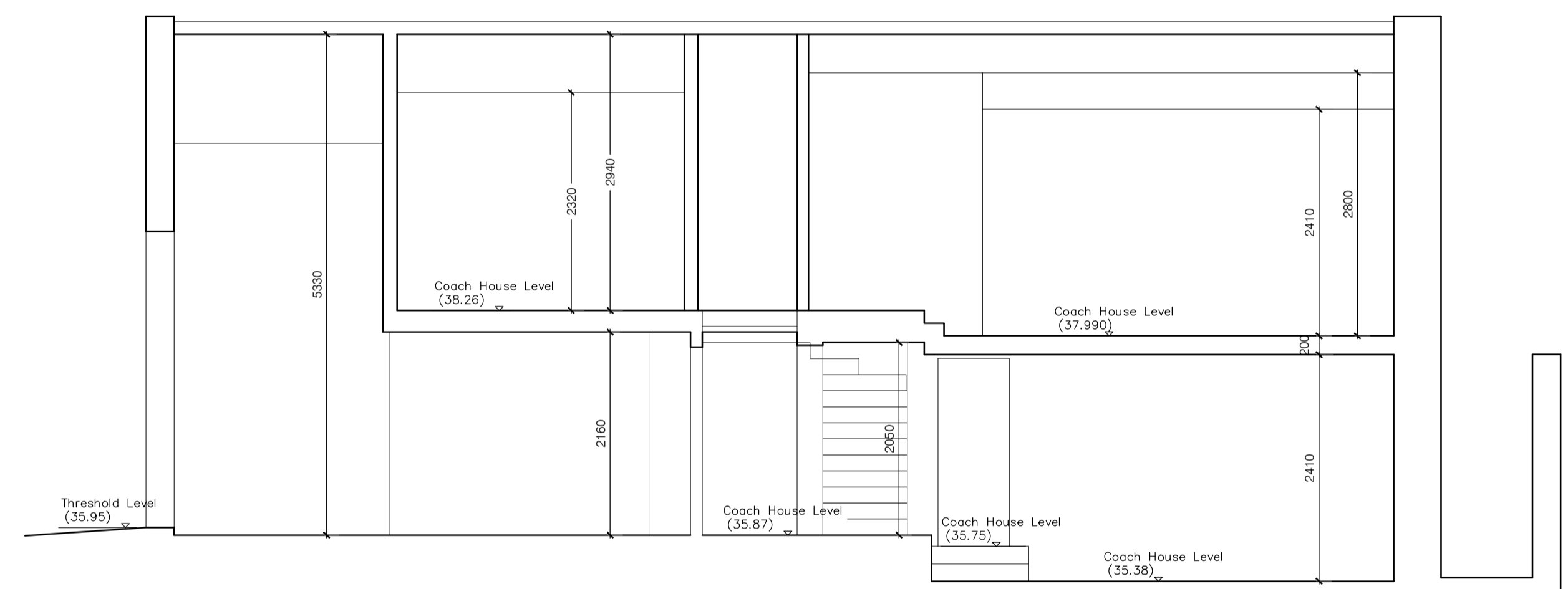

SECTION D-D
A (32.00m A.O.D.)

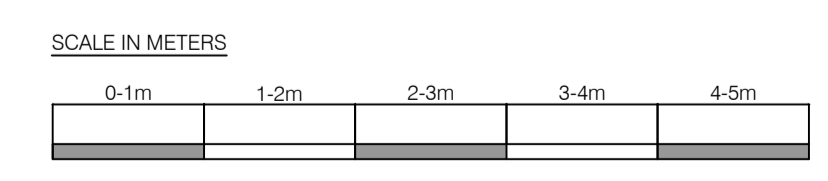

Rev	Date	Notes	
<p>COLLETT~ZARZYCKI LIMITED</p> <p>2B FERNHEAD ROAD LONDON W9 3ET TEL: 020 8969 6967 FAX: 020 8960 6480 E-MAIL: mail@czhd.co.uk</p> <p>ARCHITECTURE INTERIOR DESIGN FURNITURE LANDSCAPING</p> <p>Job</p> <p>12 PARK VILLAGE WEST</p> <p>Title</p> <p>EXISTING SECTIONS 2</p>			
Date	Scale	Number	Rev
02.12.15	1:100 at A3 1:50 at A1	1401/P/11	
Drawing Status		PLANNING	