

WG06 - Bi-fold doors

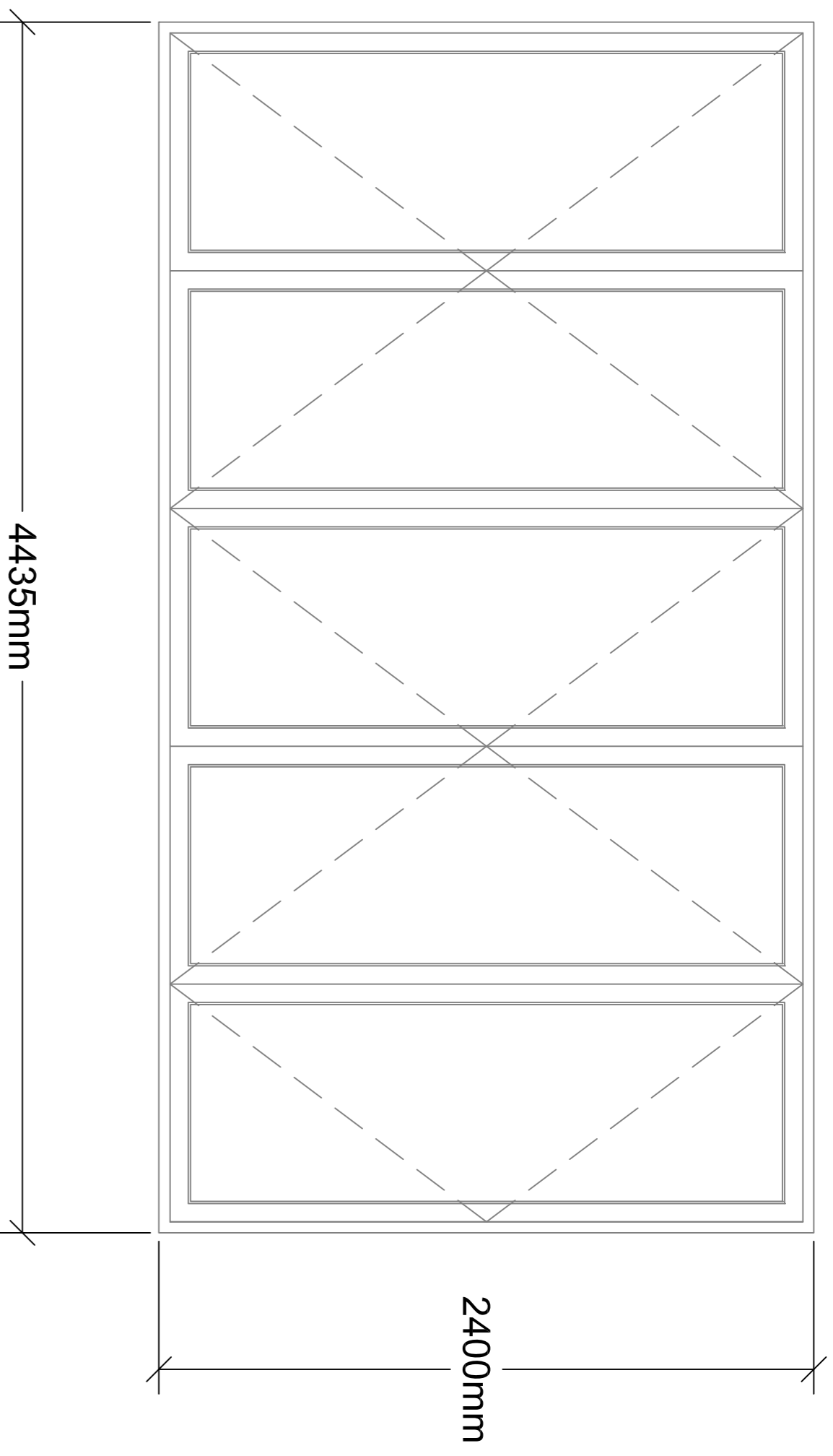

WG07 - Sliding doors

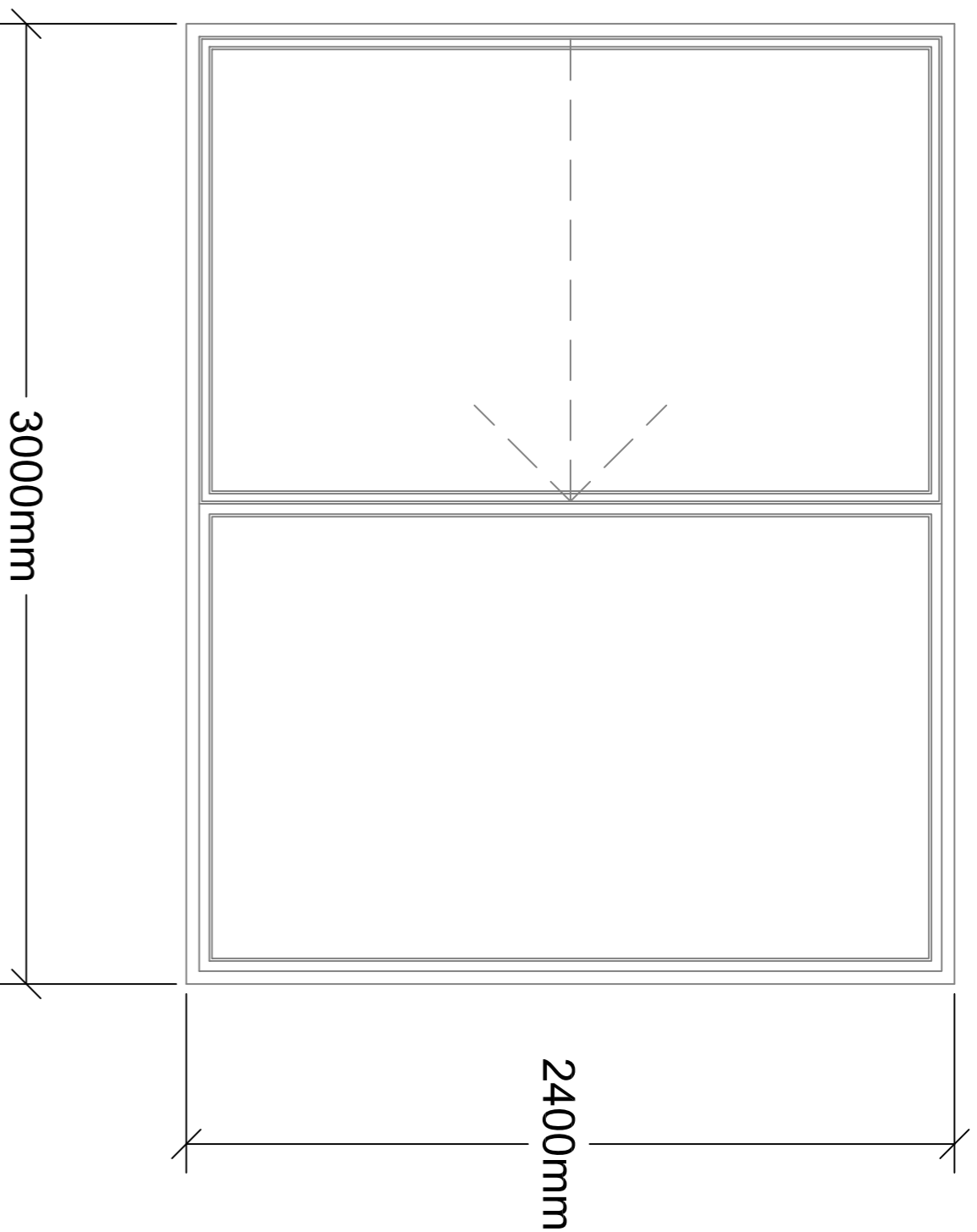

WG08

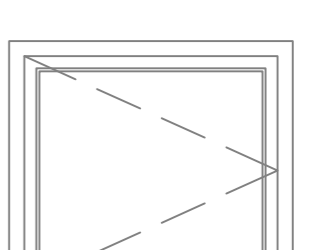

WG09

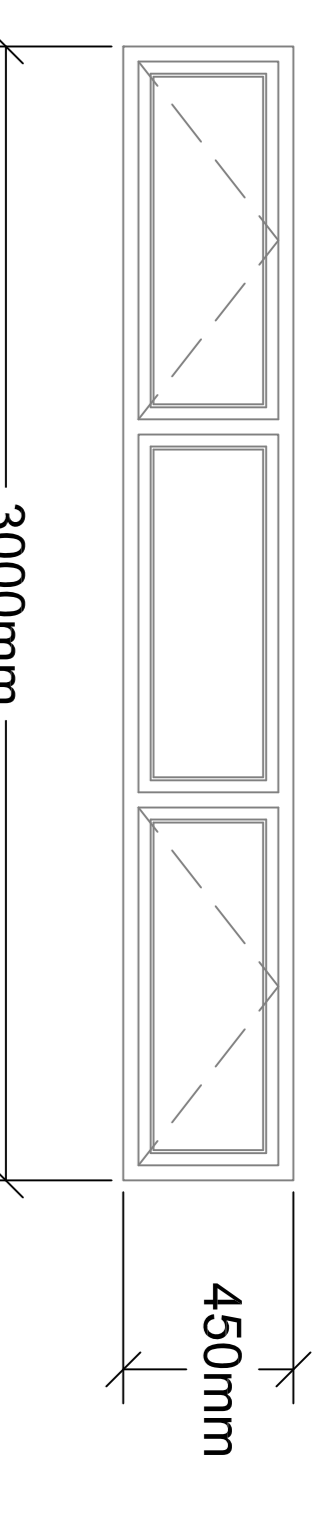

WG10

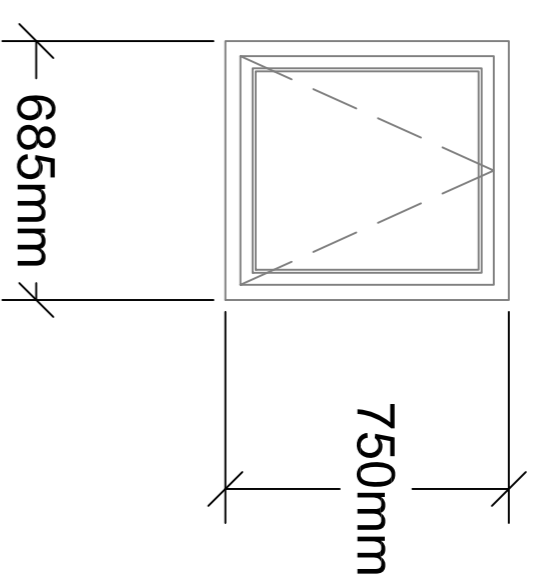

LG01 - Ventilation louvers

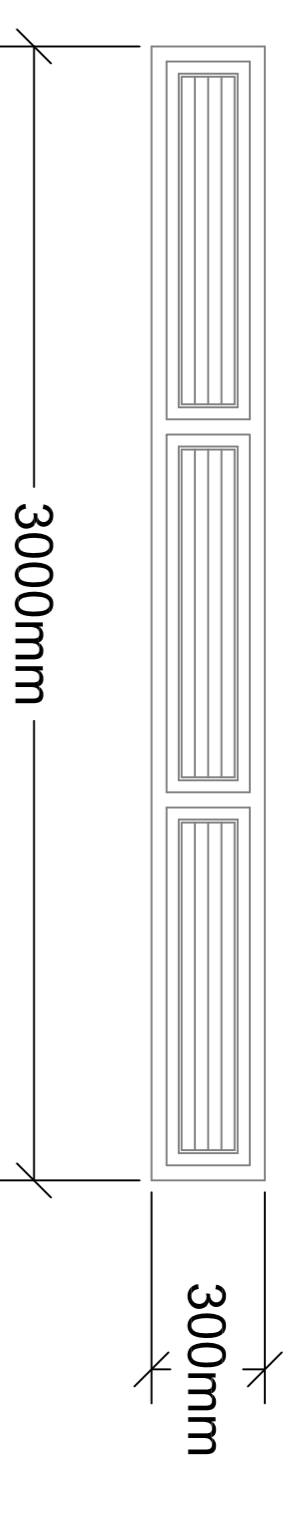

WB06 - Light well

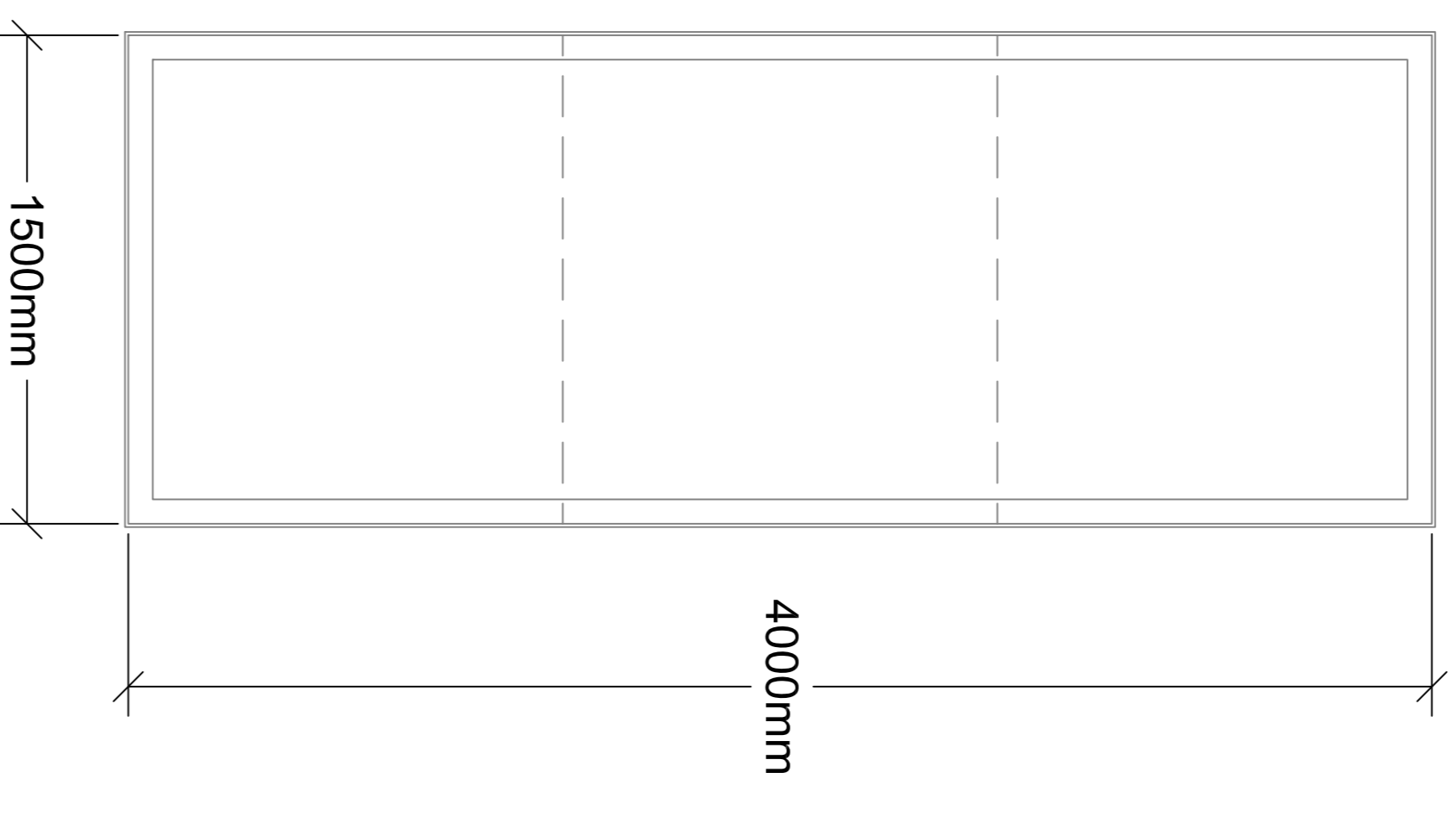

WG01

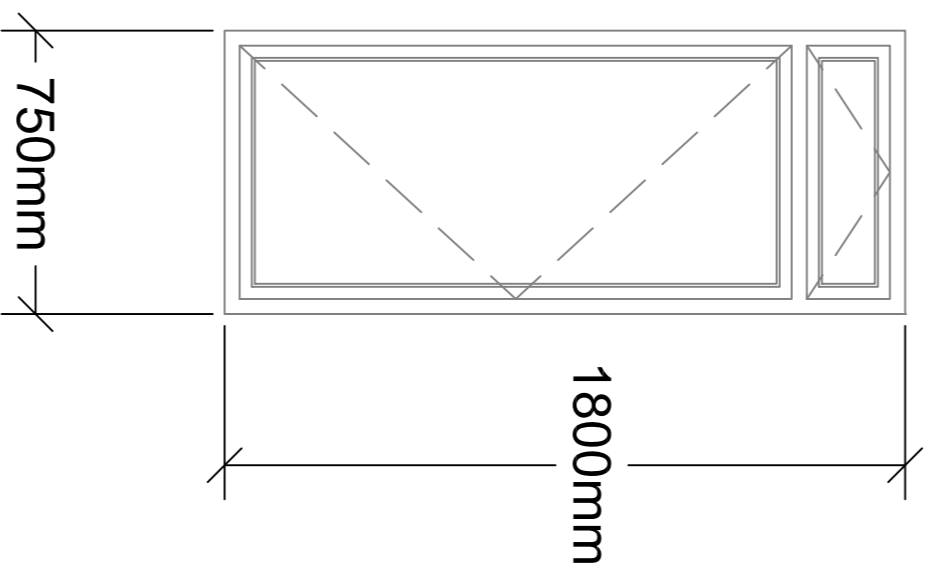

WG02

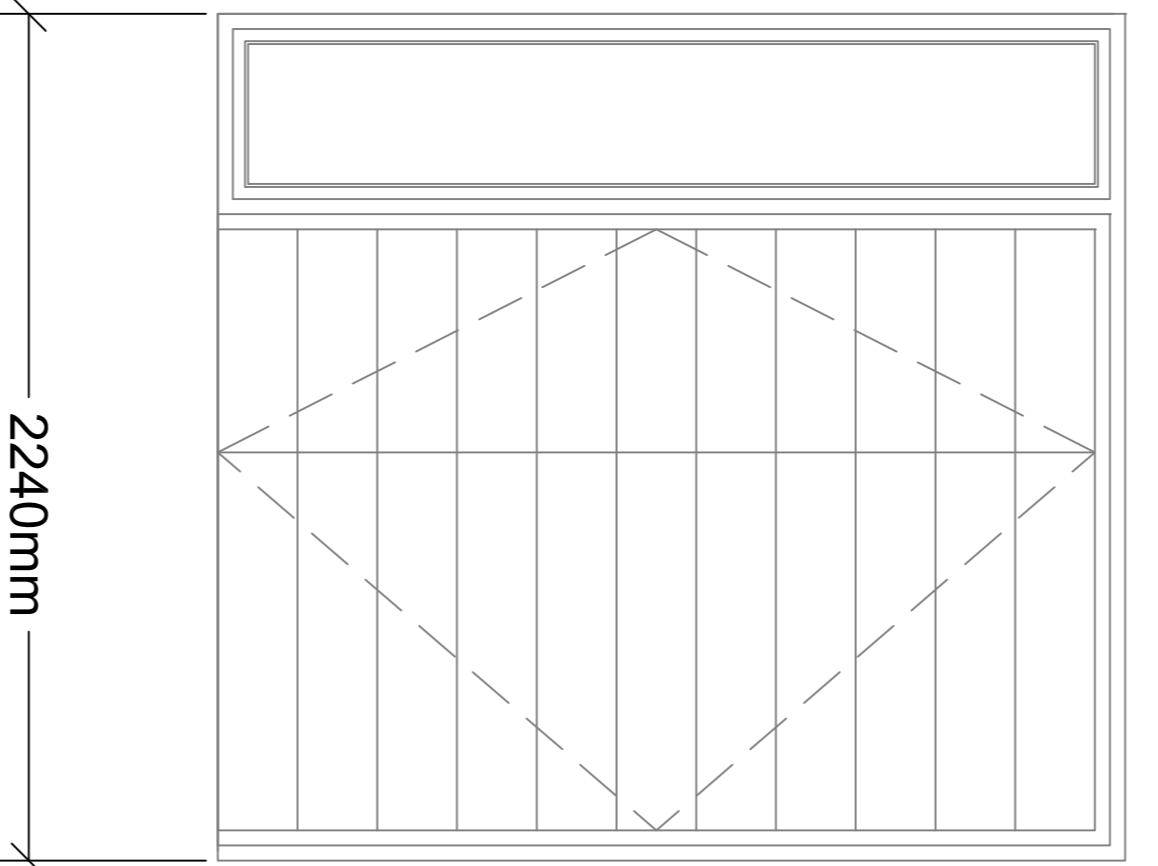

ED01

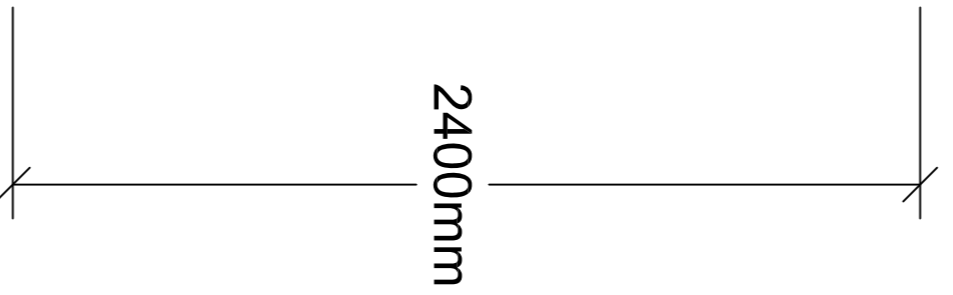

WG04



WG05 - Bi-fold doors

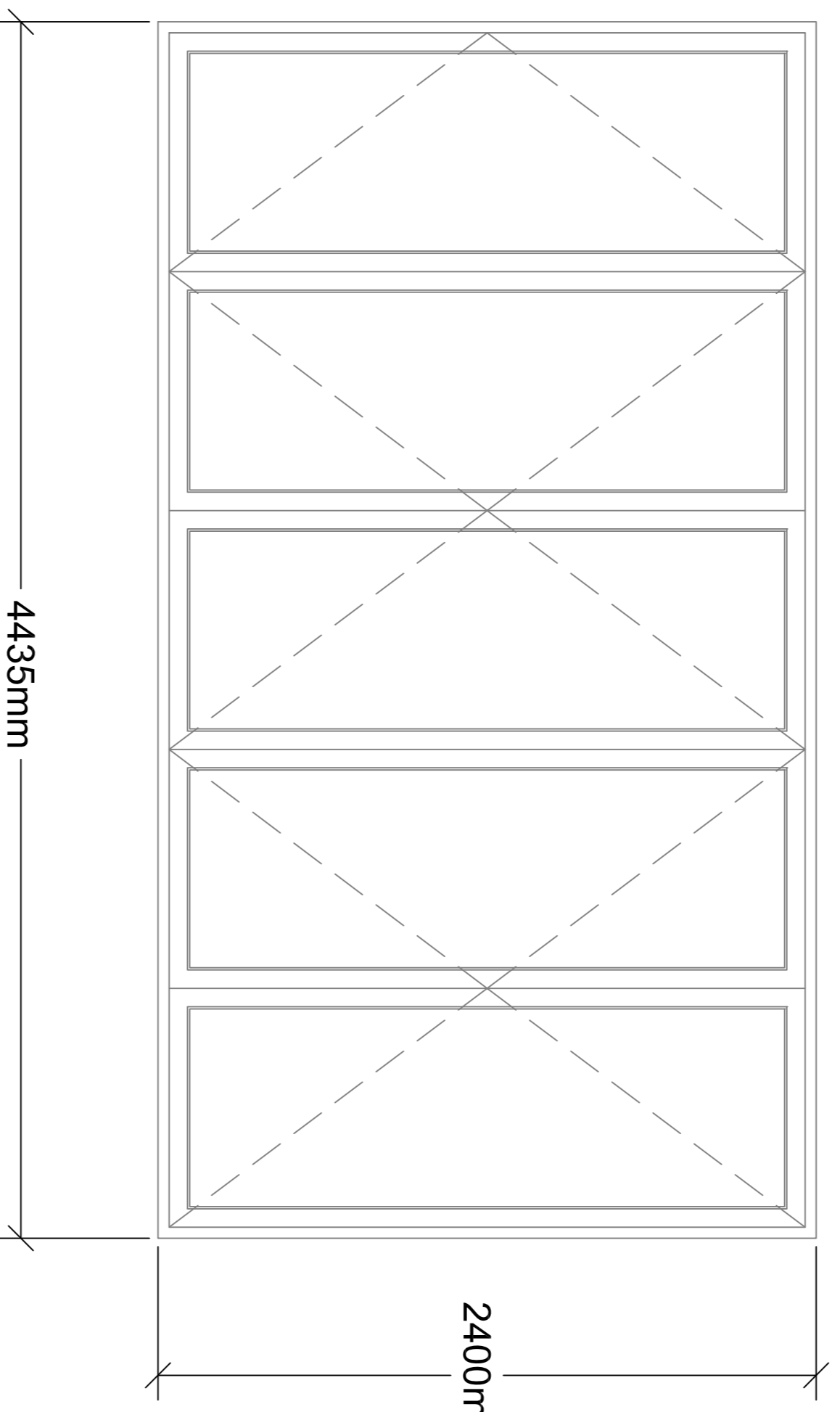

GD01 - Garage door

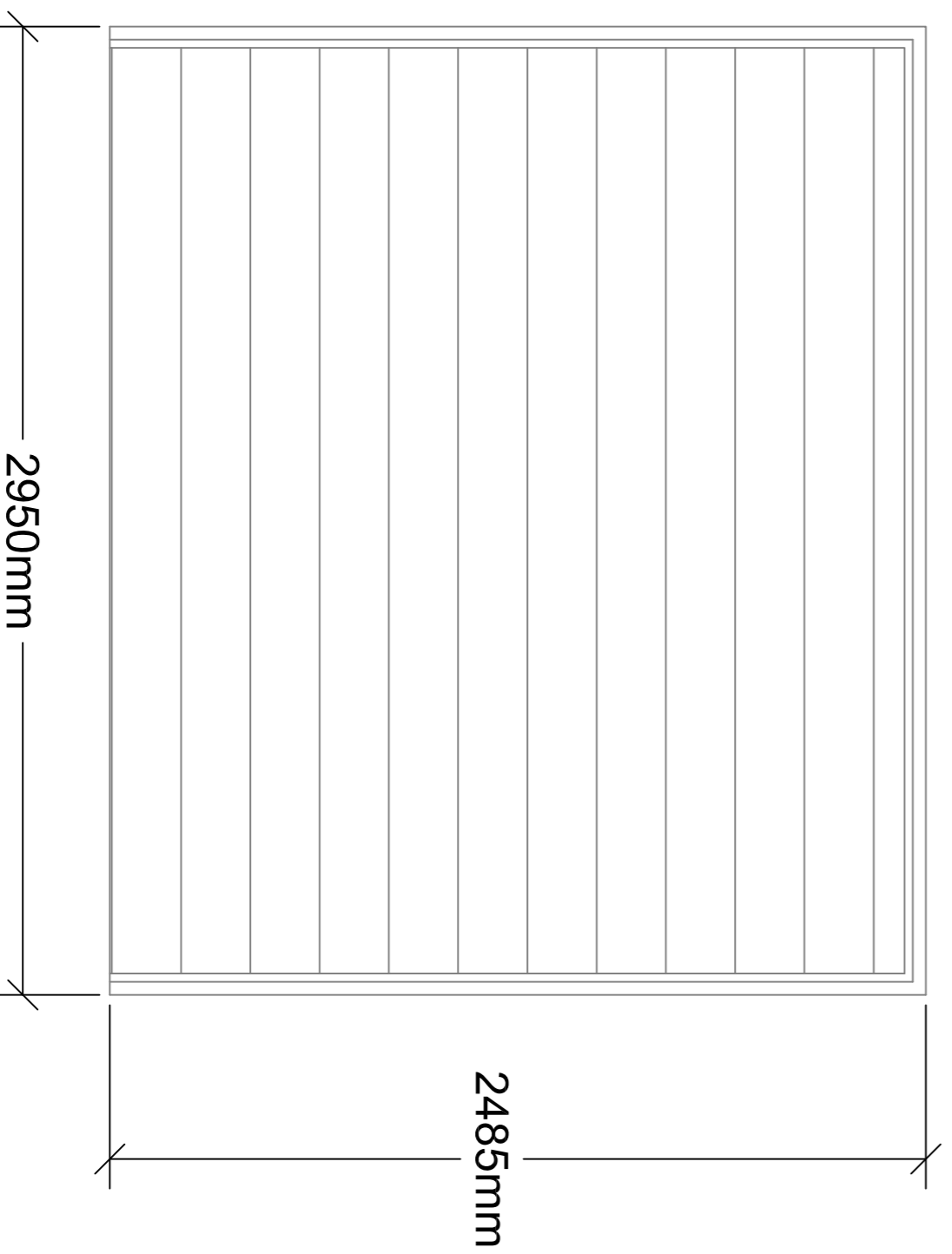

WB01

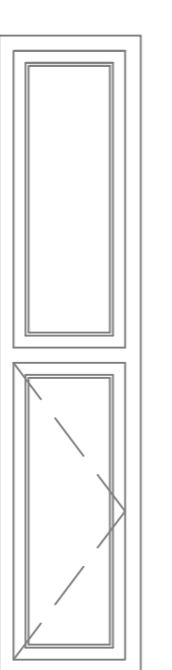

WB03



WB05 - Sliding doors

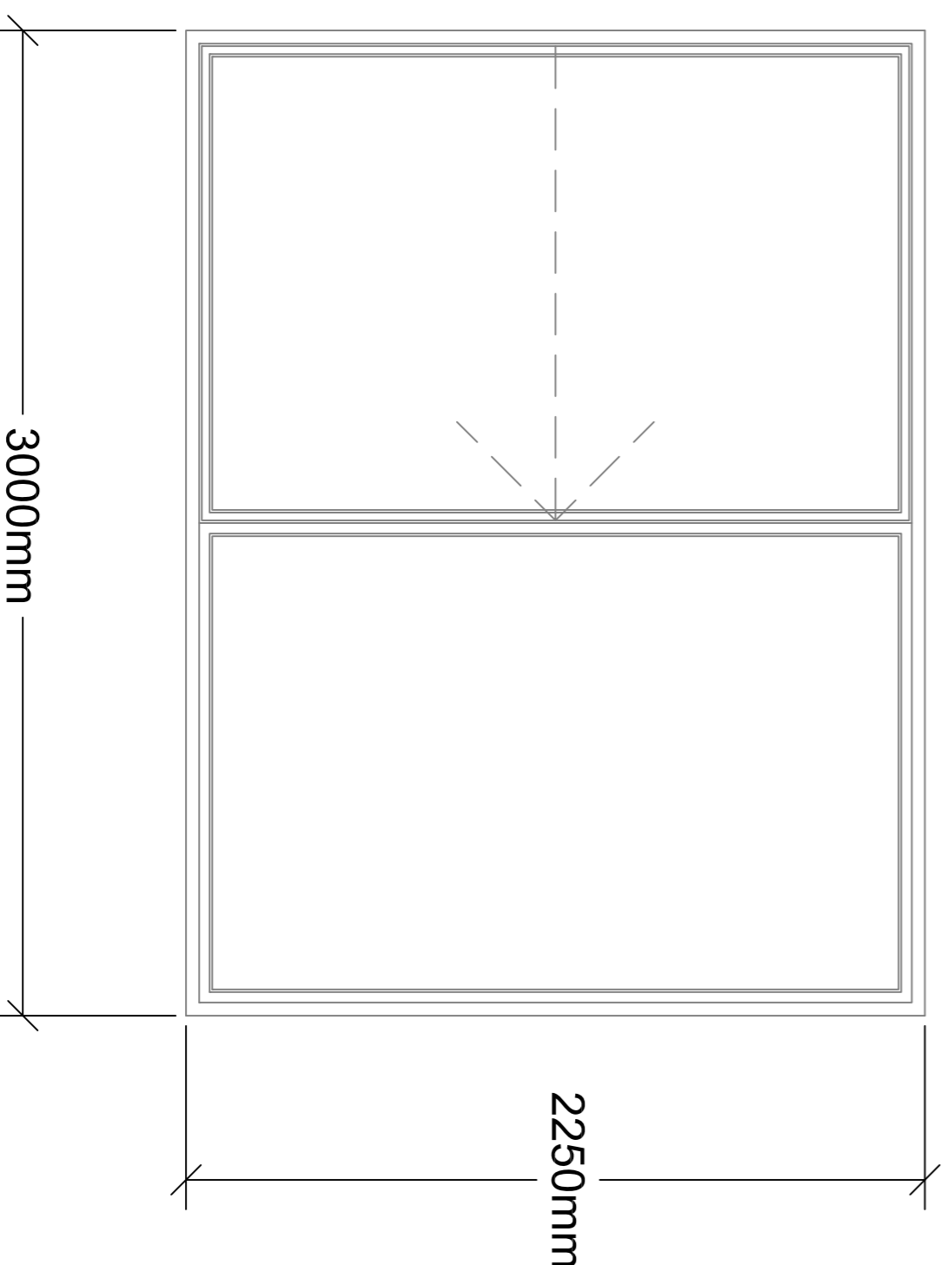

WB02

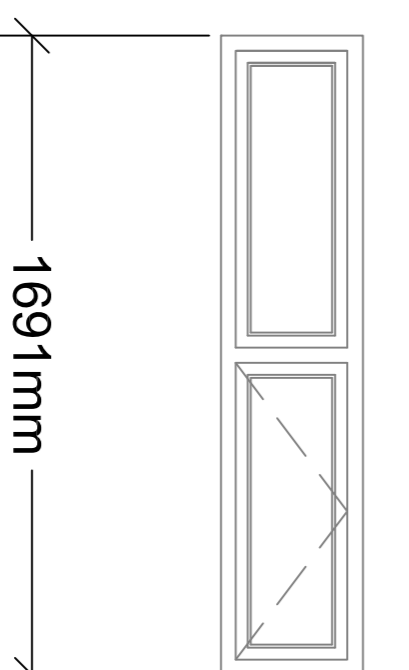

WB04

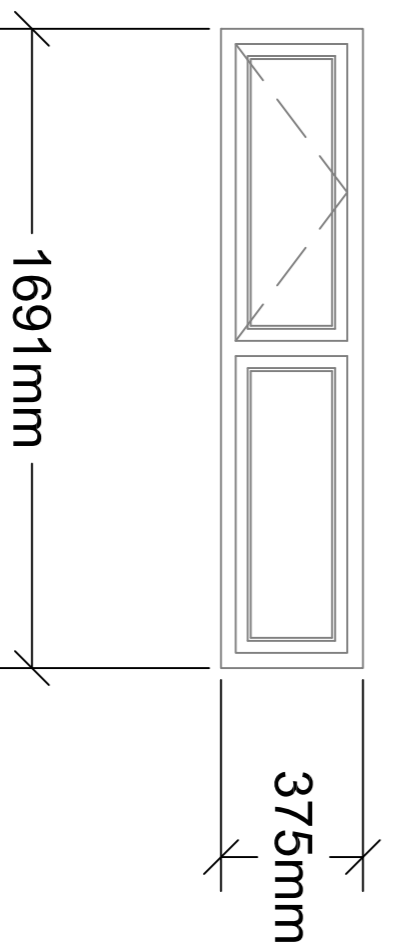

**General Specification**  
Thermally broken polyester powder coated aluminum frames.

**Sliding screens**  
Double glazed units comprising 6mm toughened Low E glass inner pane, 16mm Argon gas filled clear glass external pane to achieve centre pane U-value of 1.2 w/m<sup>2</sup>K.

**Windows**  
Double glazed units comprising 6mm toughened Low E glass inner pane, 16mm Argon gas filled clear glass external pane to achieve centre pane U-value of 1.2 w/m<sup>2</sup>K.

**Walk-on Lightwell**  
Horizontal walk-on flat roof glass skylight by Sunsquare Ltd tel 0845 236 3172  
Specialist subcontractor to design, supply & install fixed and sliding glass panels incorporating independent fall safety.

A	25/11/13	RGH	Renumbered with WB04 & WB05 added
B	04/04/13	RGH	E001/WG02/WG04/WG05/WG06 amended
C	19/06/14	RGH	General amendments
D	04/12/14	RGH	Louvers ref LG01 added
E	19/01/15	RGH	General amendments
F	21/09/15	RGH	Amended and issued for construction
G	17/12/15	RGH	WG05 & WG06 amended

**RGH** Frazer Gap Hitchin Road  
 Hitchin Herts SG4 7AX  
 Tel: +44 (0) 1462 790232  
 Email: info@rgh.co.uk

**Tykos Holdings Group**  
 New residential dwelling  
 Netherhall Gardens  
 NW3 5RN

12004	12004	A-020
Nov 2013	Nov 2013	A B C D E F G
1:20	A1	RH RH

**CONSTRUCTION**