

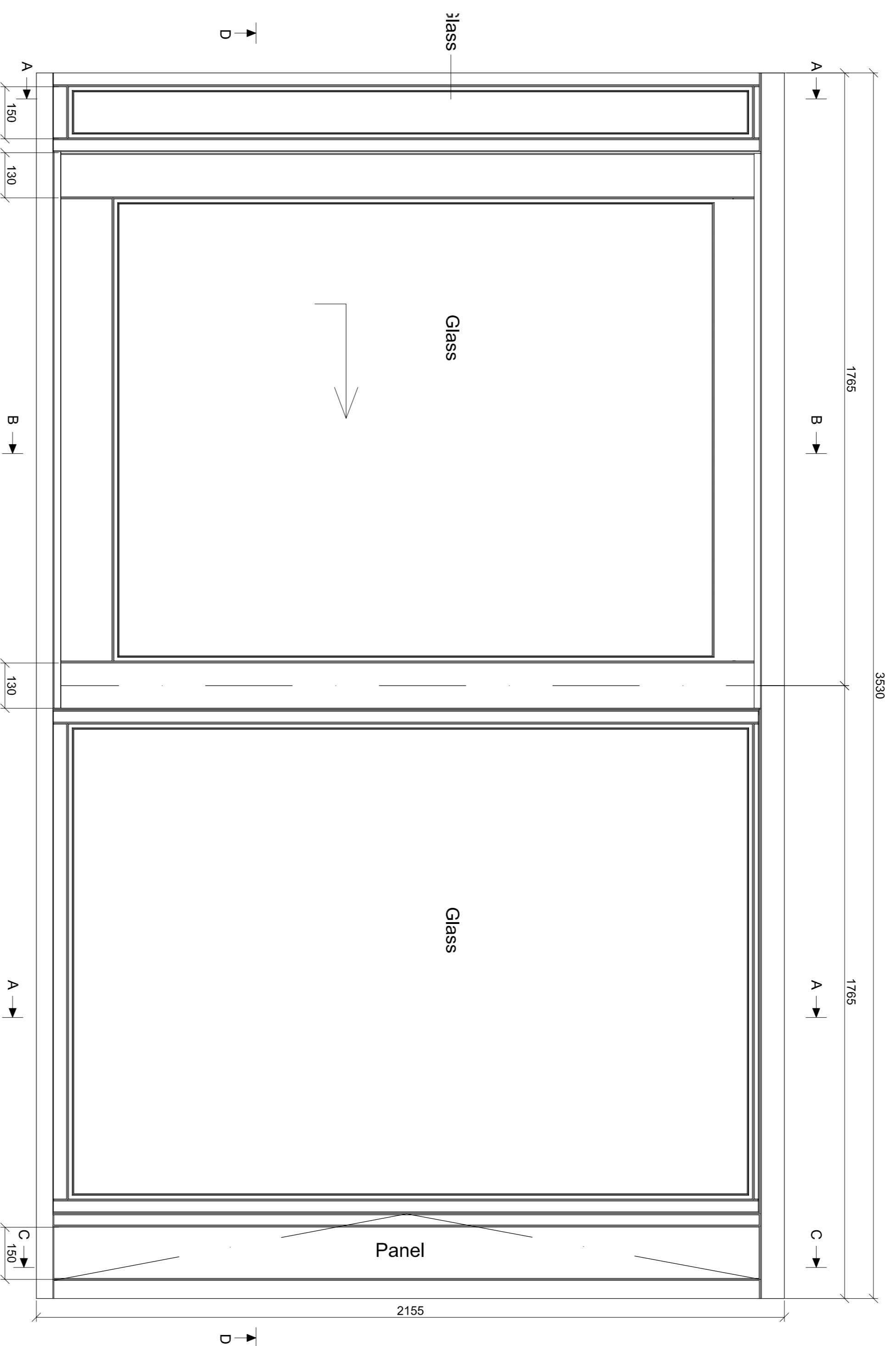

M - Top Floor

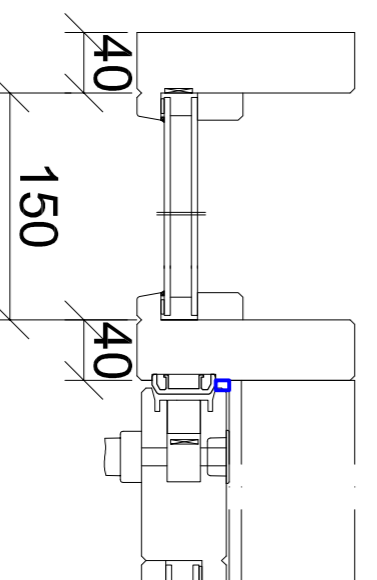

Proposed Type M - Rear bedroom Sliding doors.  
scale 1:10



Proposed Jamb Details  
scale 1:5

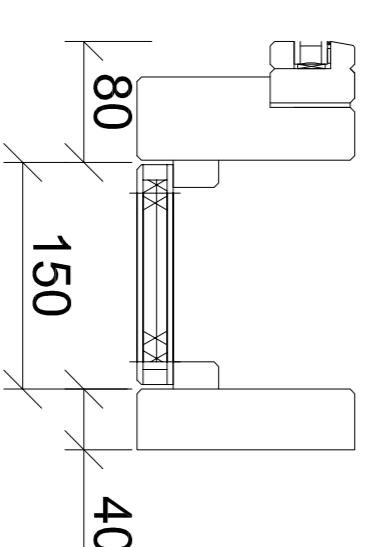
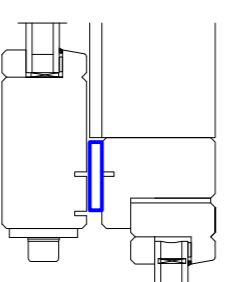

D-D

**NOTE**  
All 'Proposed' dimensions are for manufacturing purposes and therefore may differ slightly from the 'Existing' dimensions.

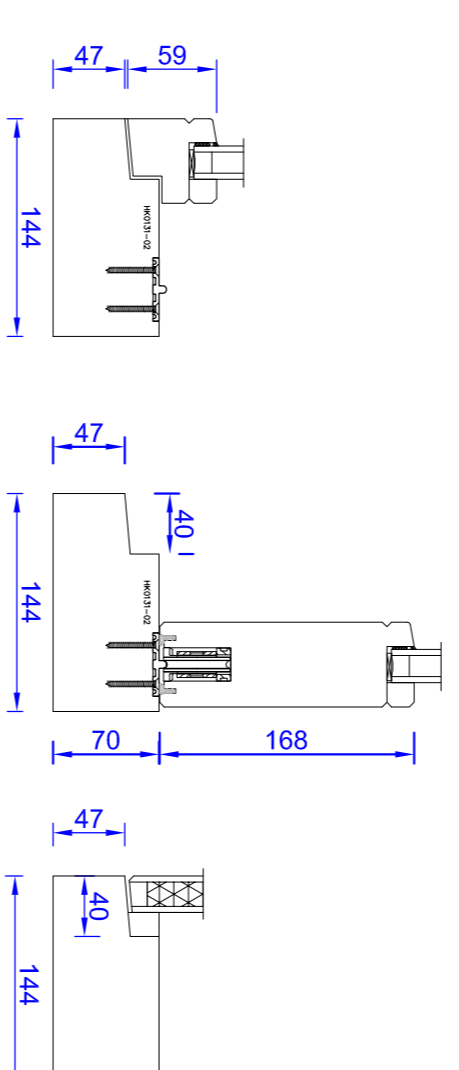
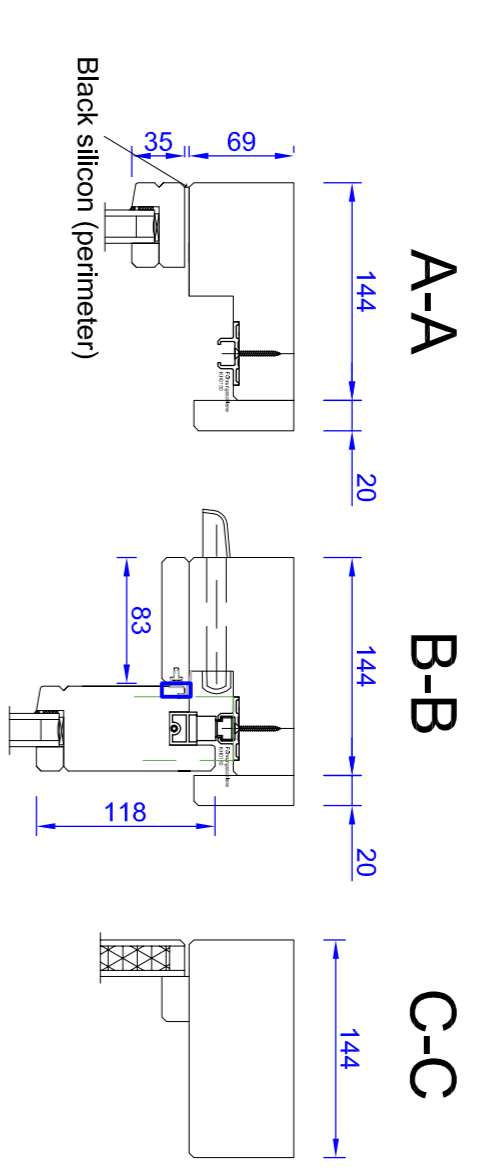

Proposed Head & Sill Details  
scale 1:5

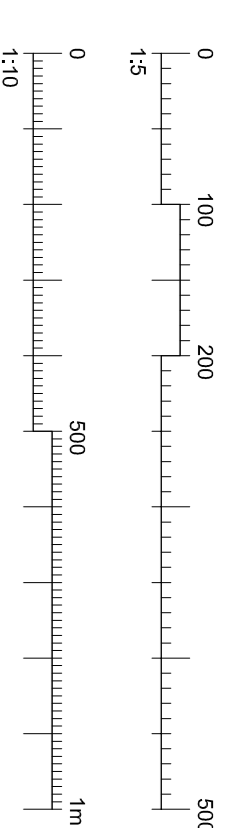

The contractor is responsible to ensure that no products are used which do not comply with relevant British and/or European Standards and/or Codes of Practice, Current Regulations, and/or construction to the satisfaction of health and safety or to the standard of the work or not in accordance with good building practice.  
The contractor is responsible for checking dimensions, tolerance, length and performance. Any discrepancy to be notified to Bailey Garner LLP and rectified before proceeding with the work. Where an item is covered by drawings to different scales, the larger scale drawings is to be used.  
Do not scale drawings. Figure dimensions to be used in all cases.  
This drawing and the copyright and patent therein are the property of Bailey Garner LLP and may not be used or reproduced without consent or attribution.

REVISION	DATE
0	C

**A1**

**CLIENT**  
Keenpoint Regeneration (Apollo) Ltd

**PROJECT**  
Mansfield Road External Upgrades

**ADDRESS**  
Apollo Site Office  
Kiln Place  
Lamble Street, NW5 4AB

**TITLE**  
Proposed Window Type M  
Proposed or Existing  
Planning

**DATE**  
20/11/15

**SCALE**  
1:10

**DRAWING NO.**  
27241

**REVISION**  
PL 25

**BAILEY · GARNER**

144-148 ELMHILL  
LONDON SE8 3DT  
T: 020 8294 1000  
E: graham@bailey-garner.co.uk