

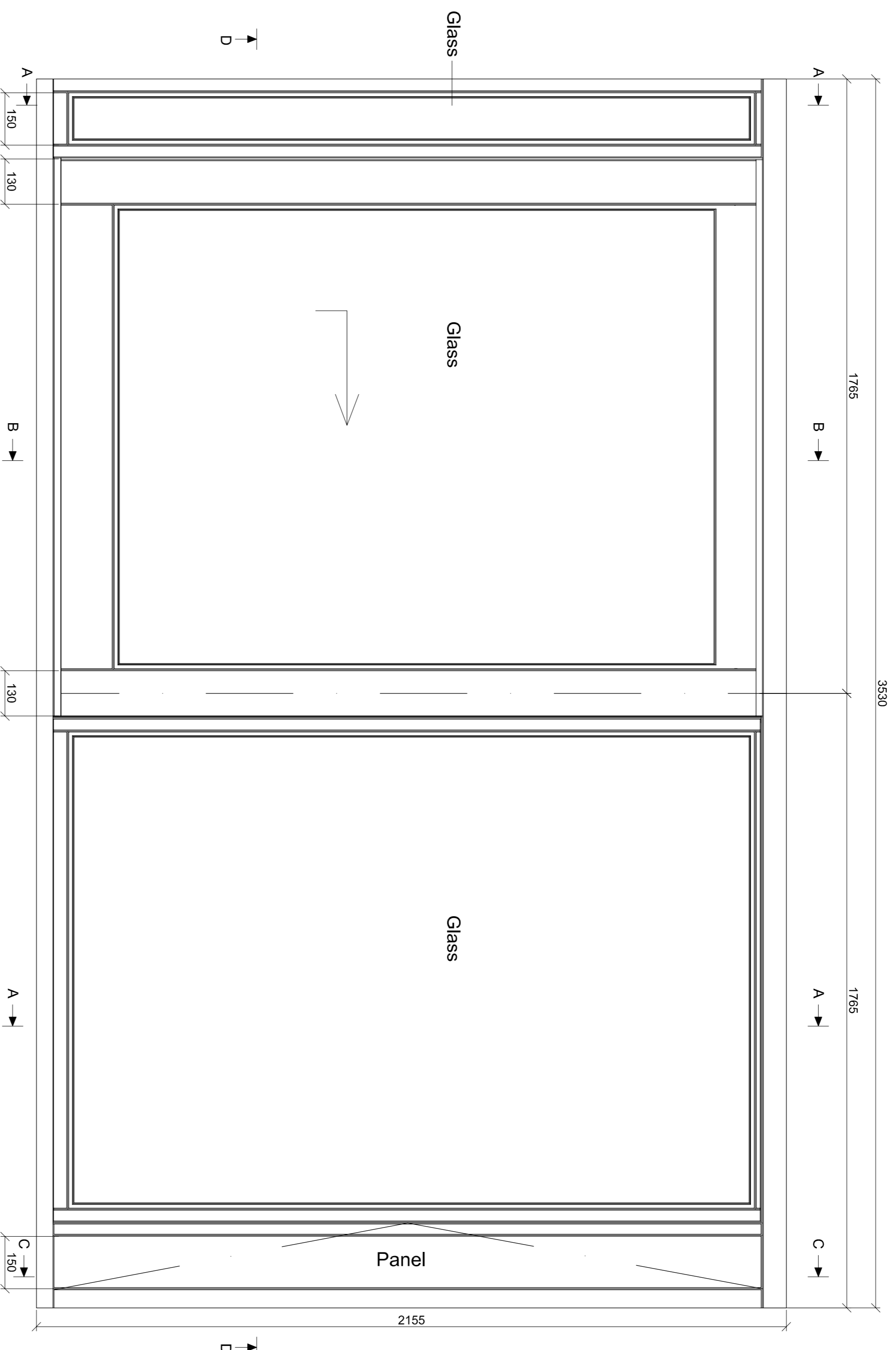

M - Top Floor

NOTE
All 'Proposed' dimensions are for manufacturing purposes and therefore may differ slightly from the 'Existing' dimensions.

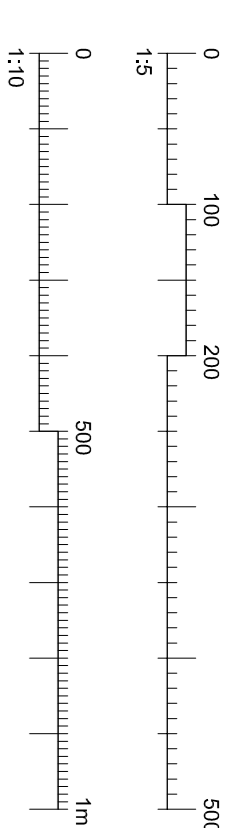

Existing Type M - Rear bedroom Sliding doors.
scale 1:10

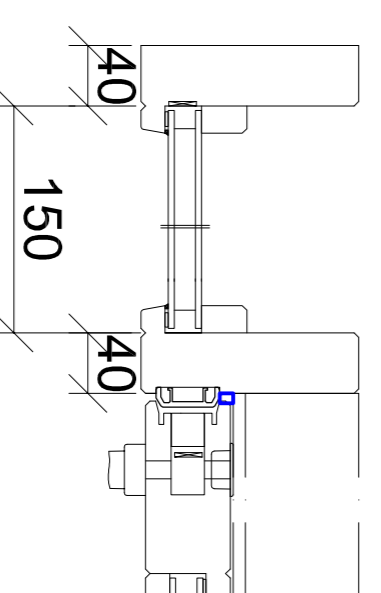

Existing Jamb Details
scale 1:5

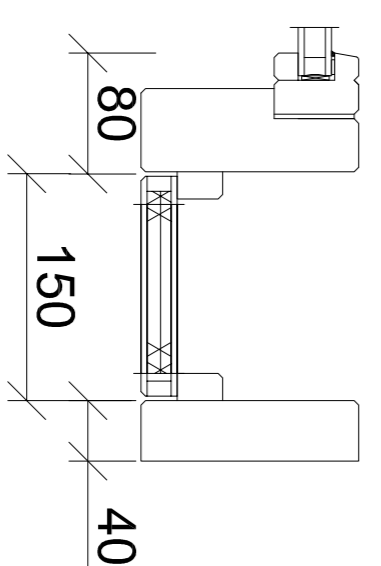
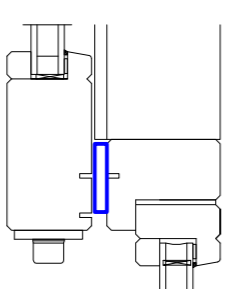

D-D

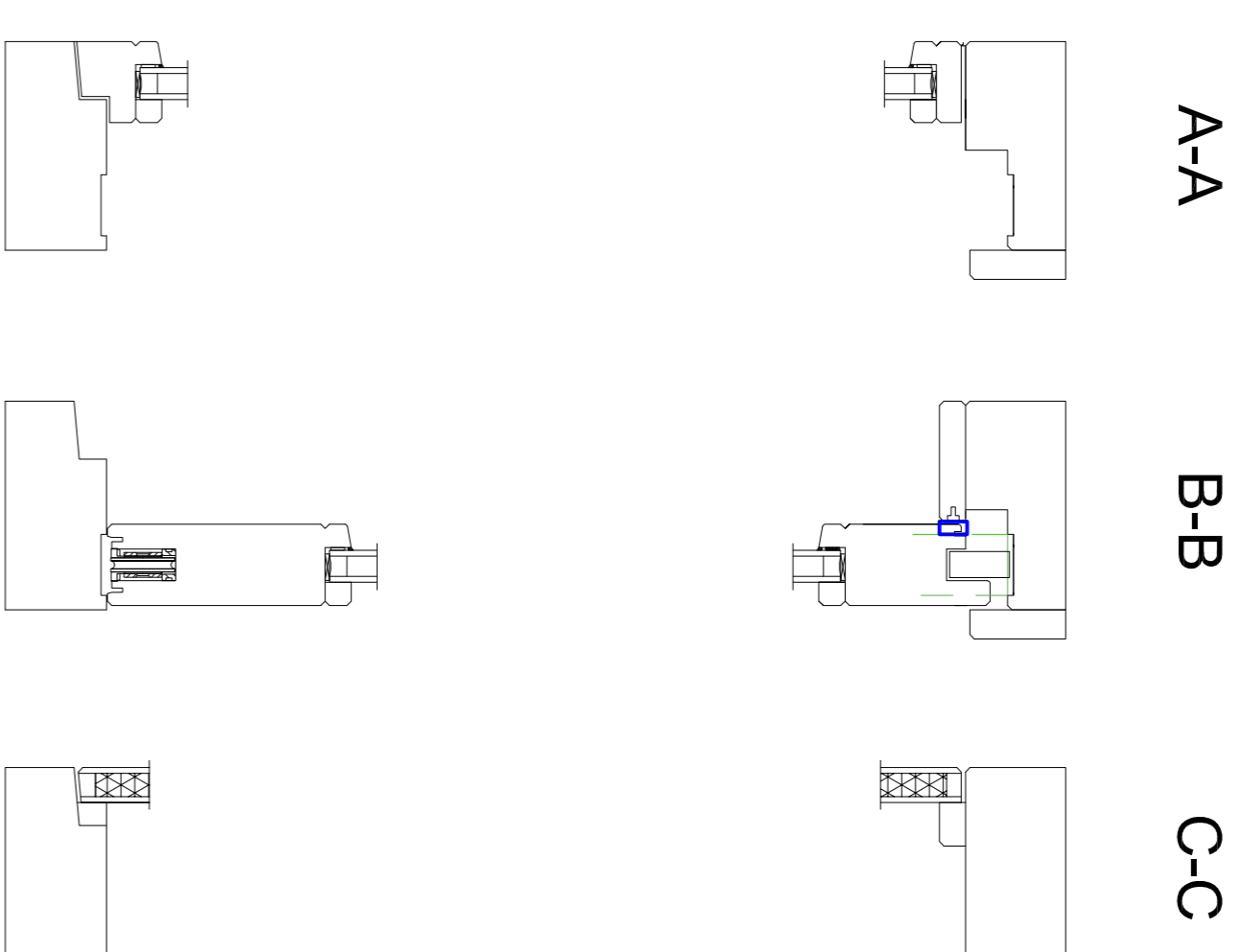

Existing Head & Sill Details
scale 1:5

The contractor is responsible to ensure that no products are to be installed that do not comply with relevant British and/or European Standards and/or Codes of Practice, Current Regulations, and/or construction to the satisfaction of health and safety or to the quality of the work or not in accordance with good building practice.
The contractor is responsible for checking dimensions, tolerance, length and performance. Any discrepancy is to be notified to Bailey Garner LLP and rectified before proceeding with the work. Where an item is covered by drawings to different scales, the larger scale drawings is to be used.
Do not scale drawings. Figure dimensions to be used in all cases.
This drawing and the copyright and patent therein are the property of Bailey Garner LLP and may not be used or reproduced without consent or attribution.

REVISION	DATE
0	C

A1

CLIENT
Keenpoint Regeneration (Apollo) Ltd

PROJECT
Mansfield Road External Upgrades

ADDRESS
Apollo Site Office
Kiln Place
Lamble Street, NW5 4AB

TITLE
Existing Window Type M
Proposed or Rebuilt
Planning

DATE
20/11/15

SCALE
1:10

NO. AND
27241

REVISION
PL 24

BAILEY · GARNER

144-146 ELMHILL
LONDON SE8 5JY
T: 020 8284 1000
E: graham@bailey-garner.co.uk