

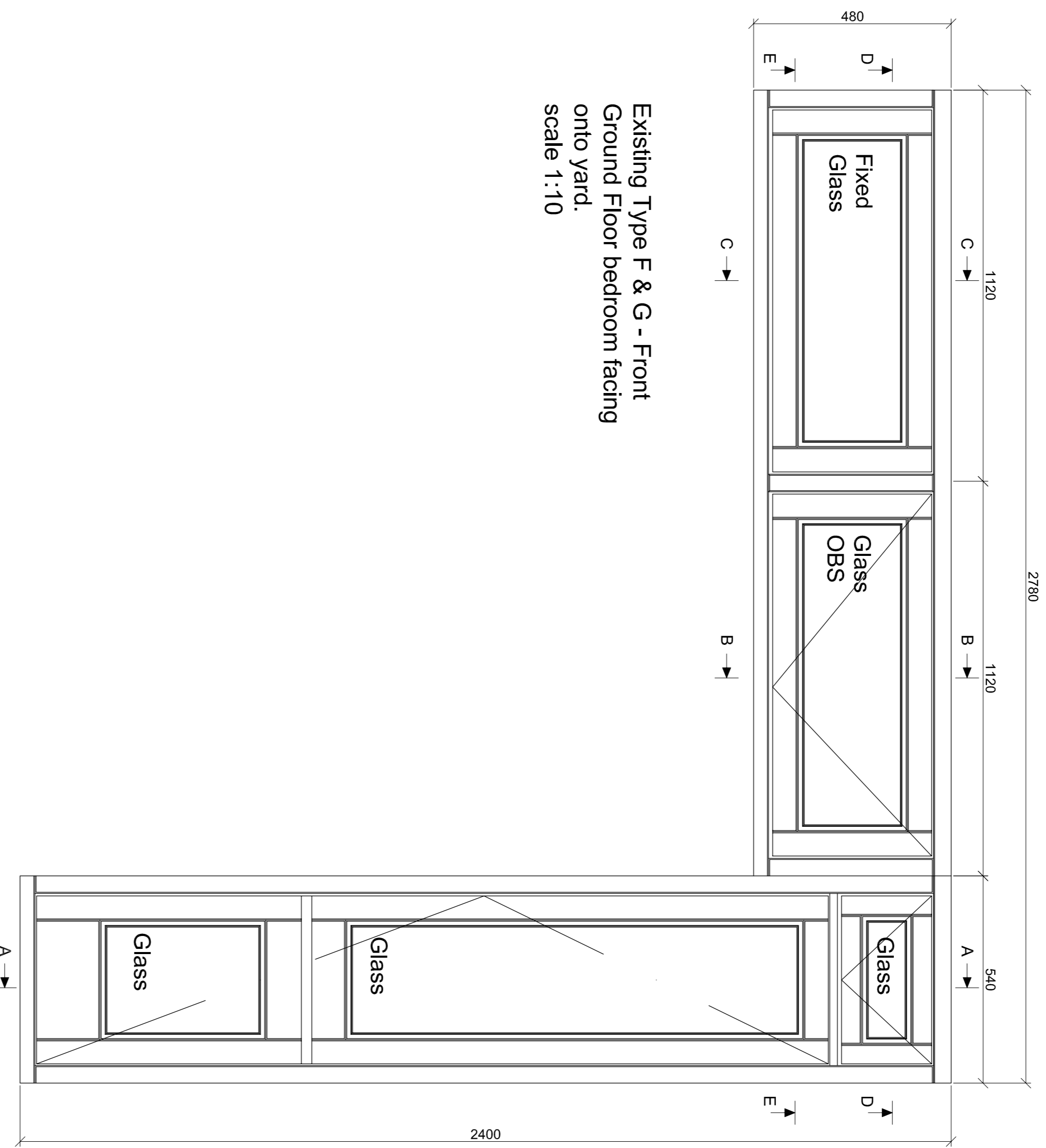

G

F

NOTE
All 'Proposed' dimensions are for manufacturing purposes and therefore may differ slightly from the 'Existing' dimensions.

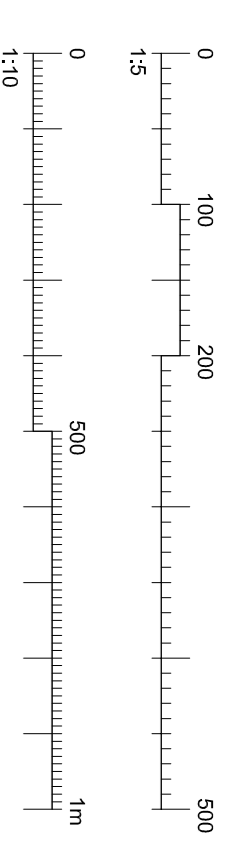

Existing Type F & G - Front
Ground Floor bedroom facing
onto yard.
scale 1:10

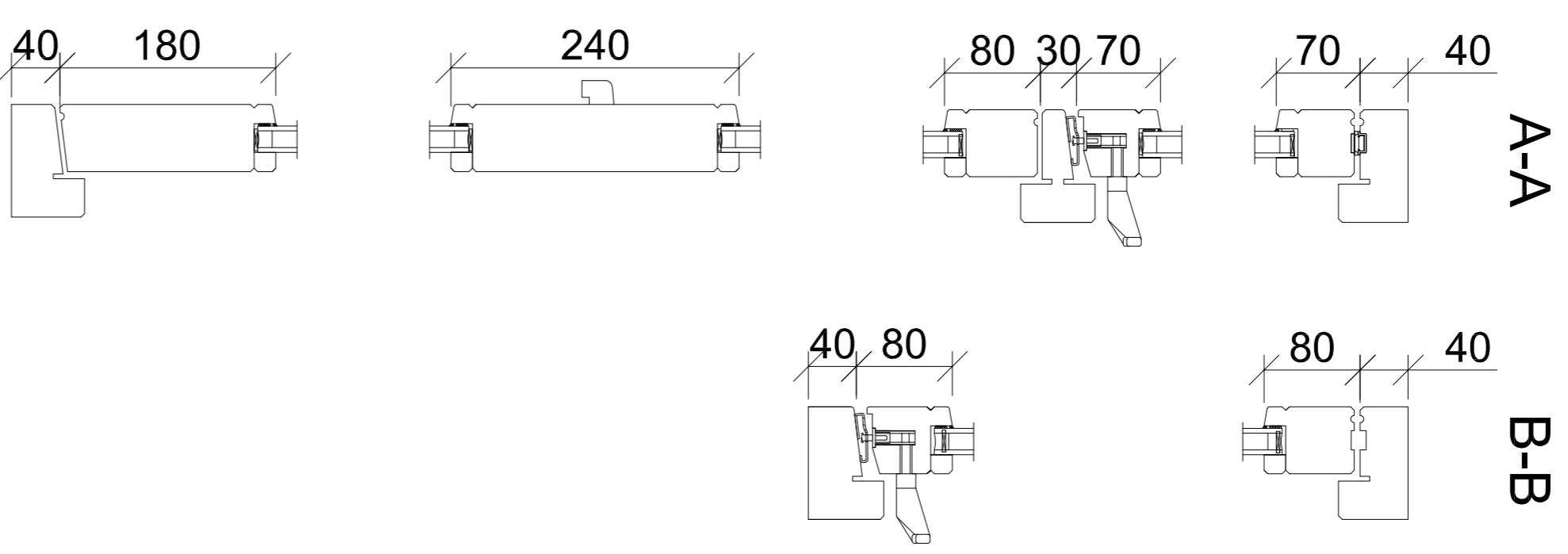

Existing Head & Cill Details
scale 1:5

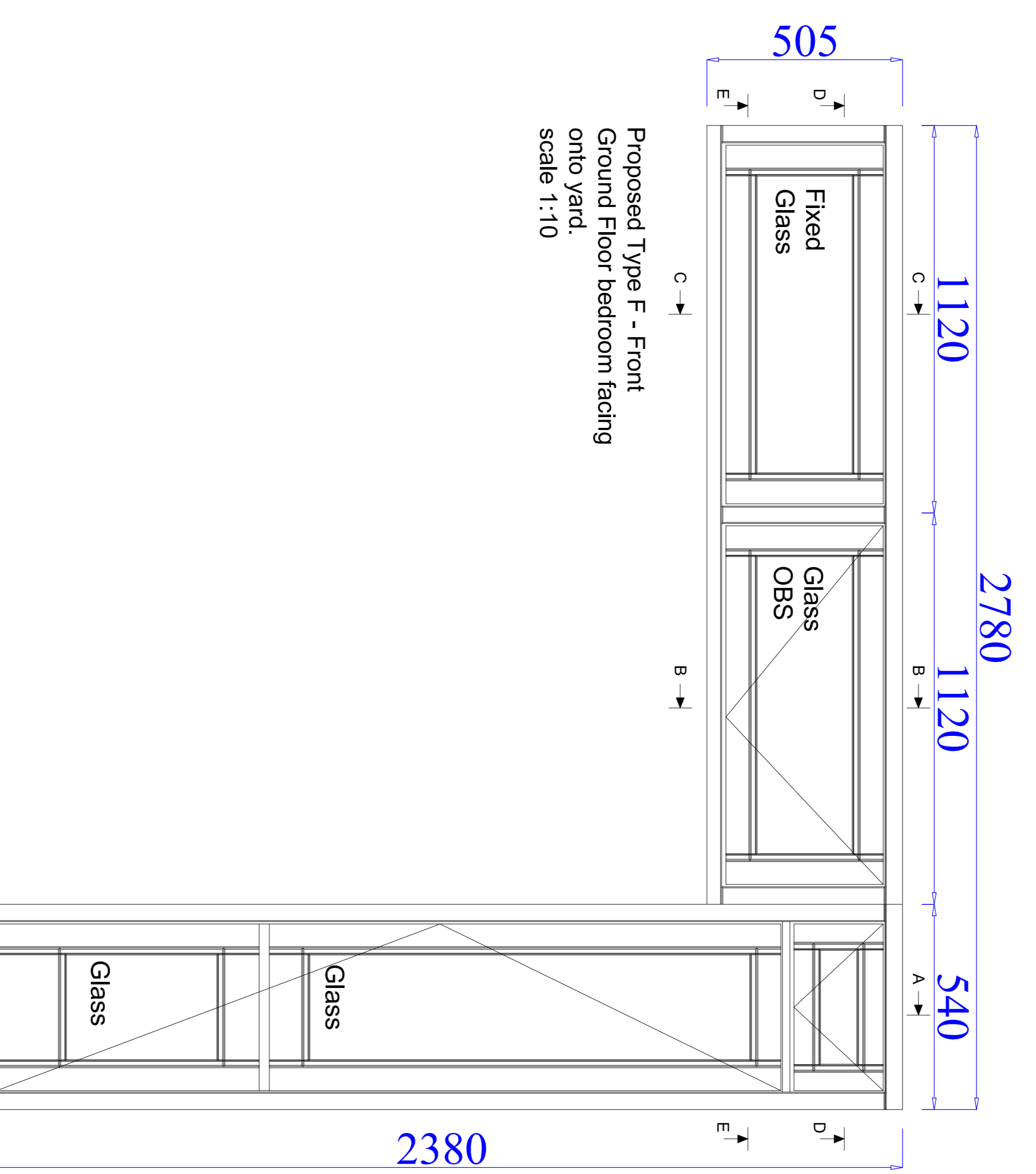

Proposed Type F - Front
Ground Floor bedroom facing
onto yard.
scale 1:10

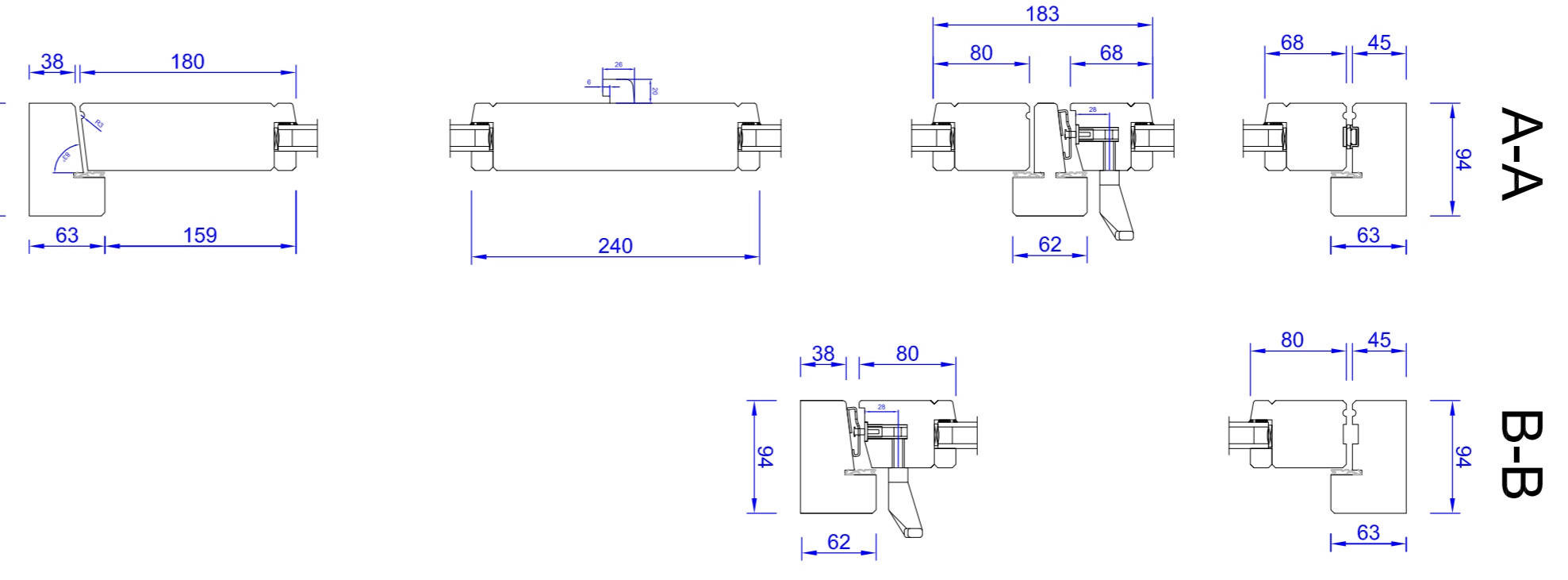

Proposed Head & Cill Details
scale 1:5

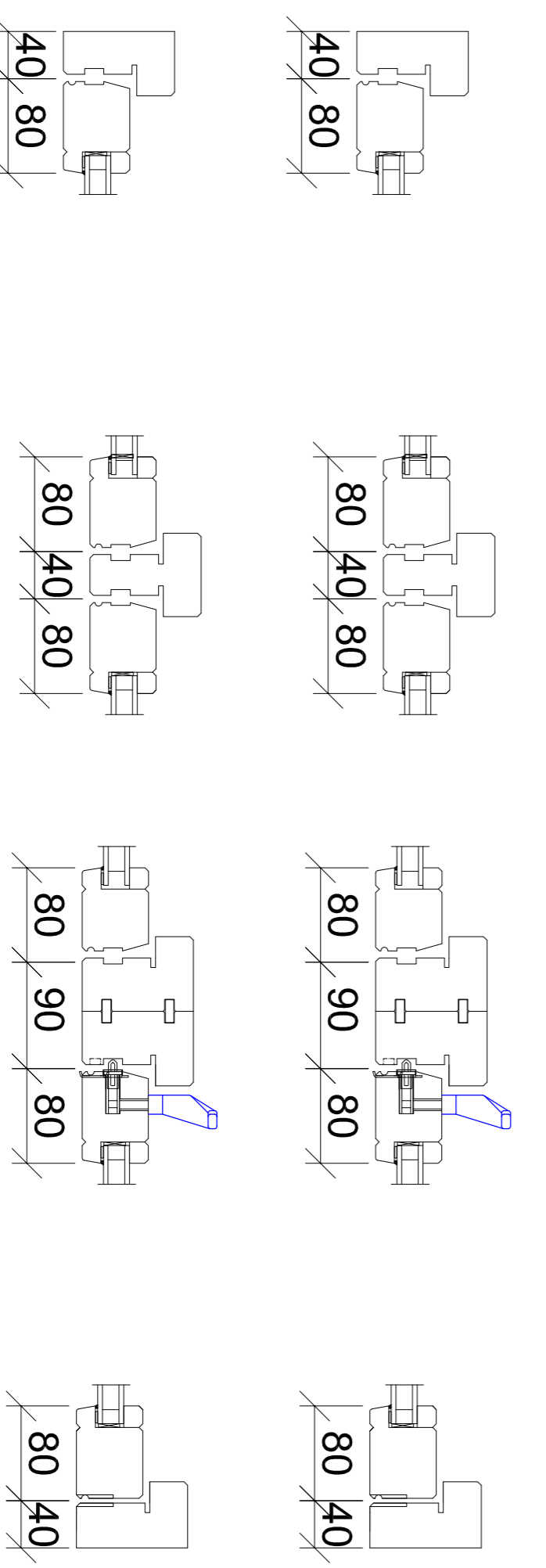

Existing Jamb Details
scale 1:5

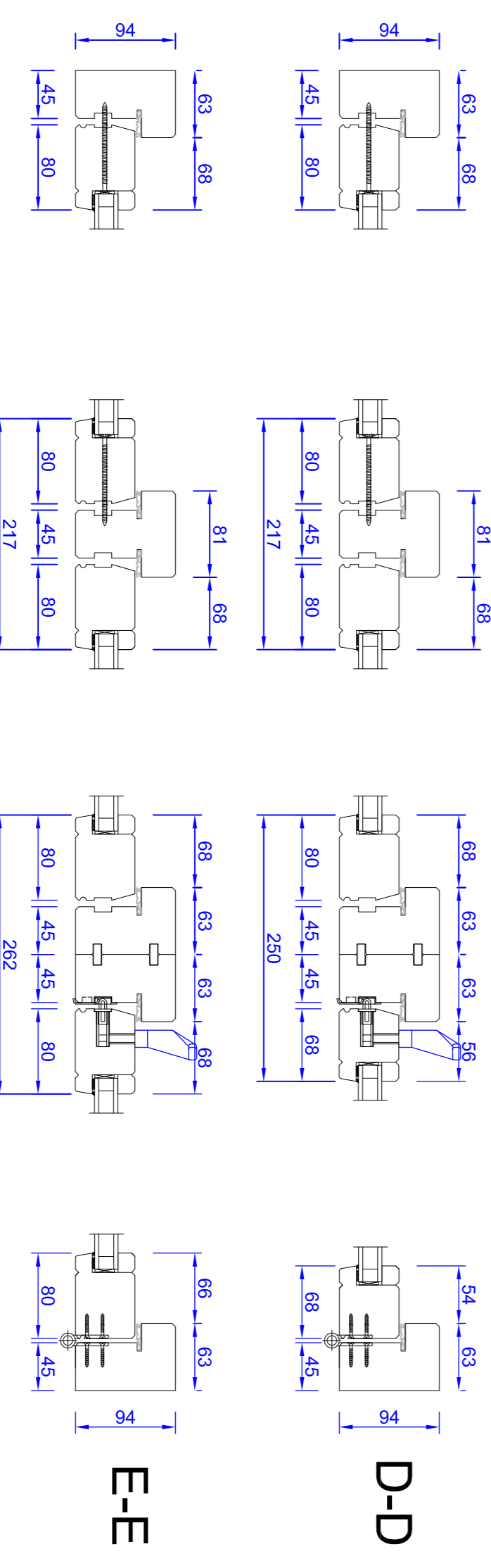

Proposed Jamb Details
scale 1:5

This contractor is responsible to ensure that no products are to be installed that do not comply with relevant British and/or European Standards and/or Codes of Practice. Client Responsibilities, and/or construction to be determined by health and safety for the duration of the work or in accordance with good building practice.

The proposed work is a replacement of existing windows, doors, and external cladding. The drawings are for information only and are not to be used for construction. The drawings are to be used in conjunction with the relevant Building Regulations and other applicable legislation. The drawings are to be used in conjunction with the relevant Building Regulations and other applicable legislation. The drawings are to be used in conjunction with the relevant Building Regulations and other applicable legislation.

Do not scale drawings. Figure dimensions to be used for all cases. This drawing and the copyright and patent therein are the property of Bailey Garner Ltd and may not be used or reproduced without consent or attribution.

A1

CLIENT: Keepmoat Regeneration (Apollio) Ltd
PROJECT: Mansfield Road External Upgrades

ADDRESS: Apollio Site Office
Kiln Place
Lamble Street, NW15 4AB

TITLE: Existing & Proposed Window Type F & G
PURPOSE: For Planning

DATE: 30/11/15
REVISION: PL 21

BAILLY · GARNER
144-146 ELMHILL
LONDON SE8 5DT
T: 020 8284 1000
E: g.garnier@bailllygarner.co.uk
W: www.bailllygarner.co.uk