

ADDITIONAL NOTES:
50mm CONSTRUCTION

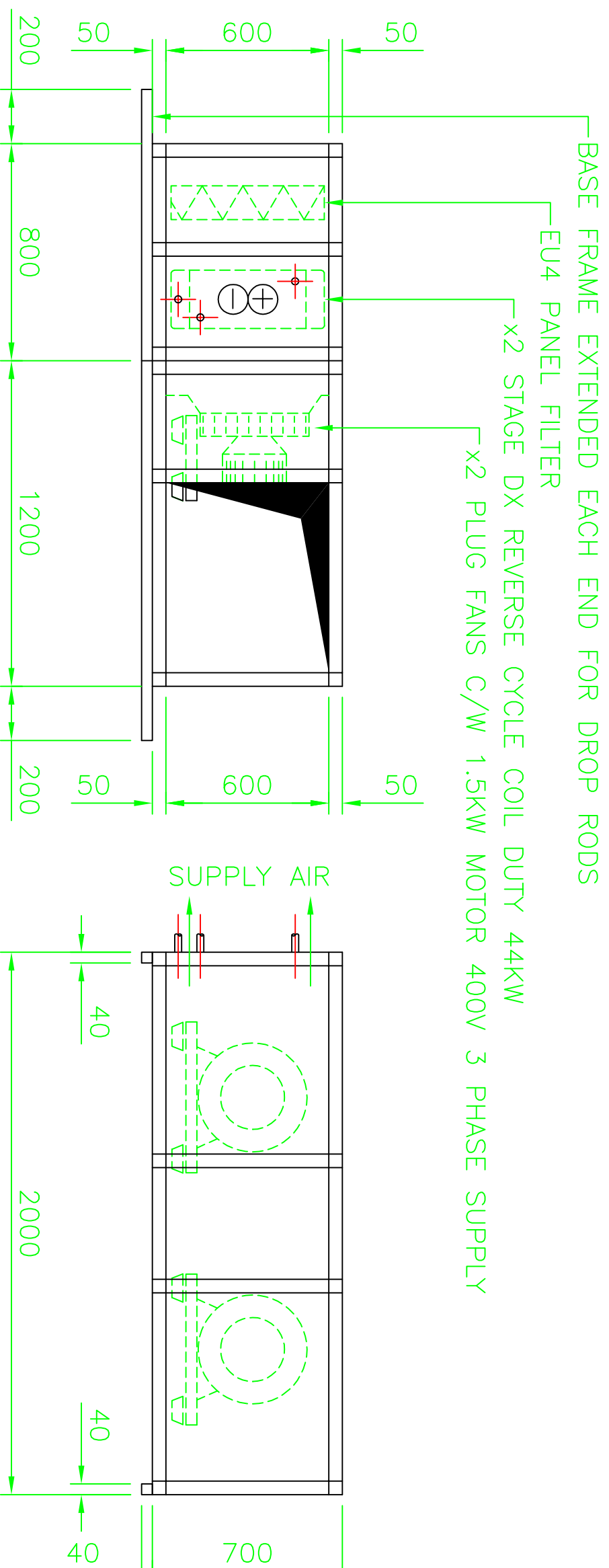

NOTE:
Keep Drop Rods (If Any) And
Pipework etc. Clear Of Access
And Withdrawal Positions.

Unit Double Skinned
Finish:

Colour: GOOSEWING GREY

A: Allow 2200mm For Withdrawal Of
Filters, Fan And Motor.

B: Allow 2200mm For Withdrawal Of
Coils etc.

Approx. Weight: 480 kg.

Unit Shipped In TWO SECTION(S)

AIRCRAFT AIR HANDLING

Unit 20, Moorfields Industrial Estate
Cotes Heath, Stafford, ST21 6QY
Tel: (01782) 791545/791623
Fax: (01782) 791283

Job Title: CAMBRIDGE

Job No: 15074 ADVANCED 2000 LTD

Original Drawing Date: 26.02.15.

Issue & Date: B, 05.03.15.

Drawing No: CD6136

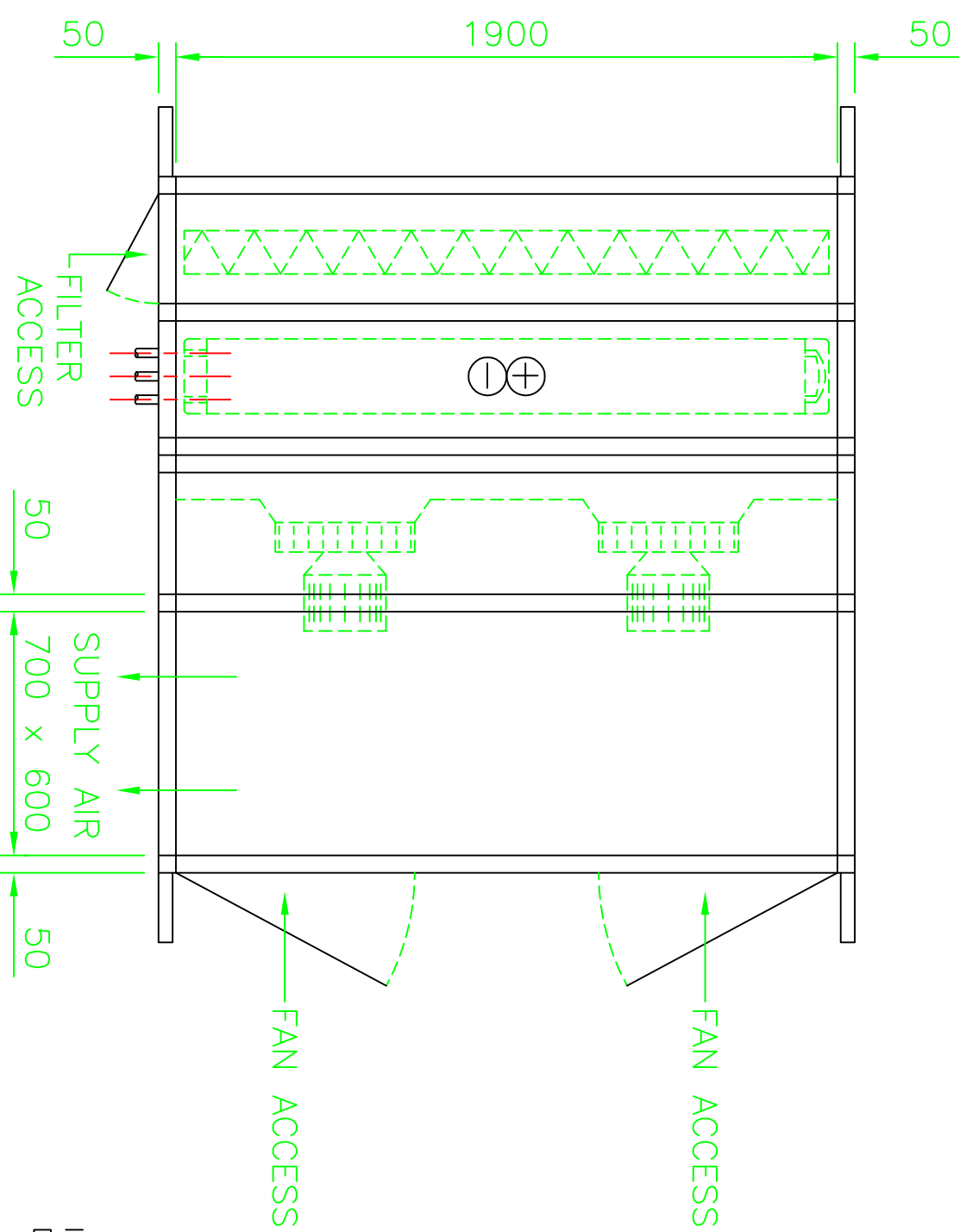

INTERNAL SUPPLY AHU
DESIGN AIR VOLUME: 2.4m³/s @ 400 EX PA