

NOTES: -

Contractor to check all dimensions on site prior to fabrication and inform the Architect of any discrepancies.

Drawing to be read in conjunction with drawing nos. 506MP4/DD008, 010 - 012.

- ① Principal oak column to New Court Link structure, to be rebated and beaded, as detailed drawing. Column to be 100 x 82mm over the full-height of the Ground Floor.
- ② Column and casement window frame to have a anti-capillary groove cut into both surfaces.
- ③ H/w timber casement window frames fabricated from Sapelle, rebated and moulded as illustrated on this detailed drawing. Casement windows to be curved in profile, to follow the curved Ground Floor Plan of the New Court Link.
- ④ 4mm curved yellow glass (to match the colour of the existing historic pale yellow glass used elsewhere in the Museum). Glass to be sprung and putted in position. All panes of glass to be fitted with safety film over the internal surface.
- ⑤ H/w timber glazing bars fabricated from Sapelle (curved on plan) rebated and moulded as illustrated on this detailed drawing.
- ⑥ PVC seal, fixed in machined groove in rebate.

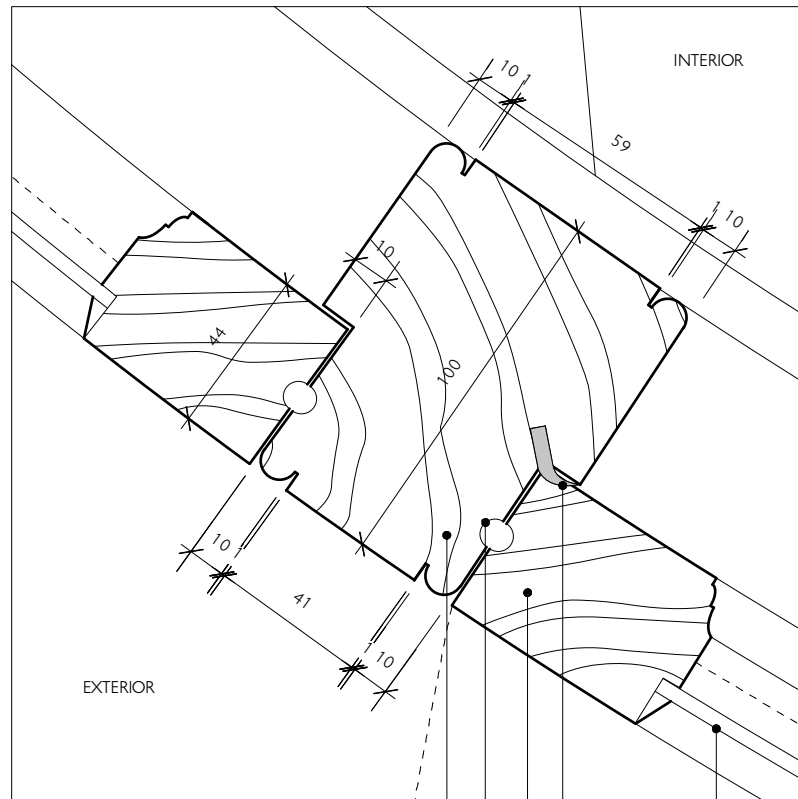

WINDOW DETAIL PLAN AT COLUMN (1:2)

- ①
- ②
- ③
- ⑥
- ④

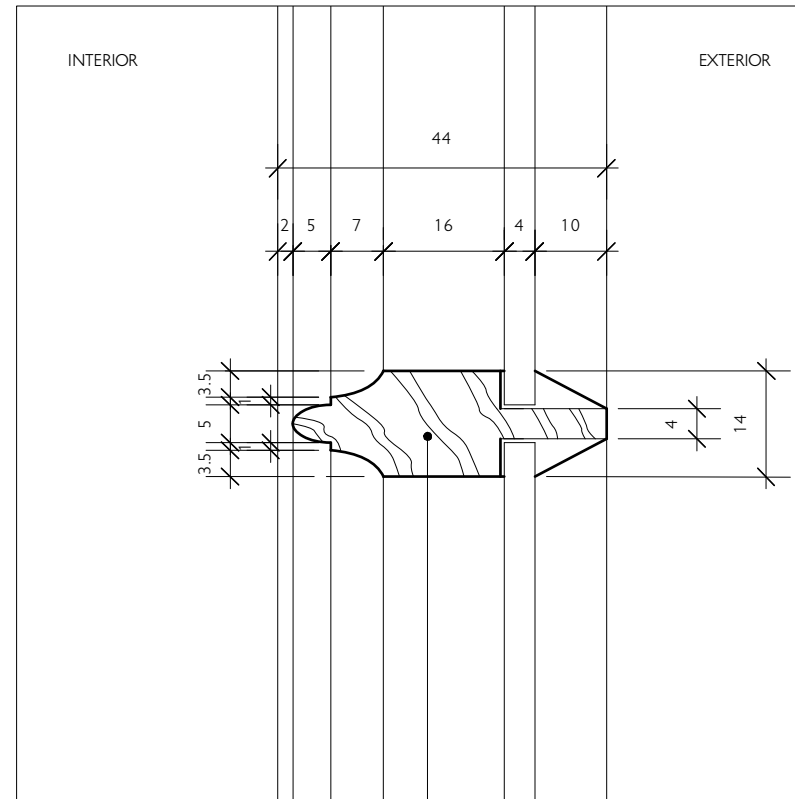

WINDOW SECTION THRU' GLAZING BAR (1:1)

- ⑤

DRAWING REVISIONS: -  
Rev. A: Sept. 2015: Details amended and notes added.

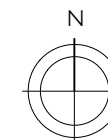

SIR JOHN SOANES MUSEUM  
OPENING UP THE SOANE PH 3

NEW COURT LINK DRG NO. 506MP4/DD59A  
WINDOW DETAILS SCALE 1:2 & 1:1 @ A3  
AS PROPOSED DATE MARCH. 2015

JULIAN HARRAP  
ARCHITECTS LLP

95 KINGSLAND ROAD LONDON E2 8AG  
PHONE 020 7729 5111 FAX 020 7739 8306