



Constant Pressure Variable Volume Inline Dampers

NRG-IL/NRG-IL 125/NRG-IL 150/NRG-IL200

Installation and Maintenance

CE The EMC Directive 2004/108/EC
The Low Voltage directive 2006/95/EC



Introduction

The four motorised inline damper models are designed for installation with Nuaire's range of Ecosmart Constant Pressure Variable Volume extract fans. The units incorporate a fixed damper to set the trickle ventilation flow rate and a wax type 230v driven actuator to increase the flow rate to boost on demand.

Units are rectangular in section, manufactured from pre-galvanised steel and designed to match duct sizes of 100mm, 125mm, 150mm and 200mm.

Dimensions

Figure 1.

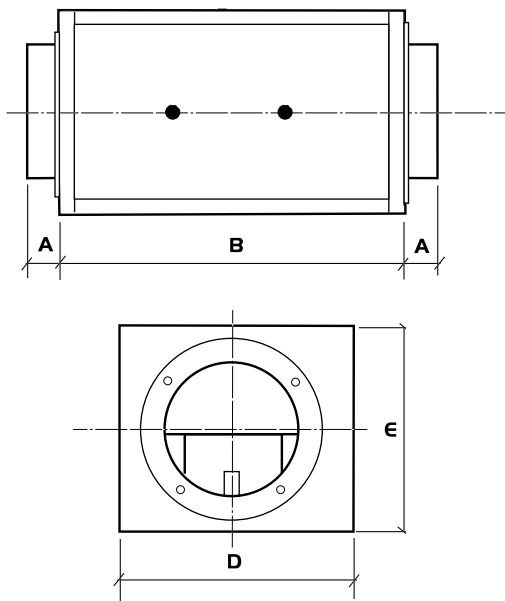

Dimensions in mm.

Unit	A	B	C	D	E
NRG-IL	50	200	100	120	120
NRG-IL125	50	300	125	178	178
NRG-IL150	50	300	150	178	178
NRG-IL200	50	400	200	225	225

Handling

Handle the units carefully to avoid damage and distortion to moving parts.

Performance Detail

Figure 2. Resistance of NRG-IL.

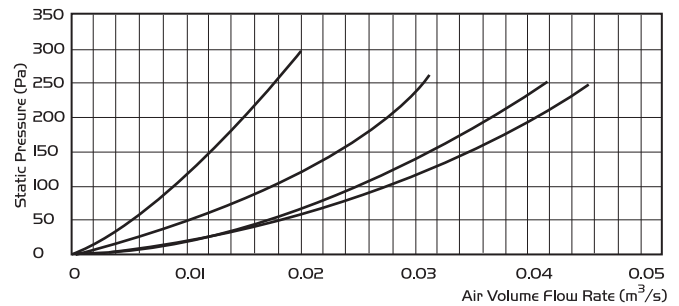

Figure 3. Resistance of NRG-IL125

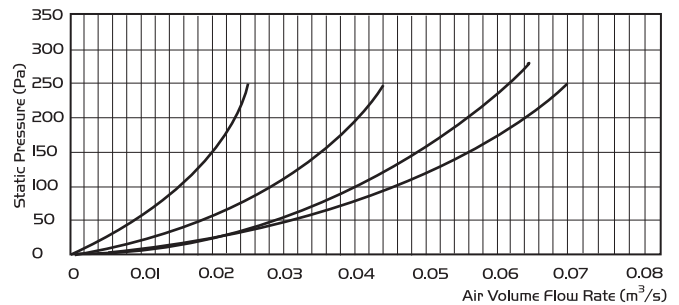

Figure 4. Resistance of NRG-IL150

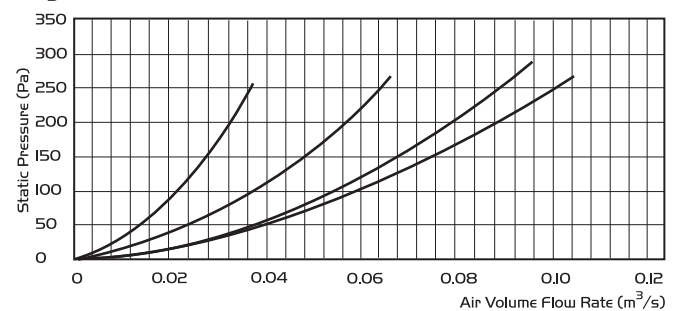
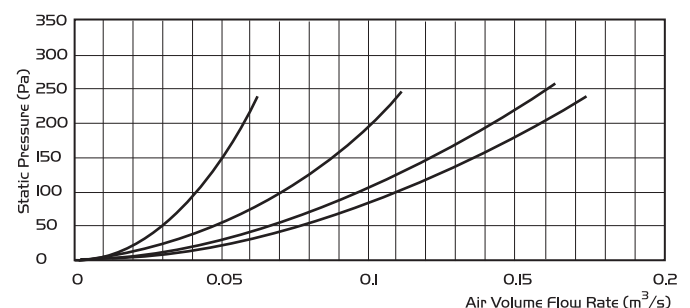

Figure 5. Resistance of NRG-IL200



Acoustic information

Lw	Position 1	Position 2	Position 3	Position 4
70Pa	25.1	21.6	-	23
100Pa	30	30.3	32.2	33.3
130Pa	33.5	32.8	36	37.1
150Pa	37.1	37.3	-	38.6

Installation

The installation must be carried out by suitably qualified and competent personnel in accordance with the appropriate authority and in conformance with all statutory and governing regulations i.e. IEE, CIBSE, COHSE, HVCA etc.

Mechanical installation

The unit can be mounted in any attitude giving due consideration to the accessibility of the access door to complete the electrical connection, set up the damper during commissioning and future maintenance.

A full size access panel is fitted to one side to facilitate electrical connection and damper setting.

The unit should be coupled directly to ductwork of matching spigot diameter and installed behind a ceiling or in a service void and remote from any areas from which it could be subjected to water spray.

Electrical installation

The damper is activated by a 230V mains signal, this signal can be derived from any switching source i.e. light switch, mains PIR, mains rated thermostat, humidistat etc. Offer the mains cable via the cable grommet provided connecting Live (L), Neutral (N) and Earth (E) to the appropriate terminals

Figure 6. Wiring diagram

Third party switching device e.g. Room light switch, PIR, Humidistat etc.

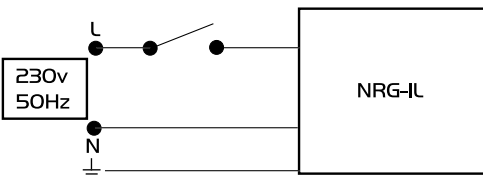

Setting the dampers

Trickle ventilation; minimum trickle rate is pre set by the free area cut around the motorised damper. To increase the trickle ventilation rate remove one of motorised damper cheek plates (A1), to further increase the trickle rate remove the second cheek plate (A2).

Figure 7. Unit with access panel removed, showing electrical connection and damper setting positions

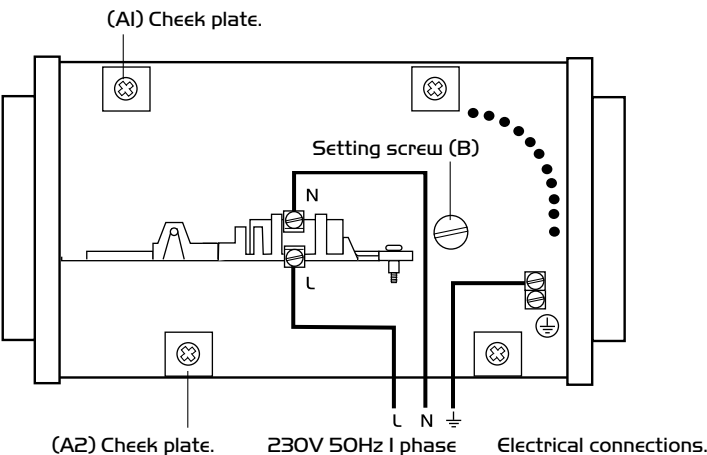

Boost ventilation rate is set by adjusting the setting screw (B), with flow meter connected to duct work and motorised damper activated (by switching on power to unit) adjust the damper position whilst monitoring flow meter until desired boost airflow rate is achieved.

Maintenance

Maintenance intervals will vary according to the level of airborne contaminant to which the unit is exposed; check three months after commissioning and twelve monthly thereafter.

There are no parts requiring lubrication.

Isolate the mains supply, remove the access cover and clean out any dust deposits. Check the security of all components and wire terminations - do not adjust the damper setting screw.

To clean the dampers and internal chamber it will be necessary to remove the unit from the system and access through the inlet/outlet spigots, mark the position of the setting screw (B) and ensure the position is set correctly upon reinstatement.

There are no recommended spares, should the product malfunction then it will require total replacement. Order quoting all the details from the product rating plate.

Warranty

The 3 year warranty starts from the day of delivery and includes parts and labour for the first year.

The remaining 2 years covers replacement parts only.

This warranty is conditional on planned maintenance being undertaken.

Service Enquiries

Nuaire can assist you in all aspects of service. Our service department will be happy to provide any assistance required, initially by telephone and if necessary arrange for an engineer to call.

Telephone 029 2085 8585
Fax 029 2085 8586

Technical or commercial considerations may, from time to time, make it necessary to alter the design, performance and dimensions of equipment and the right is reserved to make such changes without prior notice.