

529400

529600

529800

530000

184800

185000

184800

184800

184600

184600



### Additional SIMs

Published 1980 - 1986

Source map scale - 1:1,250

The SIM cards (Ordnance Survey's 'Survey of Information on Microfilm') are further, minor editions of mapping which were produced and published in between the main editions as an area was updated. They date from 1947 to 1994, and contain detailed information on buildings, roads and land-use. These maps were produced at both 1:2,500 and 1:1,250 scales.

### Map Name(s) and Date(s)

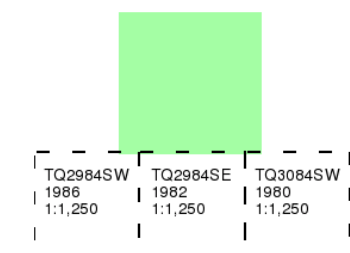

### Historical Map - Segment A13

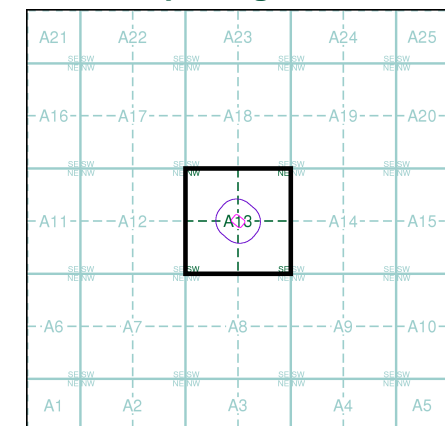

### Order Details

Order Number: 67216162\_1\_1  
 Customer Ref: 12047  
 National Grid Reference: 529740, 184830  
 Slice: A  
 Site Area (Ha): 0.45  
 Search Buffer (m): 100

### Site Details

Ashton Court, 254-256 Camden Road, Camden Town,  
 LONDON, NW1 9HE



Tel: 0844 844 9952  
 Fax: 0844 844 9951  
 Web: www.envirocheck.co.uk

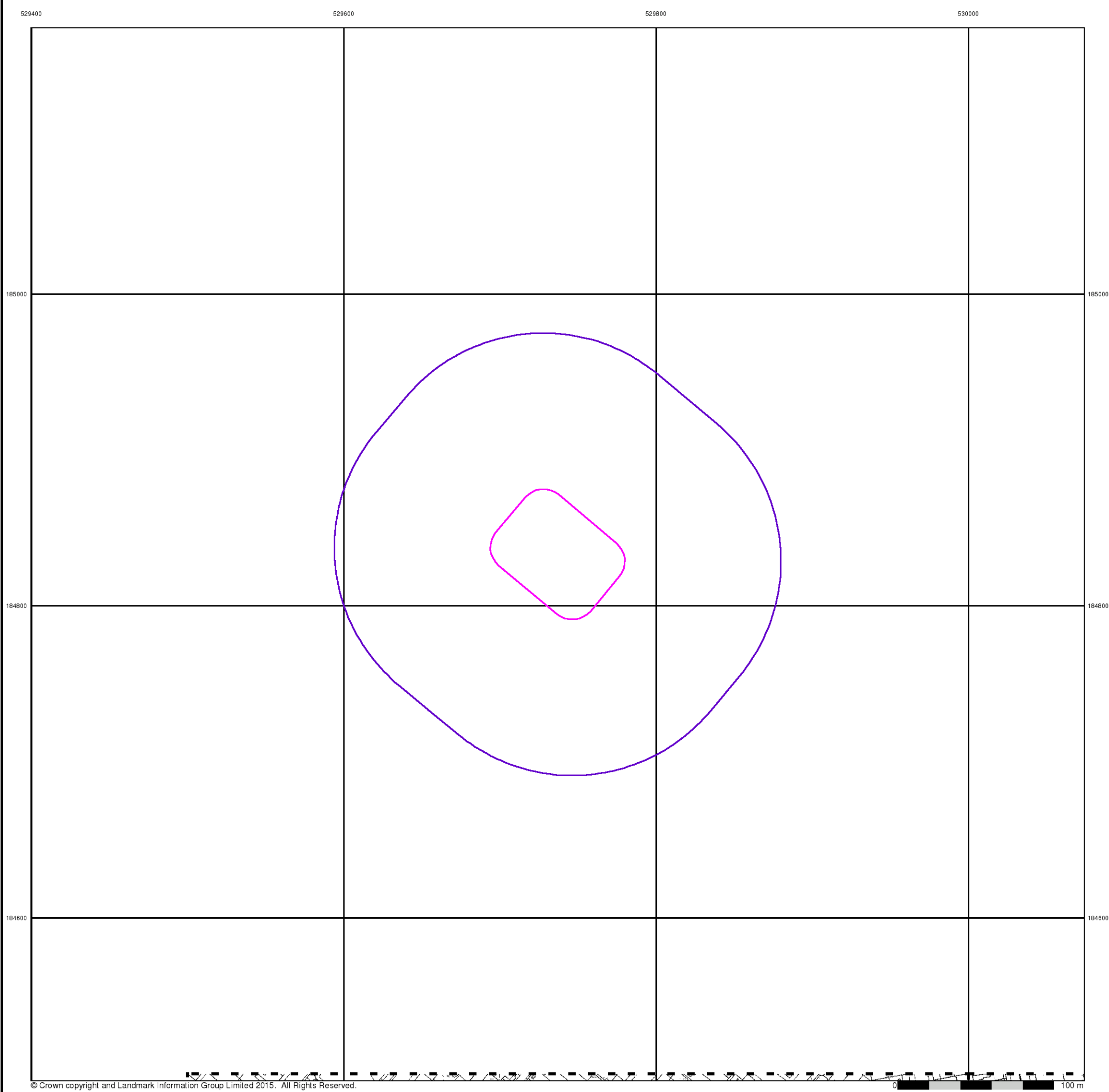

**Additional SIMs**

**Published 1985**

**Source map scale - 1:1,250**

The SIM cards (Ordnance Survey's 'Survey of Information on Microfilm') are further, minor editions of mapping which were produced and published in between the main editions as an area was updated. They date from 1947 to 1994, and contain detailed information on buildings, roads and land-use. These maps were produced at both 1:2,500 and 1:1,250 scales.

**Map Name(s) and Date(s)**

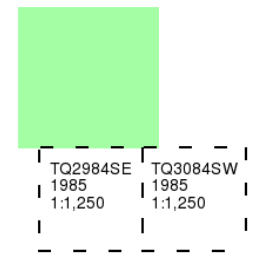

**Historical Map - Segment A13**

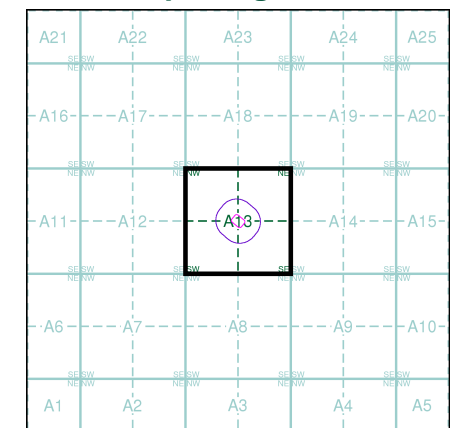

**Order Details**

Order Number: 67216162\_1\_1  
 Customer Ref: 12047  
 National Grid Reference: 529740, 184830  
 Slice: A  
 Site Area (Ha): 0.45  
 Search Buffer (m): 100

**Site Details**

Ashton Court, 254-256 Camden Road, Camden Town, LONDON, NW1 9HE



Tel: 0844 844 9952  
 Fax: 0844 844 9951  
 Web: www.envirocheck.co.uk

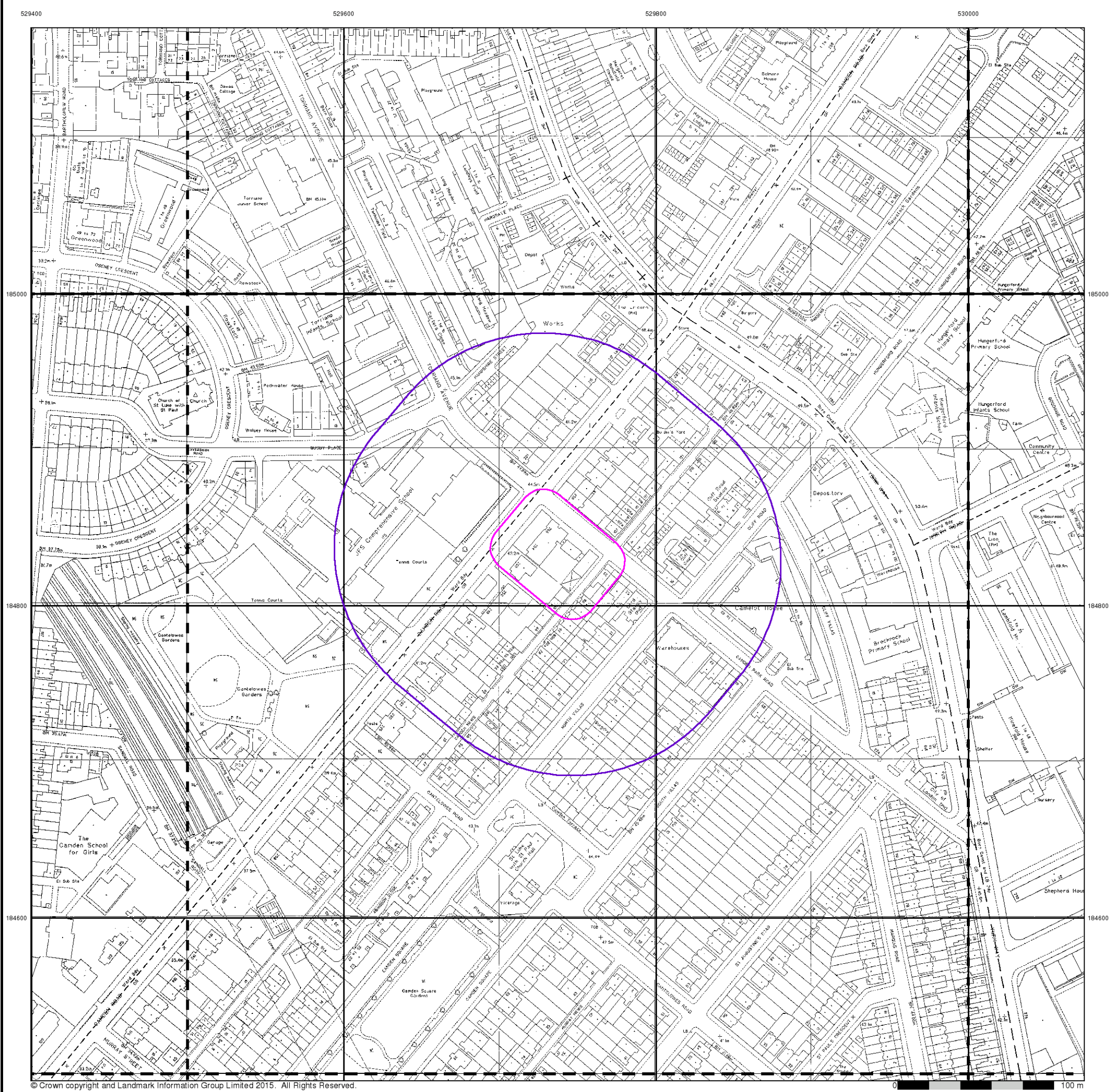

**Large-Scale National Grid Data**  
**Published 1991**  
**Source map scale - 1:1,250**

'Large Scale National Grid Data' superseded SIM cards (Ordnance Survey's 'Survey of Information on Microfilm') in 1992, and continued to be produced until 1999. These maps were the fore-runners of digital mapping and so provide detailed information on houses and roads, but tend to show less topographic features such as vegetation. These maps were produced at both 1:2,500 and 1:1,250 scales.

**Map Name(s) and Date(s)**

Q2985SW	Q2985SE	Q3085SW
1991	1991	1991
1:1,250	1:1,250	1:1,250
Q2984NW	Q2984NE	Q3084NW
1991	1991	1991
1:1,250	1:1,250	1:1,250
Q2984S	Q2984SE	Q3084S
1991	1991	1991
1:1,250	1:1,250	1:1,250

**Historical Map - Segment A13**

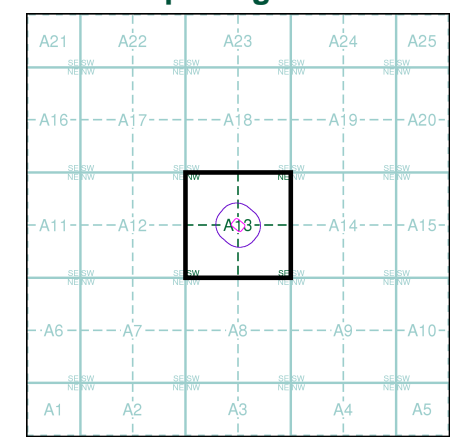

**Order Details**

Order Number: 67216162\_1\_1  
 Customer Ref: 12047  
 National Grid Reference: 529740, 184830  
 Slice: A  
 Site Area (Ha): 0.45  
 Search Buffer (m): 100

**Site Details**

Ashton Court, 254-256 Camden Road, Camden Town, LONDON, NW1 9HE



Tel: 0844 844 9952  
 Fax: 0844 844 9951  
 Web: www.envirocheck.co.uk

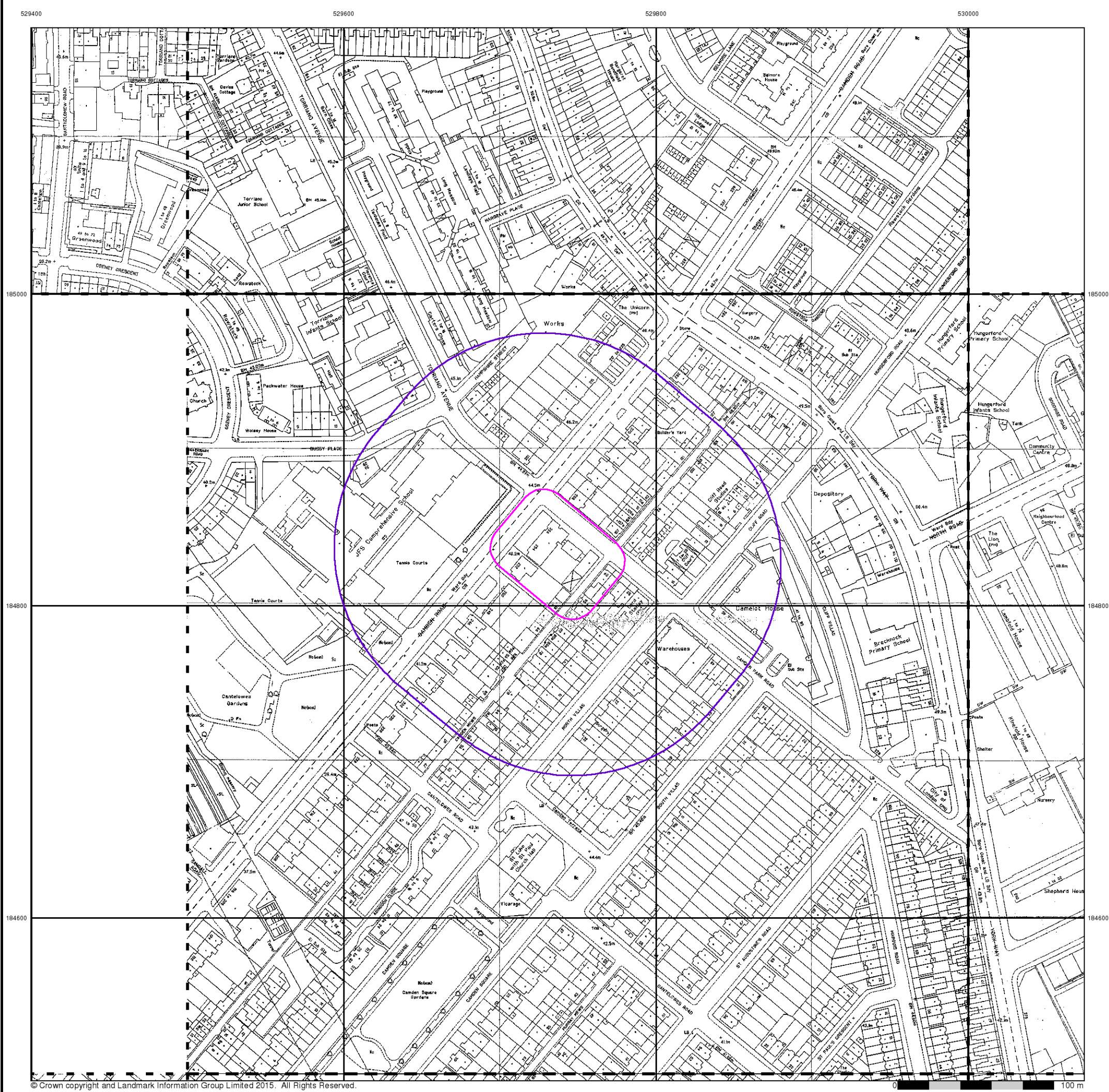

**Large-Scale National Grid Data**  
**Published 1992 - 1995**  
**Source map scale - 1:1,250**

'Large Scale National Grid Data' superseded SIM cards (Ordnance Survey's 'Survey of Information on Microfilm') in 1992, and continued to be produced until 1999. These maps were the fore-runners of digital mapping and so provide detailed information on houses and roads, but tend to show less topographic features such as vegetation. These maps were produced at both 1:2,500 and 1:1,250 scales.

**Map Name(s) and Date(s)**

Q2985SW	Q2985SE						
1995	1992						
1:1,250	1:1,250						
<table border="1"> <tr> <td>Q2984NE</td> <td>Q3084NW</td> </tr> <tr> <td>1992</td> <td>1994</td> </tr> <tr> <td>1:1,250</td> <td>1:1,250</td> </tr> </table>		Q2984NE	Q3084NW	1992	1994	1:1,250	1:1,250
Q2984NE	Q3084NW						
1992	1994						
1:1,250	1:1,250						
Q2984SW	Q2984SE	Q3084SW					
1992	1993	1993					
1:1,250	1:1,250	1:1,250					

**Historical Map - Segment A13**

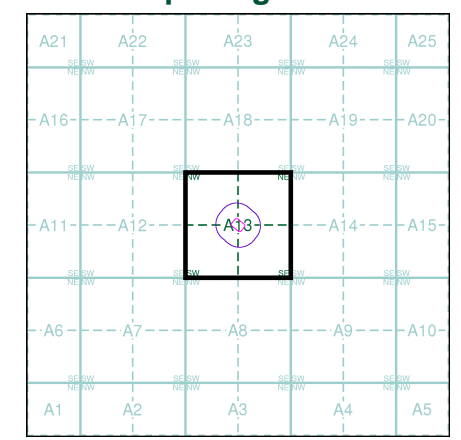

**Order Details**

Order Number: 67216162\_1\_1  
 Customer Ref: 12047  
 National Grid Reference: 529740, 184830  
 Slice: A  
 Site Area (Ha): 0.45  
 Search Buffer (m): 100

**Site Details**

Ashton Court, 254-256 Camden Road, Camden Town, LONDON, NW1 9HE



Tel: 0844 844 9952  
 Fax: 0844 844 9951  
 Web: www.envirocheck.co.uk

529400

529600

529800

530000

184800

185000

184800

184800

184600

184600



### Large-Scale National Grid Data

Published 1994

Source map scale - 1:1,250

'Large Scale National Grid Data' superseded SIM cards (Ordnance Survey's 'Survey of Information on Microfilm') in 1992, and continued to be produced until 1999. These maps were the fore-runners of digital mapping and so provide detailed information on houses and roads, but tend to show less topographic features such as vegetation. These maps were produced at both 1:2,500 and 1:1,250 scales.

### Map Name(s) and Date(s)

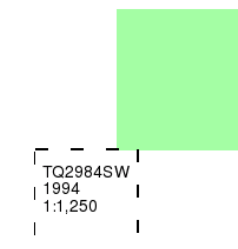

### Historical Map - Segment A13

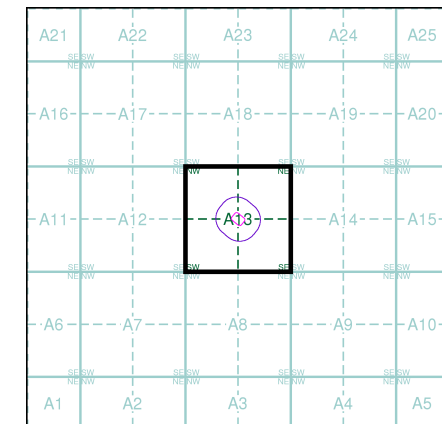

### Order Details

Order Number: 67216162\_1\_1  
Customer Ref: 12047  
National Grid Reference: 529740, 184830  
Slice: A  
Site Area (Ha): 0.45  
Search Buffer (m): 100

### Site Details

Ashton Court, 254-256 Camden Road, Camden Town, LONDON, NW1 9HE



© Crown copyright and Landmark Information Group Limited 2015. All Rights Reserved.

0 100 m



Tel: 0844 844 9952  
Fax: 0844 844 9951  
Web: www.envirocheck.co.uk

529400

529600

529800

530000

184800

185000

184800

184800

184600

184600



### Large-Scale National Grid Data

Published 1995

Source map scale - 1:1,250

'Large Scale National Grid Data' superseded SIM cards (Ordnance Survey's 'Survey of Information on Microfilm') in 1992, and continued to be produced until 1999. These maps were the fore-runners of digital mapping and so provide detailed information on houses and roads, but tend to show less topographic features such as vegetation. These maps were produced at both 1:2,500 and 1:1,250 scales.

### Map Name(s) and Date(s)

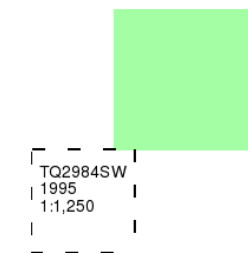

### Historical Map - Segment A13

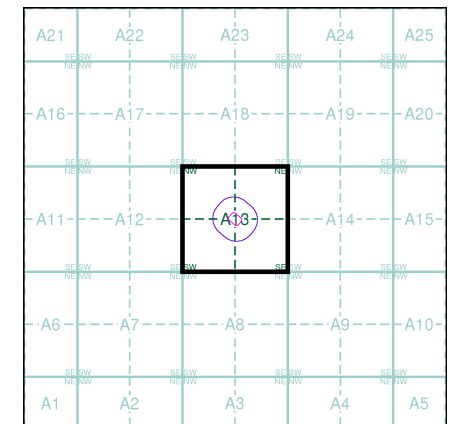

### Order Details

Order Number: 67216162\_1\_1  
Customer Ref: 12047  
National Grid Reference: 529740, 184830  
Slice: A  
Site Area (Ha): 0.45  
Search Buffer (m): 100

### Site Details

Ashton Court, 254-256 Camden Road, Camden Town, LONDON, NW1 9HE



© Crown copyright and Landmark Information Group Limited 2015. All Rights Reserved.

0 100 m



Tel: 0844 844 9952  
Fax: 0844 844 9951  
Web: www.envirocheck.co.uk

## Large-Scale National Grid Data

Published 1996

Source map scale - 1:1,250

'Large Scale National Grid Data' superseded SIM cards (Ordnance Survey's 'Survey of Information on Microfilm') in 1992, and continued to be produced until 1999. These maps were the fore-runners of digital mapping and so provide detailed information on houses and roads, but tend to show less topographic features such as vegetation. These maps were produced at both 1:2,500 and 1:1,250 scales.

### Map Name(s) and Date(s)

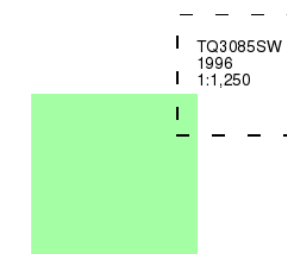

### Historical Map - Segment A13

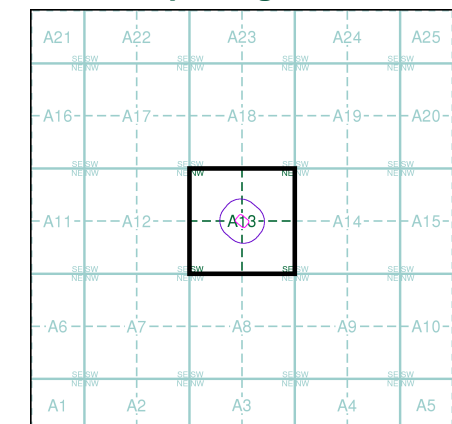

### Order Details

Order Number: 67216162\_1\_1  
 Customer Ref: 12047  
 National Grid Reference: 529740, 184830  
 Slice: A  
 Site Area (Ha): 0.45  
 Search Buffer (m): 100

### Site Details

Ashton Court, 254-256 Camden Road, Camden Town,  
 LONDON, NW1 9HE

185000

184800

184600

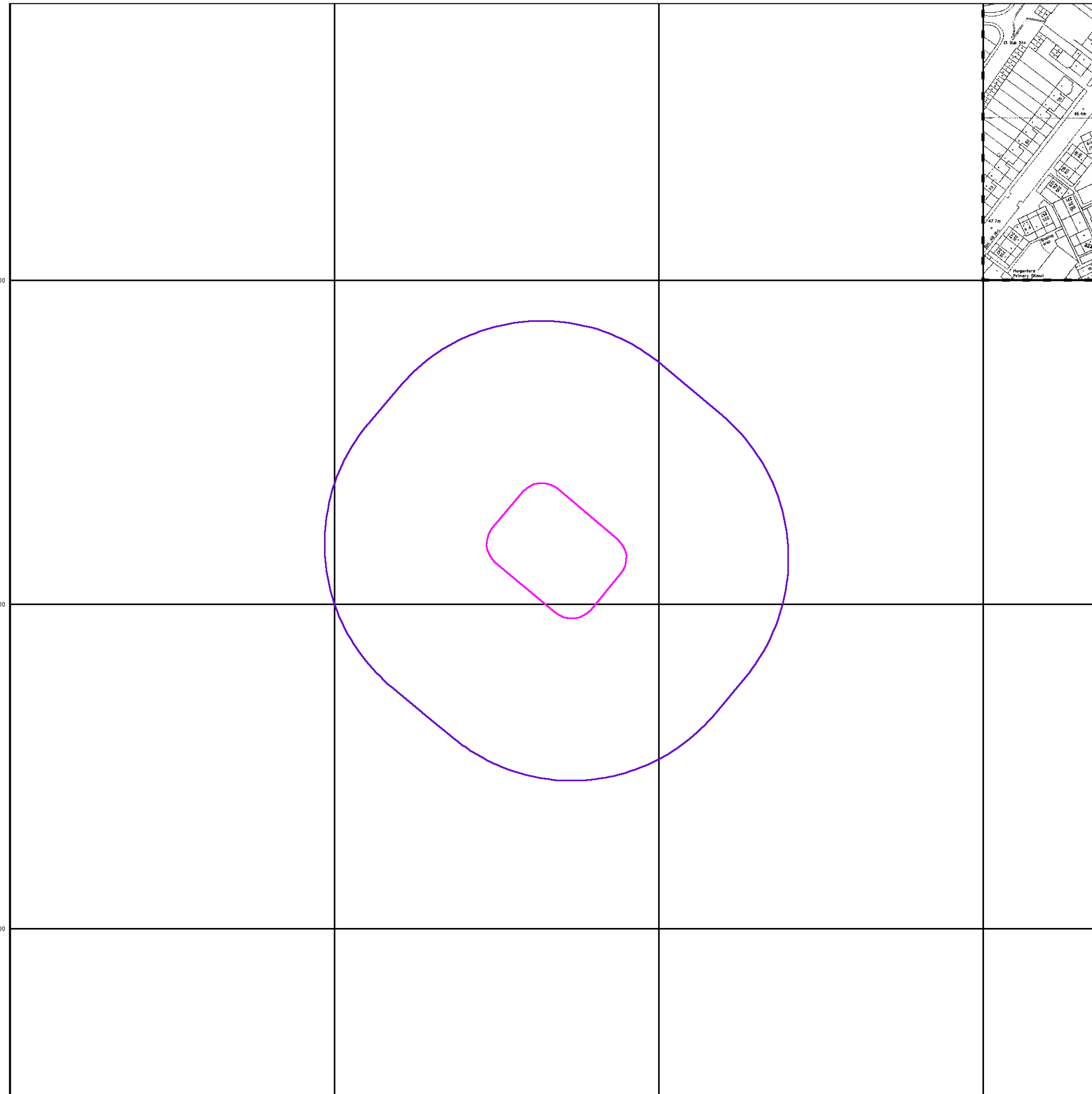

# Historical Mapping Legends

## Ordnance Survey County Series 1:10,560

	Gravel Pit		Sand Pit		Other Pits
	Quarry		Shingle		Orchard
	Osiers		Reeds		Marsh
	Mixed Wood		Deciduous		Brushwood
	Fir		Furze		Rough Pasture
	Arrow denotes flow of water		Trigonometrical Station		
	Site of Antiquities		Bench Mark		
	Pump, Guide Post, Signal Post		Well, Spring, Boundary Post		
	<b>-285</b> Surface Level				
	Sketched Contour		Instrumental Contour		
	Main Roads		Minor Roads		
	Sunken Road		Raised Road		
	Road over Railway		Railway over River		
	Railway over Road		Level Crossing		
	Road over River or Canal		Road over Stream		
	Road over Stream				
	County Boundary (Geographical)				
	County & Civil Parish Boundary				
	Administrative County & Civil Parish Boundary				
	County Borough Boundary (England)				
	County Burgh Boundary (Scotland)				
	Rural District Boundary				
	Civil Parish Boundary				

## Ordnance Survey Plan 1:10,000

	Chalk Pit, Clay Pit or Quarry		Gravel Pit
	Sand Pit		Disused Pit or Quarry
	Refuse or Slag Heap		Lake, Loch or Pond
	Dunes		Boulders
	Coniferous Trees		Non-Coniferous Trees
	Orchard		Scrub
	Coppice		Bracken
	Heath		Rough Grassland
	Marsh		Reeds
	Saltings		
	Building		Glasshouse
	Sloping Masonry		Pylon
	Electricity Transmission Line		Pole
	Cutting		Embankment
	Standard Gauge Multiple Track		Standard Gauge Single Track
	Siding, Tramway or Mineral Line		Narrow Gauge
	Geographical County		
	Administrative County, County Borough or County of City		
	Municipal Borough, Urban or Rural District, Burgh or District Council		
	Borough, Burgh or County Constituency Shown only when not coincident with other boundaries		
	Civil Parish Shown alternately when coincidence of boundaries occurs		
	BP, BS Boundary Post or Stone		Pol Sta Police Station
	Ch Church		PO Post Office
	CH Club House		PC Public Convenience
	F E Sta Fire Engine Station		PH Public House
	FB Foot Bridge		SB Signal Box
	Fn Fountain		Spr Spring
	GP Guide Post		TCB Telephone Call Box
	MP Mile Post		TCP Telephone Call Post
	MS Mile Stone		W Well

## 1:10,000 Raster Mapping

	Gravel Pit		Refuse tip or slag heap
	Rock		Rock (scattered)
	Boulders		Boulders (scattered)
	Shingle		Mud
	Sand		Sand Pit
	Slopes		Top of cliff
	General detail		Underground detail
	Overhead detail		Narrow gauge railway
	Multi-track railway		Single track railway
	County boundary (England only)		Civil, parish or community boundary
	District, Unitary, Metropolitan, London Borough boundary		Constituency boundary
	Area of wooded vegetation		Non-coniferous trees
	Non-coniferous trees (scattered)		Coniferous trees
	Coniferous trees (scattered)		Positioned tree
	Orchard		Coppice or Osiers
	Rough Grassland		Heath
	Scrub		Marsh, Salt Marsh or Reeds
	Water feature		Flow arrows
	MHW(S) Mean high water (springs)		MLW(S) Mean low water (springs)
	Telephone line (where shown)		Electricity transmission line (with poles)
	Bench mark (where shown)		Triangulation station
	Point feature (e.g. Guide Post or Mile Stone)		Pylon, flare stack or lighting tower
	Site of (antiquity)		Glasshouse
	General Building		Important Building

## Historical Mapping & Photography included:

Mapping Type	Scale	Date	Pg
Middlesex	1:10,560	1873 - 1882	3
Middlesex	1:10,560	1879	4
London	1:10,560	1896	5
Essex	1:10,560	1920	6
London	1:10,560	1920	7
Essex	1:10,560	1938	8
London	1:10,560	1938	9
Ordnance Survey Plan	1:10,000	1940 - 1951	10
Historical Aerial Photography	1:10,560	1949 - 1950	11
Ordnance Survey Plan	1:10,000	1957 - 1958	12
Ordnance Survey Plan	1:10,000	1962 - 1968	13
Ordnance Survey Plan	1:10,000	1967	14
Ordnance Survey Plan	1:10,000	1972 - 1976	15
Ordnance Survey Plan	1:10,000	1979	16
Ordnance Survey Plan	1:10,000	1984	17
London	1:25,000	1985	18
Ordnance Survey Plan	1:10,000	1990 - 1996	19
10K Raster Mapping	1:10,000	2006	20
VectorMap Local	1:10,000	2015	21

## Historical Map - Slice A

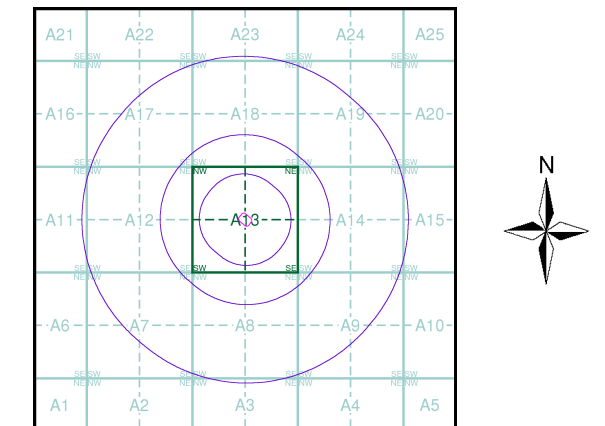

## Order Details

Order Number: 67216162\_1\_1  
 Customer Ref: 12047  
 National Grid Reference: 529740, 184830  
 Slice: A  
 Site Area (Ha): 0.45  
 Search Buffer (m): 1000

## Site Details

Ashton Court, 254-256 Camden Road, Camden Town, LONDON, NW1 9HE



# Russian Military Mapping Legends

## 1:5,000 and 1:10,000 mapping

a. Not drawn to scale b. Drawn to scale

	Government and Administrative Buildings		Military and Industrial Buildings
	Military and Communication Areas		Subway Entrance
	Fireproof Building		Prominent Fireproof Building
	Non-fireproof Building		Non-fireproof Building (non-dwelling)
	Factory, mill, and flour mill, with chimneys		Factory, mill, and flour mill, without chimneys
	Power Station, drawn to scale		Hydroelectric Power Station
	Radio Station, drawn to scale		Telephone Station, drawn to scale
	Abandoned Open-pit Mine or Quarry		Open-pit Salt Mine
	Pit		Oil Deposit or Well
	Oil Seepage		Natural Gas Tank
	Tailings Pile		Fuel Storage Tanks
	Bench Mark		Drill Hole
	Burial Mound		Triangulation Point on Burial Mound
	Single-track Railroad		Double-track Railroad
	Small Bridge		Pipe (Culvert)
	Tunnel		Railroad and Station Building
	Coniferous Forest		Deciduous Forest
	Mixed Forest		Lawns
	Citrus Orchard		Wet Ground
	Scattered Vegetation		

**243,8** Values for prominent elevations  
**186.0** Numbers for spot elevations, depth soundings, contour lines, etc.  
**0,2** Velocity of the current, width of river bed, depth of river  
**180/12** Fractional terms: length and capacity of bridges; depth of fords and condition of the river bottom; height of forest and the diameter of trees

### Russian Alphabet (For reference and phonetic interpretation of map text)

<b>А а (A)</b>	<b>З з (Z)</b>	<b>П п (P)</b>	<b>Ч ч (CH)</b>
<b>Б б (B)</b>	<b>И и (I)</b>	<b>Р р (R)</b>	<b>Ш ш (SH)</b>
<b>В в (V)</b>	<b>Й й (Y)</b>	<b>С с (S)</b>	<b>Щ щ (SHCH)</b>
<b>Г г (G)</b>	<b>К к (K)</b>	<b>Т т (T)</b>	<b>Ъ (-)</b>
<b>Д д (D)</b>	<b>Л л (L)</b>	<b>У у (U)</b>	<b>Ы (Y)</b>
<b>Е е (E)</b>	<b>М м (M)</b>	<b>Ф ф (F)</b>	<b>Ь (')</b>
<b>Ё ё (YO)</b>	<b>Н н (N)</b>	<b>Х х (KH)</b>	<b>Э э (E)</b>
<b>Ж ж (ZH)</b>	<b>О о (O)</b>	<b>Ц ц (TS)</b>	<b>Ю ю (YU or IU)</b>
			<b>Я я (YA or IA)</b>

## 1:25,000 mapping

a. Not drawn to scale b. Drawn to scale

	Government and Administrative Buildings		Military and Industrial Buildings
	Military and Communication Areas		Subway Entrance
	Partly Demolished Buildings		Demolished Buildings
	Built-Up Area with Fireproof Buildings Predominant		Built-Up Area with Non-Fireproof Buildings Predominant
	Individual Fireproof Building		Prominent Industrial Building
	Individual Dwelling, Fireproof		Ruins of an Individual Dwelling
	Factory or Mill Chimney		Factory or Mill with Chimney
	Factory or Mill without Chimney		Mine or Open Pit Mine
	Operating Shaft or Mine		Non-Operating Shaft or Mine
	Salt Mine		Tailings Pile
	Pit		Stone Quarry
	Gas Pump or Service Station		Fuel Storage or Natural Gas Tank
	Oil or Natural Gas Derrick		Small Hydroelectric Power Station
	Power Station		Transformer Station
	Cemetery		Burial Mound (height in metres)
	Triangulation Point on Burial Mound		Triangulation Point
	Bench Mark		Telegraph Office
	Telephone Station		Radio Station
	Radio Tower		Airfield or Seaplane Base
	Landing Strip		Cut
	Fill		Km Post
	Plantings		Width of Road
	Steep Grade		Highway under Construction
	Improved Dirt Road (former truck road)		Small Bridge
	Pipe (Culvert)		Tunnel
	Dismantled Railroad		Double-track Railroad with First Class Station
	Railroad Under Construction		Shore Embankment
	River or Ditch with Embankment		Water Gauge
	Direction and velocity of current		Water Level Mark
	Well		Water Reservoir or Rain Water Pit
	Spring		Isobath with value
	Heavy (Index) Contour Line		Contour Line and Value
	Half Contour Line		Spot Elevation Value
	Coniferous		Deciduous
	Mixed		Scrub

## Key to Numbers on Mapping

### TQ38\_London

No.	Description
330	Prison



## Historical Mapping & Photography included:

Mapping Type	Scale	Date	Pg
Middlesex	1:10,560	1873 - 1882	3
Middlesex	1:10,560	1879	4
London	1:10,560	1896	5
Essex	1:10,560	1920	6
London	1:10,560	1920	7
Essex	1:10,560	1938	8
London	1:10,560	1938	9
Ordnance Survey Plan	1:10,000	1940 - 1951	10
Historical Aerial Photography	1:10,560	1949 - 1950	11
Ordnance Survey Plan	1:10,000	1957 - 1958	12
Ordnance Survey Plan	1:10,000	1962 - 1968	13
Ordnance Survey Plan	1:10,000	1967	14
Ordnance Survey Plan	1:10,000	1972 - 1976	15
Ordnance Survey Plan	1:10,000	1979	16
Ordnance Survey Plan	1:10,000	1984	17
London	1:25,000	1985	18
Ordnance Survey Plan	1:10,000	1990 - 1996	19
10K Raster Mapping	1:10,000	2006	20
VectorMap Local	1:10,000	2015	21

## Russian Map - Slice A

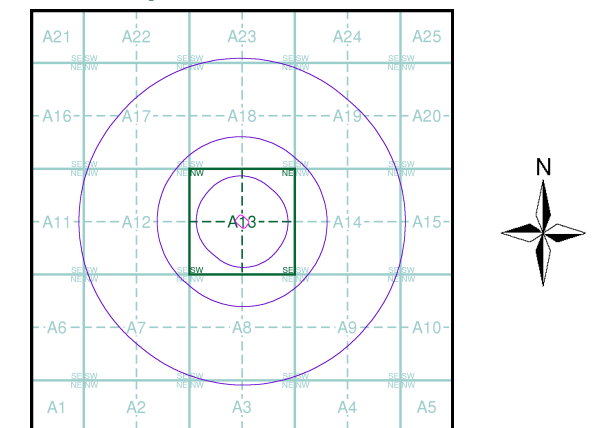

## Order Details

Order Number: 67216162\_1\_1  
 Customer Ref: 12047  
 National Grid Reference: 529740, 184830  
 Slice: A  
 Site Area (Ha): 0.45  
 Search Buffer (m): 1000

## Site Details

Ashton Court, 254-256 Camden Road, Camden Town, LONDON, NW1 9HE



Tel: 0844 844 9952  
 Fax: 0844 844 9951  
 Web: www.envirocheck.co.uk

## Middlesex

Published 1873 - 1882

Source map scale - 1:10,560

The historical maps shown were reproduced from maps predominantly held at the scale adopted for England, Wales and Scotland in the 1840's. In 1854 the 1:2,500 scale was adopted for mapping urban areas; these maps were used to update the 1:10,560 maps. The published date given therefore is often some years later than the surveyed date. Before 1938, all OS maps were based on the Cassini Projection, with independent surveys of a single county or group of counties, giving rise to significant inaccuracies in outlying areas. In the late 1940's, a Provisional Edition was produced, which updated the 1:10,560 mapping from a number of sources. The maps appear unfinished - with all military camps and other strategic sites removed. These maps were initially overprinted with the National Grid. In 1970, the first 1:10,000 maps were produced using the Transverse Mercator Projection. The revision process continued until recently, with new editions appearing every 10 years or so for urban areas.

### Map Name(s) and Date(s)

01200	1873	1:10,560
01700	1882	1:10,560

### Historical Map - Slice A

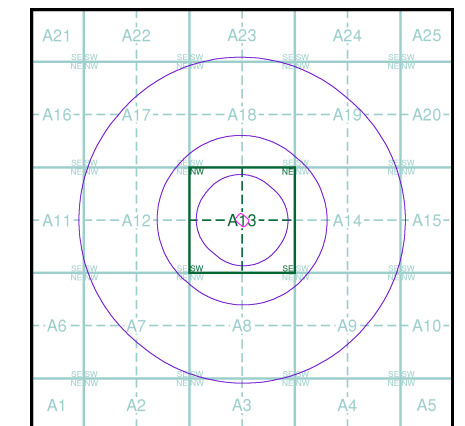

### Order Details

Order Number: 67216162\_1\_1  
 Customer Ref: 12047  
 National Grid Reference: 529740, 184830  
 Slice: A  
 Site Area (Ha): 0.45  
 Search Buffer (m): 1000

### Site Details

Ashton Court, 254-256 Camden Road, Camden Town, LONDON, NW1 9HE

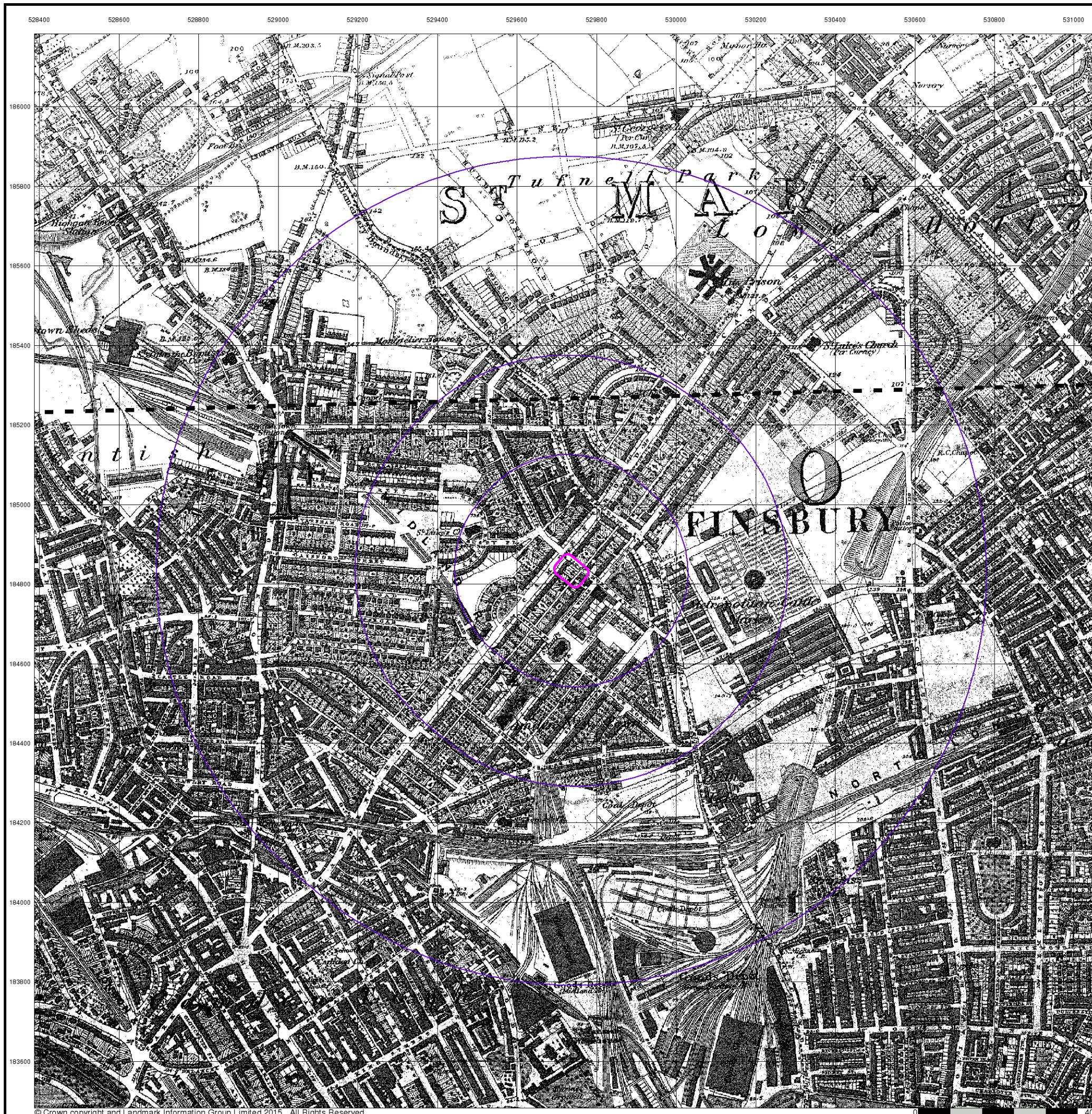

## Middlesex

Published 1879

Source map scale - 1:10,560

The historical maps shown were reproduced from maps predominantly held at the scale adopted for England, Wales and Scotland in the 1840's. In 1854 the 1:2,500 scale was adopted for mapping urban areas; these maps were used to update the 1:10,560 maps. The published date given therefore is often some years later than the surveyed date. Before 1938, all OS maps were based on the Cassini Projection, with independent surveys of a single county or group of counties, giving rise to significant inaccuracies in outlying areas. In the late 1940's, a Provisional Edition was produced, which updated the 1:10,560 mapping from a number of sources. The maps appear unfinished - with all military camps and other strategic sites removed. These maps were initially overprinted with the National Grid. In 1970, the first 1:10,000 maps were produced using the Transverse Mercator Projection. The revision process continued until recently, with new editions appearing every 10 years or so for urban areas.

### Map Name(s) and Date(s)

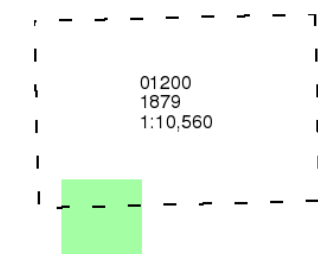

### Historical Map - Slice A

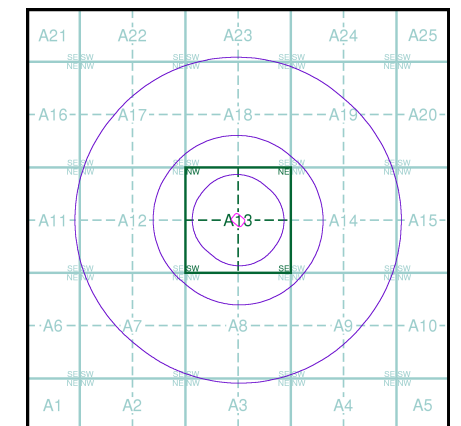

### Order Details

Order Number: 67216162\_1\_1  
 Customer Ref: 12047  
 National Grid Reference: 529740, 184830  
 Slice: A  
 Site Area (Ha): 0.45  
 Search Buffer (m): 1000

### Site Details

Ashton Court, 254-256 Camden Road, Camden Town, LONDON, NW1 9HE

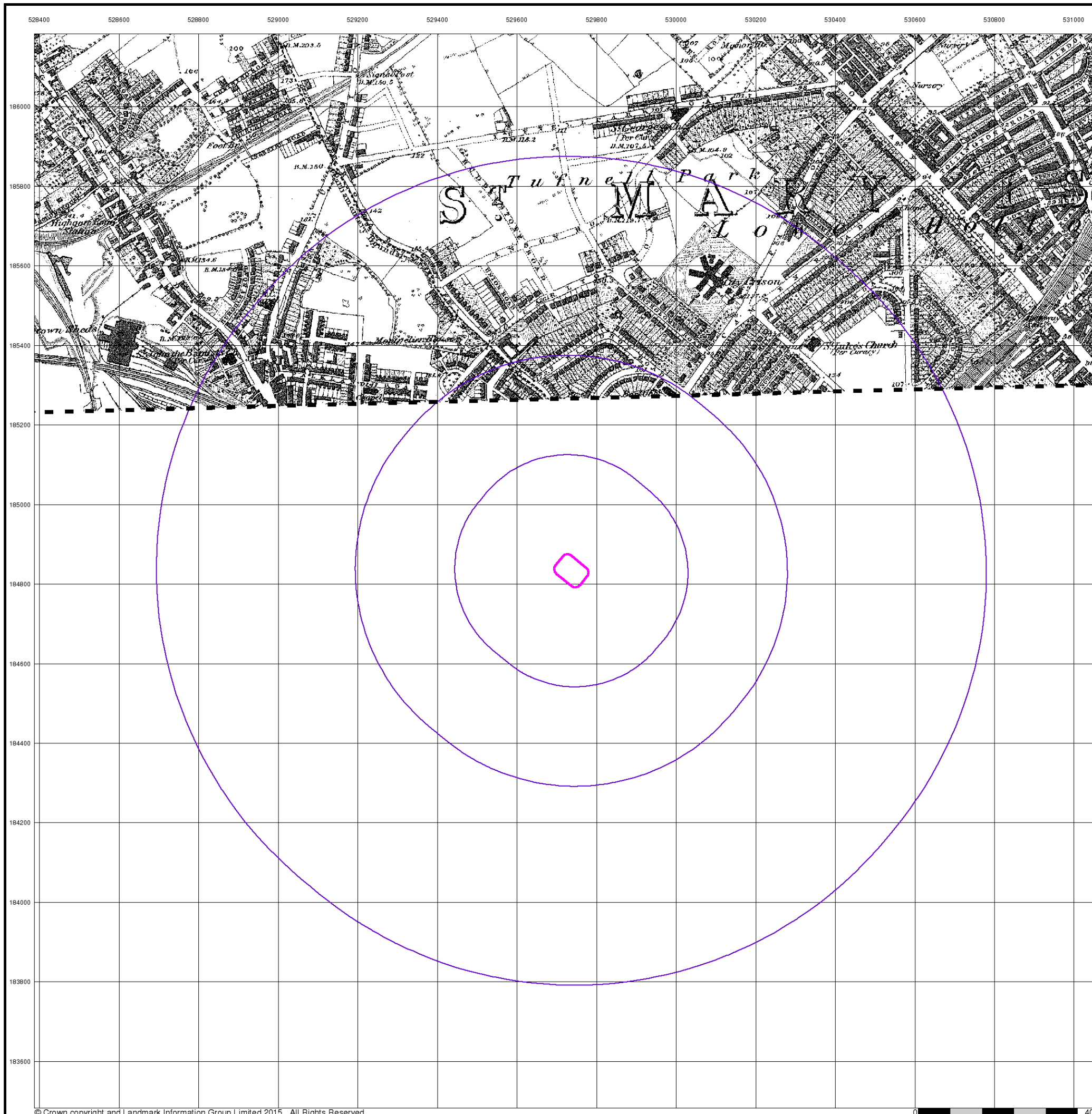

## London

Published 1896

Source map scale - 1:10,560

The historical maps shown were reproduced from maps predominantly held at the scale adopted for England, Wales and Scotland in the 1840's. In 1854 the 1:2,500 scale was adopted for mapping urban areas; these maps were used to update the 1:10,560 maps. The published date given therefore is often some years later than the surveyed date. Before 1938, all OS maps were based on the Cassini Projection, with independent surveys of a single county or group of counties, giving rise to significant inaccuracies in outlying areas. In the late 1940's, a Provisional Edition was produced, which updated the 1:10,560 mapping from a number of sources. The maps appear unfinished - with all military camps and other strategic sites removed. These maps were initially overprinted with the National Grid. In 1970, the first 1:10,000 maps were produced using the Transverse Mercator Projection. The revision process continued until recently, with new editions appearing every 10 years or so for urban areas.

### Map Name(s) and Date(s)

003SW	1896	1:10,560
007NW	1896	1:10,560

### Historical Map - Slice A

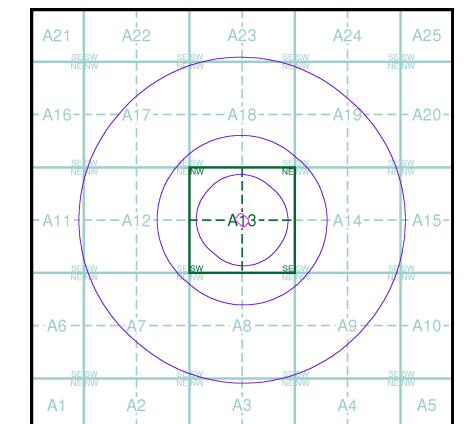

### Order Details

Order Number: 67216162\_1\_1  
 Customer Ref: 12047  
 National Grid Reference: 529740, 184830  
 Slice: A  
 Site Area (Ha): 0.45  
 Search Buffer (m): 1000

### Site Details

Ashton Court, 254-256 Camden Road, Camden Town, LONDON, NW1 9HE

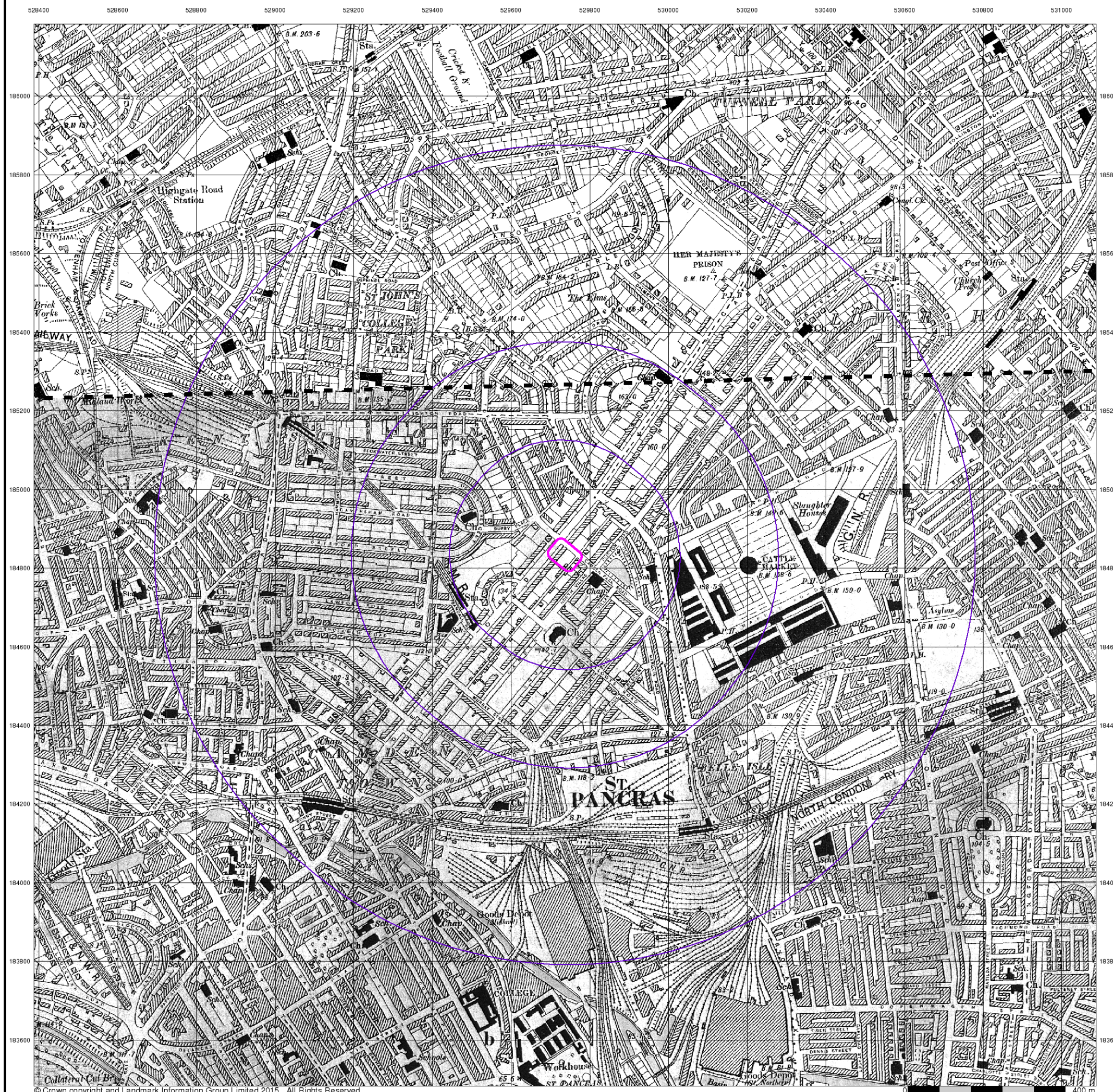

## Essex

Published 1920

Source map scale - 1:10,560

The historical maps shown were reproduced from maps predominantly held at the scale adopted for England, Wales and Scotland in the 1840's. In 1854 the 1:2,500 scale was adopted for mapping urban areas; these maps were used to update the 1:10,560 maps. The published date given therefore is often some years later than the surveyed date. Before 1938, all OS maps were based on the Cassini Projection, with independent surveys of a single county or group of counties, giving rise to significant inaccuracies in outlying areas. In the late 1940's, a Provisional Edition was produced, which updated the 1:10,560 mapping from a number of sources. The maps appear unfinished - with all military camps and other strategic sites removed. These maps were initially overprinted with the National Grid. In 1970, the first 1:10,000 maps were produced using the Transverse Mercator Projection. The revision process continued until recently, with new editions appearing every 10 years or so for urban areas.

### Map Name(s) and Date(s)

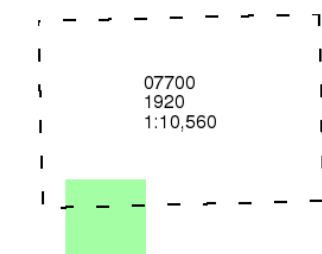

### Historical Map - Slice A

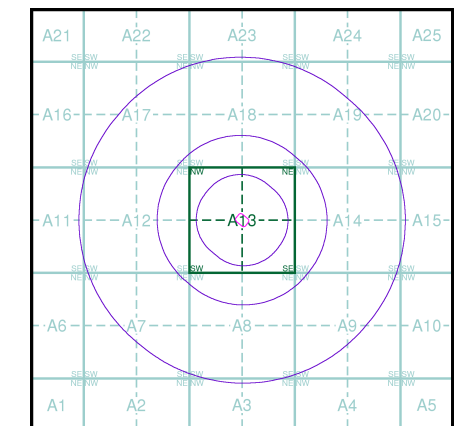

### Order Details

Order Number: 67216162\_1\_1  
 Customer Ref: 12047  
 National Grid Reference: 529740, 184830  
 Slice: A  
 Site Area (Ha): 0.45  
 Search Buffer (m): 1000

### Site Details

Ashton Court, 254-256 Camden Road, Camden Town,  
 LONDON, NW1 9HE

