

History Maps - 1870



History Maps – 1916



Appendix E

Camden Geological, Hydrogeological + Hydrological Maps

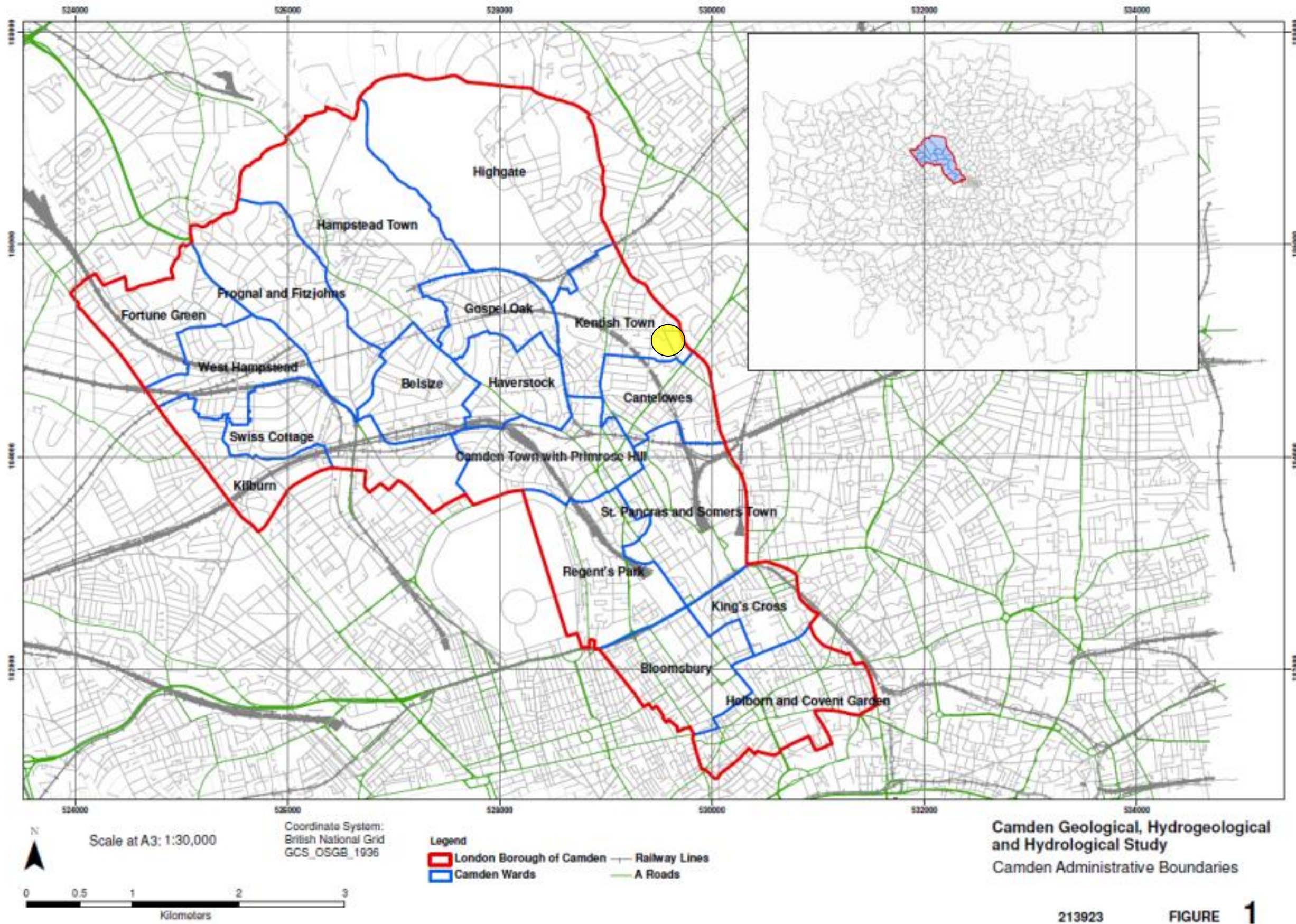

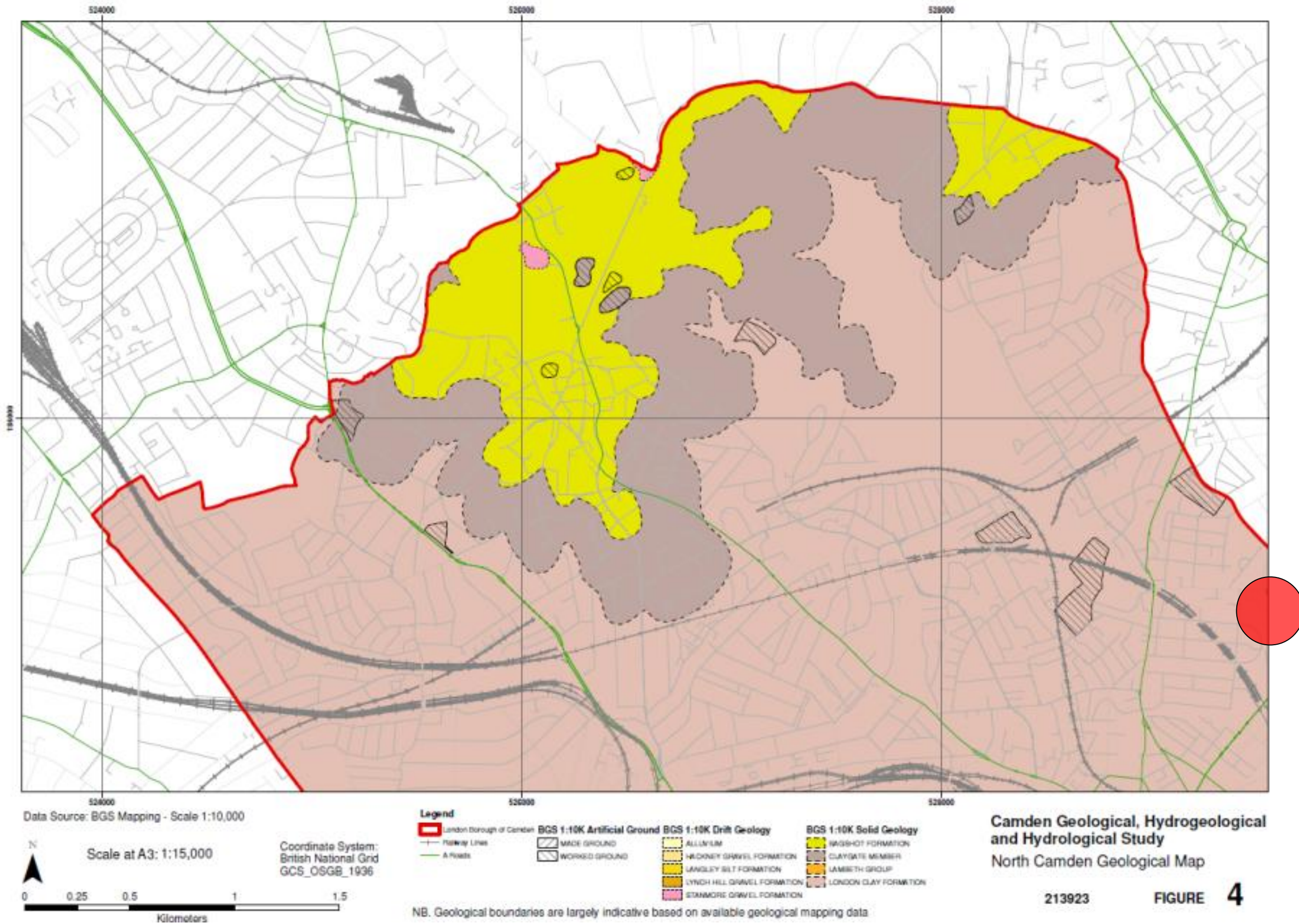

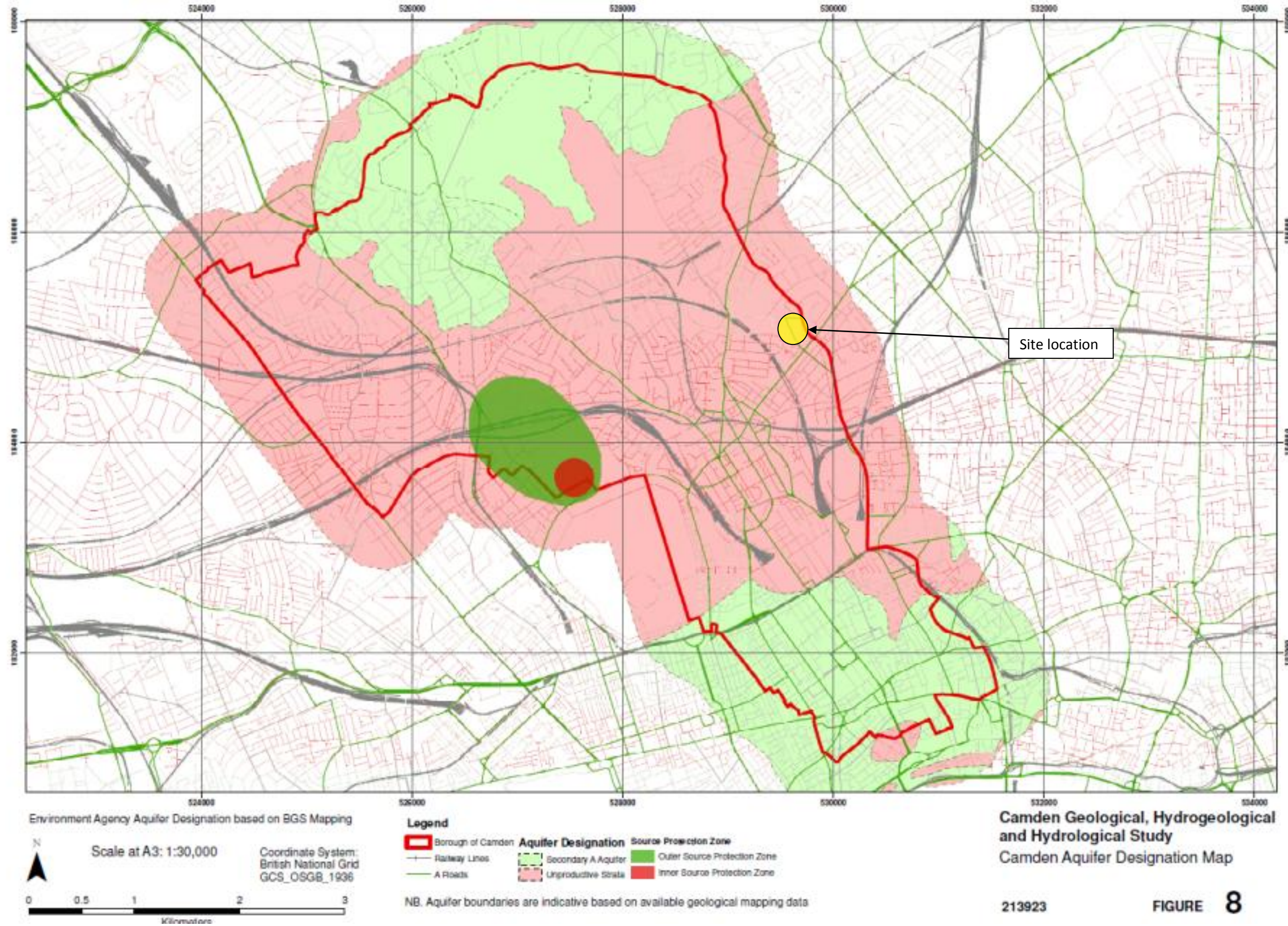

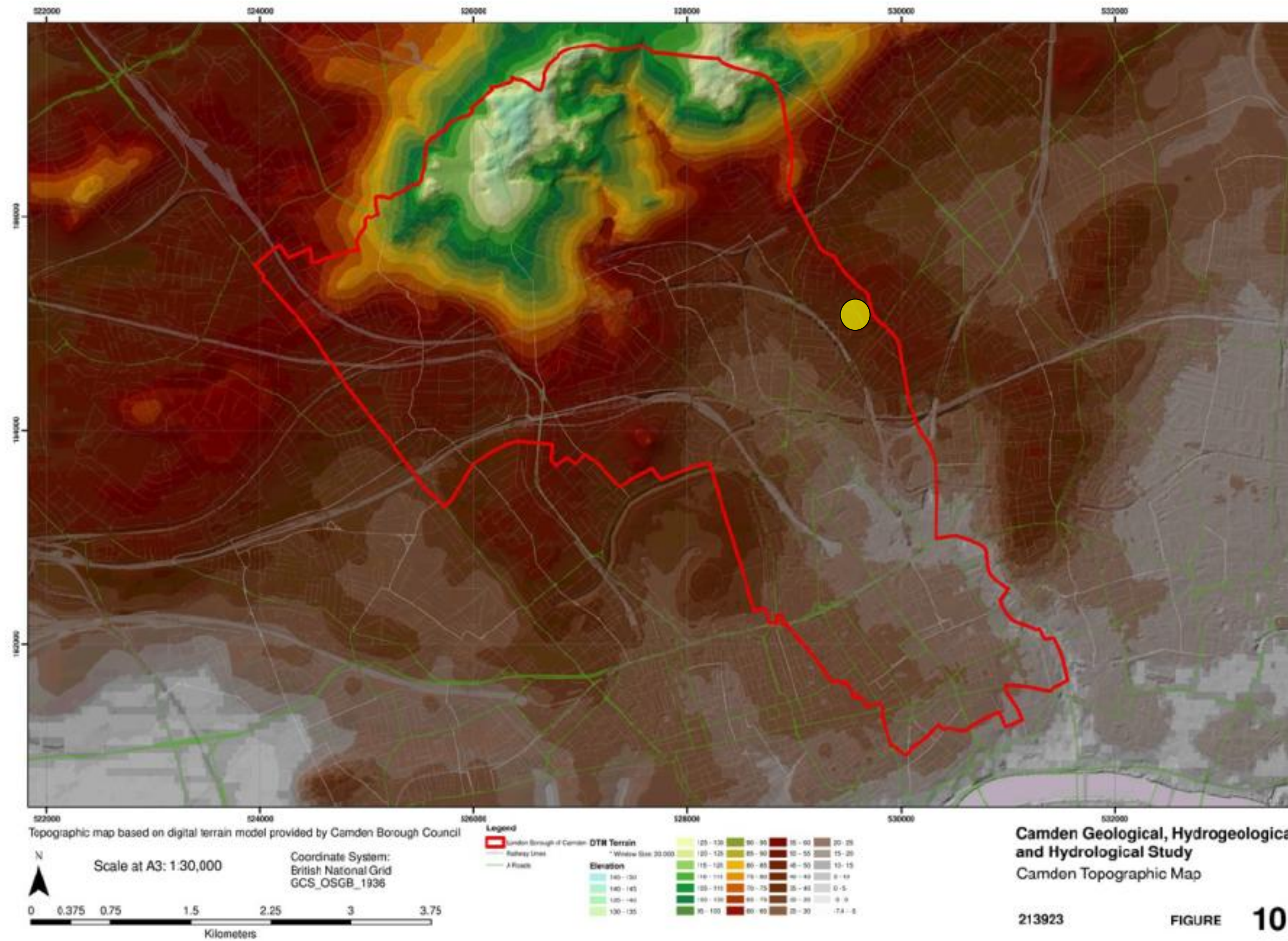

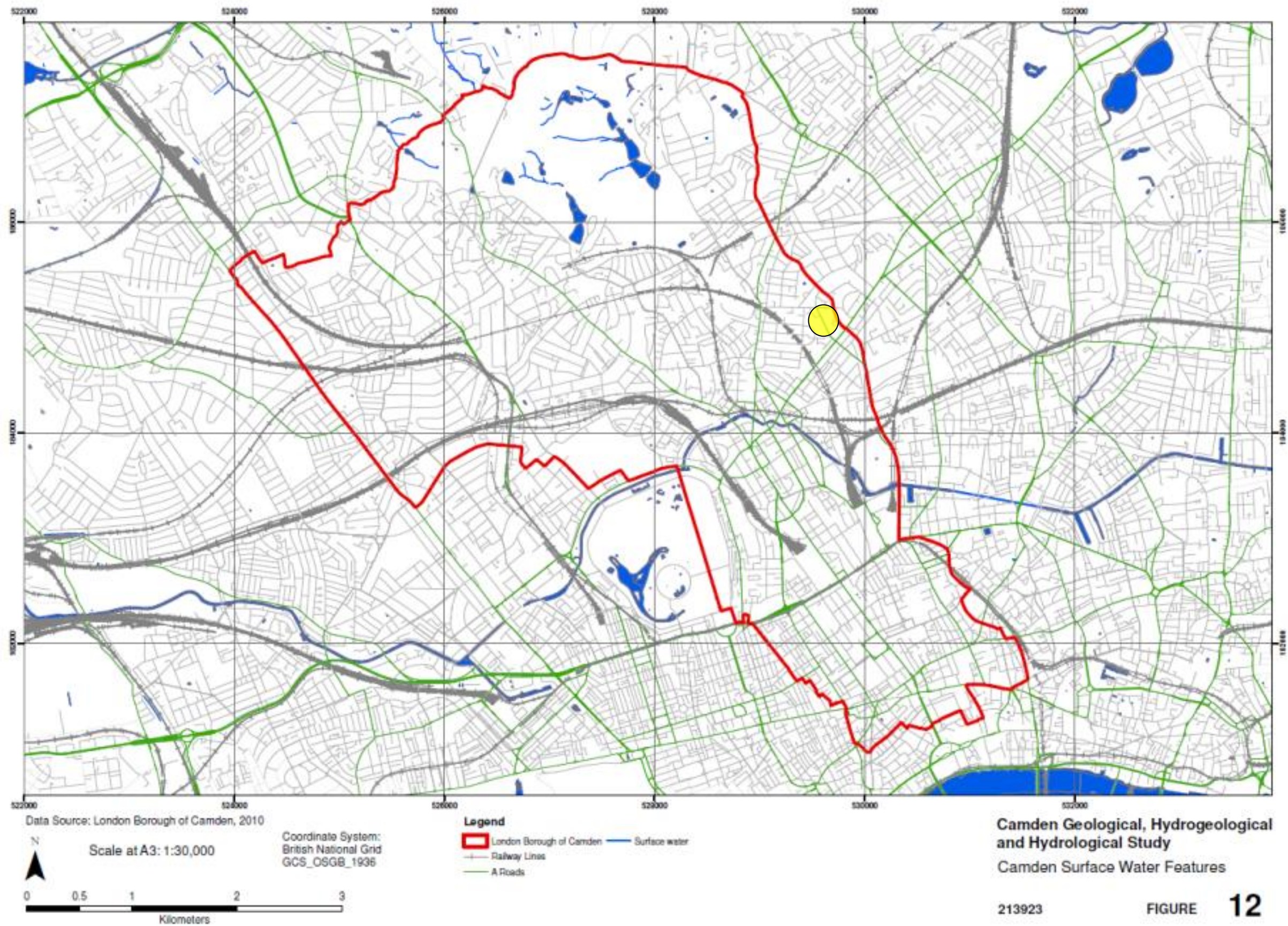

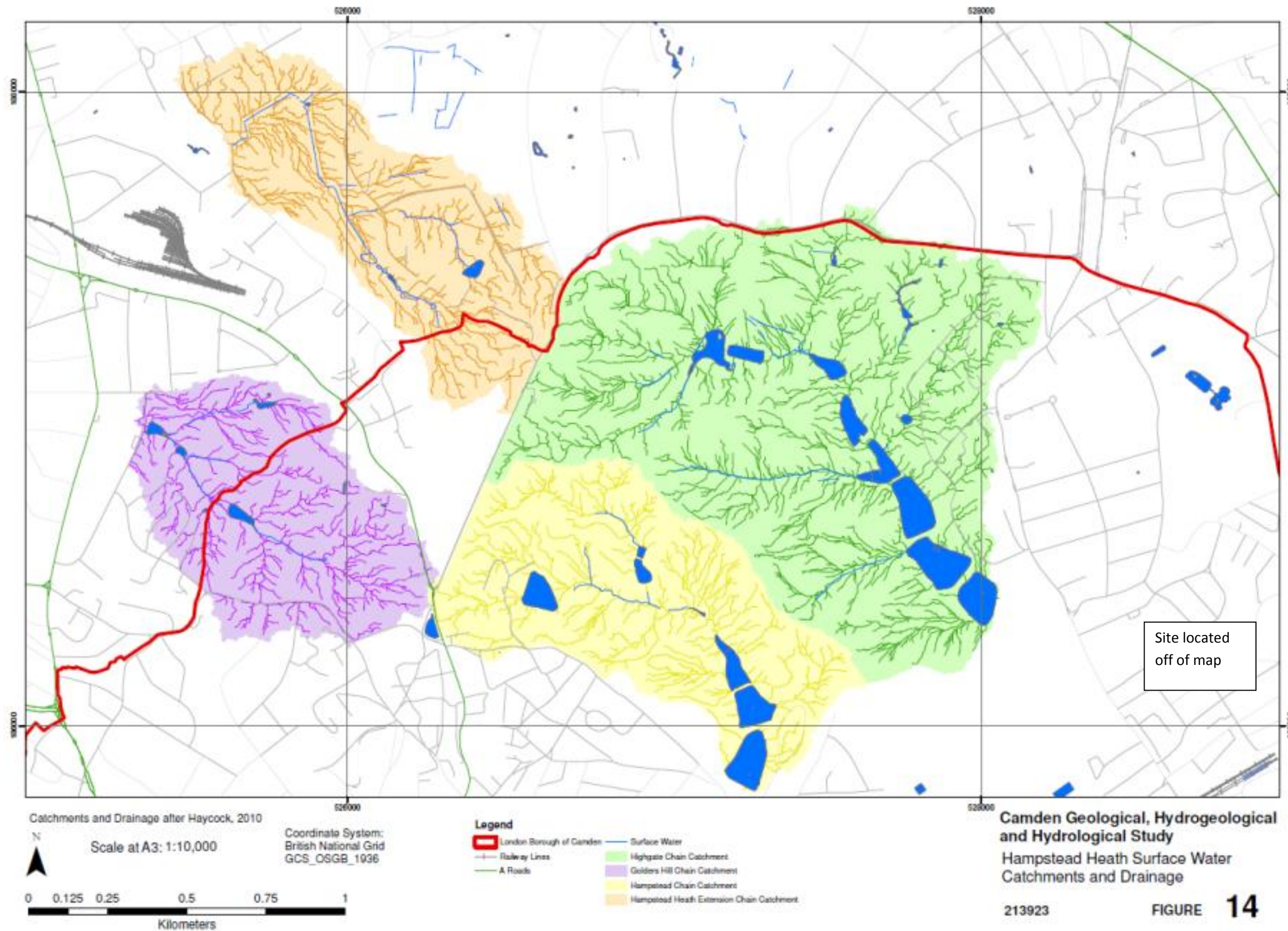

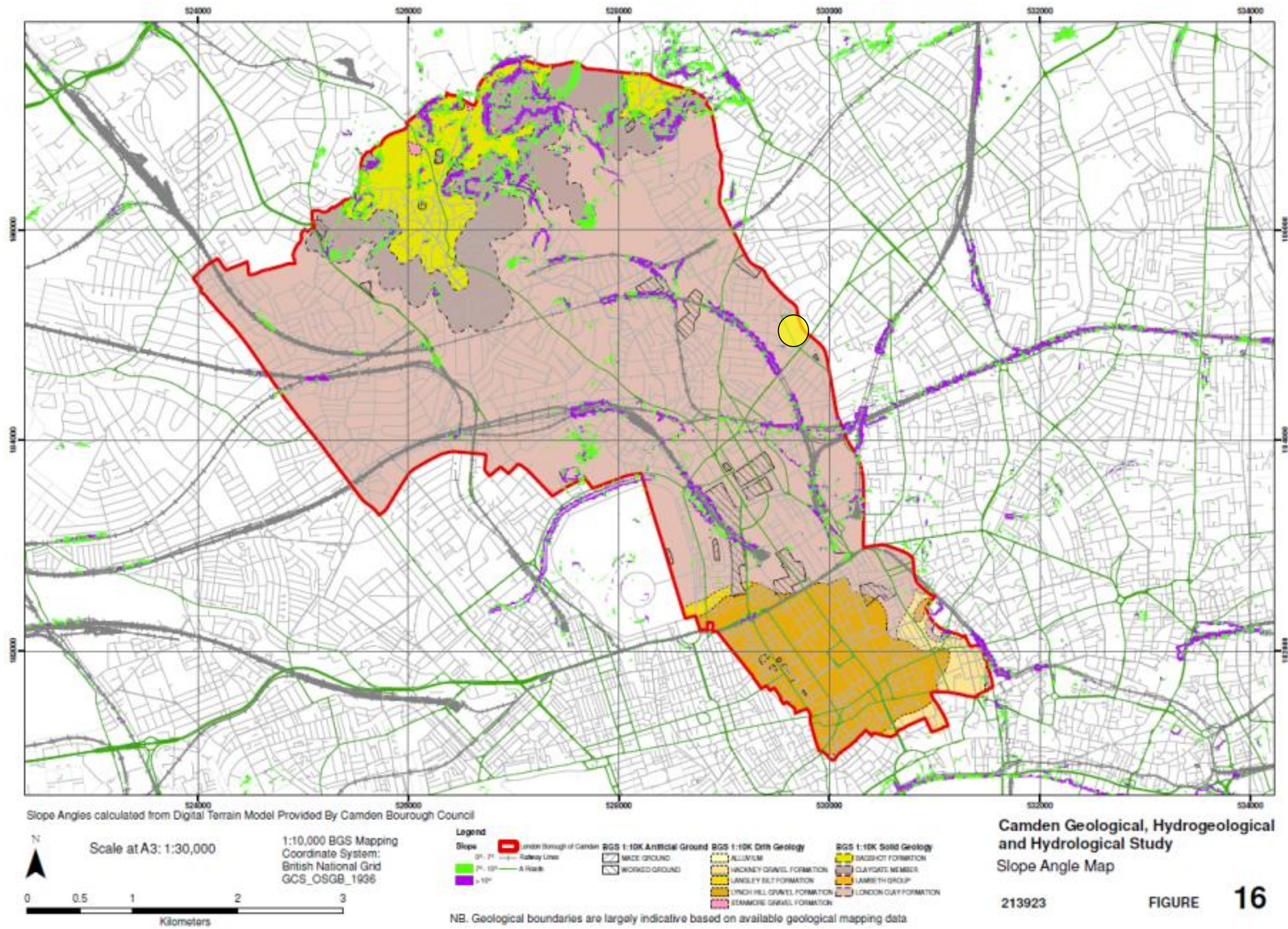

Appendix E

Example Damage Category Calculation

Stage 1

Ground movements behind the retaining wall should be estimated as described in Section 2.5.2 assuming greenfield conditions, ie ignoring the presence of the building or utility and the ground above foundation level. Contours of ground surface movements should be drawn and a zone of influence established based on specified settlement and distortion criteria. All structures and utilities within the zone of influence should be identified.

Stage 2

A condition survey should be carried out on all structures and utilities within the zone of influence before starting work on site. The structure or utility should be assumed to follow the ground (ie it has negligible stiffness), so the distortions and consequently the strains in the structure or utility can be calculated. The method of damage assessment should adopt the limiting tensile strain approach as described by Burland *et al* (1977), Boscardin and Cording (1989) and Burland (2001); see Table 2.5 and Figure 2.18.

Table 2.5 Classification of visible damage to walls (after Burland *et al*, 1977, Boscardin and Cording, 1989; and Burland, 2001)

Category of damage	Description of typical damage (ease of repair is underlined>	Approximate crack width (mm)	Limiting tensile strain ϵ_{lim} (per cent)
0 Negligible	Hairline cracks of less than about 0.1 mm are classed as negligible.	< 0.1	0.0-0.05
1 Very slight	<u>Fine cracks that can easily be treated during normal decoration.</u> Perhaps isolated slight fracture in building. Cracks in external brickwork visible on inspection.	< 1	0.05-0.075
2 Slight	<u>Cracks easily filled. Redecoration probably required.</u> Several slight fractures showing inside of building. Cracks are visible externally and <u>some repointing may be required externally</u> to ensure weathertightness. Doors and windows may stick slightly.	< 5	0.075-0.15
3 Moderate	<u>The cracks require some opening up and can be patched by a mason. Recurrent cracks can be masked by suitable linings. Repointing of external brickwork and possibly a small amount of brickwork to be replaced.</u> Doors and windows sticking. Service pipes may fracture. Weathertightness often impaired.	5-15 or a number of cracks > 3.	0.15-0.3
4 Severe	<u>Extensive repair work involving breaking-out and replacing sections of walls, especially over doors and windows.</u> Windows and frames distorted, floor sloping noticeably. Walls leaning or bulging noticeably, some loss of bearing in beams. Service pipes disrupted.	15-25 but also depends on number of cracks	> 0.3
5 Very severe	<u>This requires a major repair involving partial or complete rebuilding.</u> Beams lose bearings, walls lean badly and require shoring. Windows broken with distortion. Danger of instability.	usually > 25 but depends on number of cracks.	

Notes

- In assessing the degree of damage, account must be taken of its location in the building or structure.
- Crack width is only one aspect of damage and should not be used on its own as a direct measure of it.

Job 14286 - Admiral Mann PH

Date Feb '15 Page

Title Monitoring and Damage Categories

By EMK Chkd

Title to Identify Wall

Longitudinal Length, $L_1 = 10.0$ m
 Transverse Length, $L_2 = 7.0$ m
 Height, $H = 12.0$ m

→ NEIGHBOURING BUILDING DIMENSIONS (POST DEVELOPMENT).
 → $L/H = 0.58$

Damage Category 0 $\epsilon_{lim} = 0.050$ %

$\epsilon_h/\epsilon_{lim}$	ϵ_h (%)	δ_h (mm)	$(\Delta/L)/\epsilon_{lim}$	Δ/L	Δ (mm)
0	0	0	1	5.0E-04	5.0
0.2	0.01	1	0.91	4.6E-04	4.6
0.4	0.02	2	0.8	4.0E-04	4.0
0.6	0.03	3	0.64	3.2E-04	3.2
0.8	0.04	4	0.42	2.1E-04	2.1
1	0.05	5	0	0.0E+00	0.0

Damage Category 1 $\epsilon_{lim} = 0.075$ %

$\epsilon_h/\epsilon_{lim}$	ϵ_h (%)	δ_h (mm)	$(\Delta/L)/\epsilon_{lim}$	Δ/L	Δ (mm)
0	0	0	1	7.5E-04	7.5
0.2	0.015	2	0.91	6.8E-04	6.8
0.4	0.03	3	0.8	6.0E-04	6.0
0.6	0.045	5	0.64	4.8E-04	4.8
0.8	0.06	6	0.42	3.2E-04	3.2
1	0.075	8	0	0.0E+00	0.0

Damage Category 2 $\epsilon_{lim} = 0.150$ %

$\epsilon_h/\epsilon_{lim}$	ϵ_h (%)	δ_h (mm)	$(\Delta/L)/\epsilon_{lim}$	Δ/L	Δ (mm)
0	0	0	1	1.5E-03	15.0
0.2	0.03	3	0.91	1.4E-03	13.7
0.4	0.06	6	0.8	1.2E-03	12.0
0.6	0.09	9	0.64	9.6E-04	9.6
0.8	0.12	12	0.42	6.3E-04	6.3
1	0.15	15	0	0.0E+00	0.0

Job 14286 - Admiral Mann PH

Date Feb '15 Page

Title Monitoring and Damage Categories

By EMK Chkd

Plot Showing Upper Bound Limit of Acceptable Movement

APPROXIMATE POSITION DUE TO WALL MOVEMENTS.

- ANTICIPATED VERTICAL MOVEMENT = 3-4mm.
- ANTICIPATED HORIZONTAL MOVEMENT = 3-4mm.

⊗ GRAPH ABOVE SHOWS THAT ANTICIPATED MOVEMENT FALLS WITHIN DAMAGE CATEGORY 2 LIMITS.

Appendix G

Copy of Southern Testing Site Investigation Interpretive Report. Ref J12113, February 2015.

Site Investigation Report



Desk Studies | Risk Assessments | Site Investigations | Geotechnical | Contamination Investigations | Remediation Design and Validation

Site: Admiral Mann Public House, Hargrave Place, N7 0BP

Client: Woodham Properties Limited

Report Date: February 2015

Project Reference: J12113

Southern Testing Head Office
East Grinstead
Tel: 01342 333100
enquiries@southerntesting.co.uk

ST Consult Midlands
Northampton
Tel: 01604 500020
creaton@stconsult.co.uk

ST Consult North West
Warrington
Tel: 01925 661 700
warrington@stconsult.co.uk

ST Consult South West
Swindon
Tel: 01793 441 522
swindon@stconsult.co.uk



FS 29280

EMS 506775

OHS 506776



SUMMARY

The site, currently comprises the existing public house (The Admiral Mann) No 9 and 9a Hargrave Place, London, N7 0BP.

For descriptive purposes only the existing Public House building may be subdivided into three adjoining sections. The northern section comprises a three storey building with a cellar area beneath. The adjoining "middle" section to the south is single storey with a flat roof above and the southernmost section (No 9a Hargrave Place) is 2 storeys. The upper floors of the two and three storey sections are currently used as residential accommodation.

On the northern three storey section it is proposed to deepen the existing cellar floor area by some 600-700mm and to erect a Mansard Roof extension. It is also proposed to extend the middle single and southern two storey sections with additional floors.

Geological records indicate the site to be underlain by London Clay

A single phase of intrusive investigation was carried out.

The soils encountered comprised up to 0.8m of Made Ground over London Clay. The London Clay was proved to a depth of 3.0m below the existing basement and ground floor slabs.

During the course of the investigation groundwater was encountered in three of the four shallow inspection pits carried out within the cellar area (TP1, TP2 & TP4) and also within window sample hole WS2 which was carried out from the base of TP1. However, while siteworks were in progress no other groundwater entries were noted in the other trial pits and window sample holes carried. The noted groundwater entries in TP1/WS2, TP2 and TP4 are considered to be perched groundwater sources from around the existing foundation construction.

In the subsequent groundwater monitoring visits of the standpipes installed groundwater levels were measured between 0.21m (bgl) and 2.91m (bgl) within WS1 & WS2, which were carried out within the cellar area. The monitoring well installed in WS3 remained dry to the base of the 3m deep installation.

The sulphate content of the fill and natural soil was found to fall within Class DS-3. The ACEC classification for the site is AC-2s.

NHBC High Volume Change Potential precautions shall apply.

The proposed development includes a basement structure which is to be constructed using conventional underpinning methods and parameters for retaining wall design are given.

The design of the new basement foundation system should take into account the nature of the existing/adjacent foundations and their condition.

The results of the contamination testing, which were carried out, mainly for waste classification purposes, but also to assist with the site health and safety assessment, are also included. Soil analysis has indicated that the Made Ground and underlying natural soils tested were largely free from significant contamination, other than some fairly minor lead impact of the Made Ground. In our experience, this is typical for fill material in London. The results should be sent to the groundworks contractor, for their health and safety appraisal, and the prospective tip, for waste classification purposes.

A discovery strategy should be put in place to deal with any significant contamination that comes to light during the development work.

The site investigation was conducted and this report has been prepared for the sole internal use and reliance of Woodham Properties Limited and their appointed Engineers. This report shall not be relied upon or transferred to any other parties without the express written authorization of Southern Testing Laboratories Ltd. If an unauthorised third party comes into possession of this report they rely on it at their peril and the authors owe them no duty of care and skill.

The findings and opinions conveyed via this Site Investigation Report are based on information obtained from a variety of sources as detailed within this report, and which Southern Testing Laboratories Ltd believes are reliable. Nevertheless, Southern Testing Laboratories Ltd cannot and does not guarantee the authenticity or reliability of the information it has obtained from others.

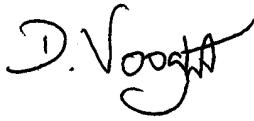

D. Vooght MSc
(Countersigned)



J.N. Race MSc CGeol



S. Marshall BSc FGS
(Signed)

For and on behalf of Southern Testing Laboratories Limited

STL: J12133
3 February 2015

TABLE OF CONTENTS

A	INTRODUCTION.....	1
1	AUTHORITY.....	1
2	LOCATION.....	1
3	PROPOSED CONSTRUCTION	1
4	OBJECT.....	1
5	SCOPE.....	1
B	DESK STUDY & WALKOVER SURVEY.....	2
6	DESK STUDY.....	2
7	WALKOVER SURVEY.....	4
C	SITE INVESTIGATION	4
11	METHOD.....	4
12	WEATHER CONDITIONS	5
13	SOILS AS FOUND.....	5
14	GROUNDWATER STRIKES	5
D	FIELD TESTING AND SAMPLING.....	6
E	GEOTECHNICAL LABORATORY TESTS	6
F	DISCUSSION OF GEOTECHNICAL TEST RESULTS AND RECOMMENDATIONS.....	6
15	SOIL CLASSIFICATION AND PROPERTIES	6
16	SWELLING AND SHRINKAGE	7
17	GROUNDWATER LEVELS AND HYDROGEOLOGY.....	7
18	SULPHATES AND ACIDITY.....	8
19	BEARING CAPACITY	9
20	HEAVE	9
21	BASEMENT CONSTRUCTION.....	10
22	EXCAVATIONS AND TRENCHING	10
G	LAND QUALITY.....	10
23	ANALYTICAL FRAMEWORK.....	10
24	SITE INVESTIGATION – SOIL.....	11
25	SUMMARY OF IDENTIFIED CONTAMINATION.....	14
26	RECOMMENDATIONS.....	14
27	DISCUSSION AND CONCLUSIONS.....	14
28	GENERAL GUIDANCE	15

APPENDIX A	Site Plans and Exploratory Hole Logs
APPENDIX B	Field Sampling and in-situ Test Methods & Results
APPENDIX C	Geotechnical Laboratory Test Methods & Results
APPENDIX D	Contamination Laboratory Test Results
APPENDIX E	Bomb Map
APPENDIX F	PDISP Output for heave displacements

A INTRODUCTION

1 Authority

Our authority for carrying out this work is contained in a completed Southern Testing Project Order form dated 02/02/2015 and signed by Mr J Moore of Moreland & Co.

2 Location

The site is located approximately 1.0km north east of Camden Road Station. The approximate National Grid Reference of the site is TQ 297 850.

3 Proposed Construction

On the northern three storey section of the current building it is proposed to deepen the existing cellar floor area by some 600-700mm and also to erect a Mansard Roof extension. It is also proposed to extend the "middle" single and southern two storey sections of the building to be extended with an additional upper floor.

For the purposes of the contamination risk assessment, the proposed development land use is classified as a mixture of **Residential (without plant uptake) and Commercial/Industrial (CLEA model¹/C4SL report²)**. For the purpose of this risk assessment a classification of **Residential (without plant uptake) has been adopted**. The gas sensitivity of the site is rated as High (CIRIA C665³).

4 Object

The object of the investigation was to assess foundation bearing conditions and other soil parameters relevant to the proposed development.

5 Scope

This report presents our desk study findings, exploratory hole logs and test results and our interpretation of these data.

As with any site there may be differences in soil conditions between exploratory hole positions.

This report is not an engineering design and the figures and calculations contained in the report should be used by the Engineer, taking note that variations will apply, according to variations in design loading, in techniques used, and in site conditions. Our figures therefore should not supersede the Engineer's design.

The findings and opinions conveyed via this Site Investigation Report are based on information obtained from a variety of sources as detailed within this report, and which Southern Testing Laboratories Ltd believes are reliable. Nevertheless, Southern Testing Laboratories Ltd cannot and does not guarantee the authenticity or reliability of the information it has obtained from others.

¹ Environment Agency Publication SC050021/SR3 'Updated technical background to the CLEA Model' (2009).

² SP1010 Development of Category 4 Screening Levels DEFRA (2014)

³ CIRIA C665 (2006) Assessing risks posed by hazardous ground gases to buildings.

The site investigation was conducted and this report has been prepared for the sole internal use and reliance of Woodham Properties Limited and their appointed Engineers. This report shall not be relied upon or transferred to any other parties without the express written authorization of Southern Testing Laboratories Ltd. If an unauthorised third party comes into possession of this report they rely on it at their peril and the authors owe them no duty of care and skill.

The recommendations contained in this report may not be appropriate to alternative development schemes. The contamination screening values used are valid at the time of writing but may be subject to change and any such changes will have implications for the assessments based on them. Their validity should be confirmed at the time of site development.

B DESK STUDY & WALKOVER SURVEY

6 Desk Study

A limited geotechnical desk study has been carried out. Reference has been made to the following information sources.

- Geological Maps
- Environment Agency website
- Bomb Maps
- Historical Map Search
- BRE Radon Atlas⁴

6.1 Geology

The British Geological Survey Map of the area (No. 256-North London) indicates that the site geology consists of London Clay.

London Clay

London Clay is a well-known stiff (high strength) blue-grey, fissured clay, which weathers to a brown colour near the surface. It contains thin layers of nodular calcareous mudstone - "claystone" - from place to place, and crystals of water clear calcium sulphate (selenite) are common.

6.2 Hydrology and Hydrogeology

Data from the Environment Agency and other information relating to controlled waters is summarised below.

Data		Remarks
Aquifer Designation	Superficial Deposits	There are no superficial deposits mapped onsite.
	Bedrock	Unproductive Strata (London Clay)- deposits with low permeability that have a negligible significance for water supply or river base flow.

⁴ BR 211 (2007) 'Radon: guidance on protective measures for new buildings'

Data	Remarks
Source Protection Zones	The site is not located within a Source Protection Zone.
Surface Water Features	Grand Union Canal is located approximately 1.1km to the south west. The Hampstead Heath Ponds/Highgate ponds are located approximately 2.3km to the north west.
Watercourses, well (used/disused) or potential spring lines	The nearest water course shown on the Camden Plan of Watercourses (Source Lost Rivers of London) shows the River Fleet approximately 1.1km to the west. Given the geology of the area (London Clay) the potential presence of spring lines are negligible.
Fluvial Flood Risk	On the basis of the information given on the EA website (January 2015) the site is not located within an area at risk of flooding from fluvial sources.
Surface Water Floor Risk	The "Risk of Flooding from Surface Water" mapping on the Environment Agency website (January 2015) shows the site to be within an area of Very Low Risk. Very Low Risk means that each year, this area has a chance of flooding is less than 1 in 1000 (0.1%).
Reservoir Flood Risk	On the basis of the information given on the EA website (February 2015) the site is not located within an area of potential risk of flooding from reservoirs.

6.3 Bomb Map

The published bomb map for the area, taken from the London County Council Bomb Damage Maps (1939-1945), shows that the site suffered blast damage, minor in nature (shown in yellow). The map also shows a number building to the north suffered damage beyond repair (shown in purple) with one building suffering total destruction (shown in black), a number of areas to the east and west of the site are shown as being clearance areas (shown in light green) please refer to Figure A presented within Appendix E.

6.4 Historical Maps

An inspection of historical maps freely available on the internet was carried out. The earliest map available, 1850-1851, does not show any of the existing properties on James Street/Hargrave Place, but does show the basic road lines including Hargrave Place. The road now called Hargrave Place is labelled as James Street with Hargrave Place being present along the western site boundary. The next map dated 1873 shows the public house, along with a number of other properties along James Street/Hargrave Place. Between the 1873 mapping and 1953-1954 mapping there appears to be very little change. The 1953-1954 mapping still shows the public house, but the buildings to the east of the site have been removed and mapped as a ruin. James Street has been renamed Hargrave Place, with the road layout appearing similar to the current day mapping, with the omission of Brecon Mews to the south of the site. By the 1956-1969 mapping the site adjacent to the east of the site is no longer labelled as a ruin.

6.5 Radon Risk

With reference to BRE guidance: no radon protection is required on this site.

7 Walkover Survey

A walkover survey was carried out on 13th January 2015.

7.1 General Description and Boundaries

The existing Public House building may be subdivided into three adjoining sections. The northern section comprises a three storey building with a cellar area beneath. The adjoining "middle" section to the south is single storey with a flat roof above and the southernmost section (No 9a Hargrave Place) is 2 storeys. The upper floors of the two and three storey sections are currently used as residential accommodation. The structure is of a masonry brick construction.

The site is located on Hargrave Place which is a small cul-del-sac leading off Brecknock Road. Hargrave Place terminates at a gated entrance to Brecon Mews, an estate of 3-storey town houses which bounds the site on its southern side. A narrow alleyway marks the eastern site boundary with a single storey industrial warehouse type property beyond. On the western site boundary is the highway linking Hargrave Place with Brecon Mews, beyond which is a brick retaining wall which steps down by approximately 1.5 to 1.8m towards an estate of local authority 4-storey flats.

The local/regional topography in this instance comprises slight falls to the south east and west which combines into an overall local fall towards the south west at approximately 2°.

At the time of the investigation no significant vegetation was present on the site itself. A laurel bush is located on the southern rear boundary within the Brecon Mews development together with single conifer by the entrance gates/rear of the boundary wall to Brecon Mews approximately 5-6m from the southern site boundary. In addition a row of mature deciduous trees are present approximately 15m from the site to the north within the grassed landscaped to an estate of local authority flats.

The majority of the neighbouring properties appear to be residential houses and local authority flats. A number of commercial/retail properties are present to the east of the site along Brecknock Road.

C SITE INVESTIGATION

11 Method

The strategy adopted for the intrusive investigation comprised the following:

- 2 No 3.0m deep boreholes were drilled within the existing basement area using hand held window sampler equipment (WS1& WS2).
- 1 No. 3.0m deep borehole was drilled from ground level using hand held window sampler equipment (WS3).
- Groundwater monitoring wells were installed within WS1, WS2 & WS3 for groundwater monitoring purposes.
- A series of 7 foundation inspection pits (TP1 – 7) were excavated by hand to establish existing foundation conditions.

Exploratory hole locations are shown in Figure 1 in Appendix A.

12 Weather Conditions

The fieldwork was carried out on 13th January 2015 at which time the weather was generally overcast with occasional rain showers. The preceding month of December 2014 was drier on average in the southeast of England, with approximately 67% of the normal rainfall. November was wetter than average with approximately 160% of the normal and October was generally wetter than average with approximately 120% of the normal rainfall.

13 Soils as Found

The soils encountered are described in detail in the attached exploratory hole logs (Appendix A), but in general within the window sample holes carried out the soils from the basement floor slab level (approximately 1.6m bgl) and the existing ground level comprised a Made Ground, over London Clay. A summary is given below.

Depth to Base (m)*	Soil Type	Description
GL-0.13/0.15	Concrete	Concrete
0.4-0.8	Made Ground	Grey brown to orange brown, clayey, fine to coarse, SAND/sandy CLAY, with occasional to frequent fragments of brick, concrete, slate, glass, ash and flint gravel (MADE GROUND).
0.55	Made Ground <i>(WS2 only)</i>	Dark grey to black, organic, sandy, CLAY, with occasional fragments of wood, ash and flint gravel (MADE GROUND).
3.0+	London Clay	Firm to stiff, high to very high strength, brown to orange brown, CLAY, with occasional selenite crystals.

*It should be noted that WS1 & WS2 were drilled within the existing basement area (approximately 1.6m bgl) and that WS3 was drilled from ground level.

14 Groundwater Strikes

Water was struck in the exploratory holes as follows:

TP	Water Strikes
TP1	Water encountered at 0.35m rising to 0.27m below basement floor level, 15 minutes after completion.
TP2	Water encountered at 0.42 rising to 0.36m below basement floor level, 10 minutes after completion.
WS2	Standing water level at 0.35m on completion (believed to be inflow from TP1).

TP	Water Strikes
TP4	Standing water level 0.30m rising to 0.23m below basement floor level, 15 minutes after completion.

The site was revisited on two separate occasions to carry out measurements of the standing water levels within the three standpipes installed in the window sample boreholes. The reader is referred to Section 17 for the results of these measurements.

D FIELD TESTING AND SAMPLING

The following in-situ test and sampling methods were employed. Descriptions are given in Appendix B together with the test results.

- Disturbed Samples
- Hand Penetrometer Tests

E GEOTECHNICAL LABORATORY TESTS

The following tests were carried out on selected samples. Test method references and results are given in Appendix C.

- Atterberg Limit Tests
- Moisture Content
- Soluble Sulphate and pH

F DISCUSSION OF GEOTECHNICAL TEST RESULTS AND RECOMMENDATIONS

15 Soil Classification and Properties

Soil Type	Depth	Compressibility	VCP	Permeability	Frost Susceptible	CBR	Remarks
Made Ground	GL to 0.5/0.8m	N/A	N/A	Low but seepages from more permeable horizons are anticipated	Yes	N/A	Not suitable for foundations
London Clay	0.5/0.8 to 3.0	Medium	High	Very low/impermeable, but seepages from fissures can occur	No	Poor	

16 Swelling and Shrinkage

Shrinkable soils are subject to changes in volume as their moisture content is altered. Soil moisture contents vary from season to season and can be influenced by a number of factors including the action of roots. The resulting shrinkage or swelling of the soil can cause subsidence or heave damage to foundations, the structures they support and services.

The designer should be aware that precautions regarding swelling and shrinkage are applicable. NHBC precautions provide a helpful guide with respect to minimum foundation depths and deepening particularly within the zone of influence of trees.

Assessment of foundation depths should take into account not only those, trees which have or are to be removed, but also those remaining or proposed which may be allowed to reach maturity.

All four of the plasticity tests carried out classified the natural London Clay soils as being NHBC HIGH Volume Change Potential (VCP). Therefore we would recommend that NHBC High Volume Change Potential (VCP) should be adopted for a general site classification with regards to the London Clay Soils on site.

However, given the depth of the proposed foundations to the cellar area, which are expected to be in the region of 2.5-2.6m BGL, and the distance of the nearest trees to the north, no specific precautions are considered necessary with respect to further foundation deepening of the basement foundations. Where shallower or existing foundations are required/present, then NHBC High Volume Change precautions would be applicable.

17 Groundwater Levels and Hydrogeology

Groundwater levels vary considerably from season to season and year to year, often rising close to the ground surface in wet or winter weather, and falling in periods of drought. Long-term monitoring from boreholes or standpipes is required to assess the ground water regime and this was not possible during the course of this site investigation.

During the course of the investigation groundwater was encountered in three of the four shallow inspection pits carried out within the cellar area (TP1, TP2 & TP4) and also within window sample hole (WS2) which was carried out from the base of TP1. However, while siteworks were in progress no other groundwater entries were noted in the other trial pits and window sample holes carried out. The noted groundwater entries in TP1/WS2, TP2 and TP4 are considered to be perched groundwater sources from around the existing foundation construction.

The standing water levels from the groundwater monitoring visits to date are shown in the table below.

Hole ID	Date	Standing water level (m bgl)
WS1*	13/01/2015 (during site work)	Dry
	16/01/2015	2.96
	23/01/2014	2.91
WS2*	13/01/2015 (during site work)	0.35

	16/01/2015	0.21
	23/01/2014	0.25
WS3	13/01/2015 (during site work)	Dry
	16/01/2015	Dry
	23/01/2014	Dry

*It should be noted that WS1 & WS2 were drilled within the existing cellar area (approximately 1.6m bgl) and that WS3 was drilled from ground level.

On the basis of the measurements to date, groundwater ingress is not expected to be a significant problem in terms of dewatering issues etc during construction. However, allowances for some dewatering, should be made from perched sources e.g. within the made ground/base of existing foundations, in the form of intermittent pumping from strategically placed collector sumps.

For the longer term condition, seepage entries from fissure flow within the clays and any perched water from within the overlying made ground should be allowed for in the design of the basement area e.g. provision of waterproofing measures, and also for hydrostatic uplift of the basement floor slab.

Published data for the permeability of the London Clay indicates the horizontal permeability to generally range between 1×10^{-9} m/s and 1×10^{-14} m/s, with an even lower vertical permeability. Accordingly, the groundwater flow rate is anticipated to be extremely low to negligible.

Any groundwater flows that take place will likely follow the local/regional topography which in this instance comprises slight falls to the south east and west which combines into an overall local fall towards the south west. Given the very slight falls in the local/regional topography, hence negligible hydraulic gradient, and the very low/impermeable nature of the underlying clay materials, there is negligible risk of the proposed basement walls causing a "damming effect" or mounding of water on the upstream faces.

Given the above observations/comments, it is concluded that the proposed development will not result in any specific issues relating to the hydrogeology and hydrology of the site.

In terms of the potential cumulative effects on the groundwater environment in the local area, i.e. the effects of the proposed deepening of the existing cellar by only 600-700mm, and should other future basements be granted beneath adjacent properties, the combination of the overall regional and local topographic falls of the area (hence negligible to low hydraulic gradients), and the very low/impermeable nature of the underlying London Clay, any resulting increases in groundwater levels within the area (locally or regionally) will be negligible.

18 Sulphates and Acidity

The measured pH of the made ground and natural clay soils tested ranged between 7.6 and 10.2.

The soluble sulphate levels recorded within the made ground was between 100mg/l & 560mg/l and within the underlying natural clay soils soluble sulphate concentrations ranged between 125mg/l and 2496mg/l.

On the basis of the above measurements, we would recommend that BRE Class DS-3 precautions should be adopted for subsurface concrete together with an ACEC class of AC-2s.

19 Bearing Capacity

We understand that it is proposed to construct the basement, possibly using conventional underpinning methods.

Where it is necessary to construct spread foundations or bases to retaining walls/underpinned sections as part of the proposed works, all foundations should clearly penetrate any made ground and be formed on the underlying natural High Strength Clay materials. For foundations formed on these materials, an allowable bearing capacity of 125kPa may be adopted.

20 Heave

Due to stress relief following the removal of the existing soils to form the basement structure, both immediate (undrained) and long term (drained) heave displacements can be expected to occur in the underlying London Clay.

The immediate (undrained) heave displacements will occur as excavation of the basement takes place and before the construction of basement elements e.g. slabs etc. Accordingly, only the long term (drained) heave displacements will need to be catered for in design, to overcome the problem of uplift pressures forming. This is normally overcome by installing appropriate void forming materials beneath the basement elements.

For the analysis of heave movements, the following stiffness parameters after Burland and Kalra (1986)⁵ are suggested for the London Clay:

$$\text{Undrained Young's Modulus } (E_u) = (10+5.2z) \text{ (MN/m}^2\text{)}$$

$$\text{Undrained Poisson Ratio } (v_u) = 0.5$$

$$\text{Drained Young's Modulus } (E_d) = (7.5+3.9z) \text{ (MN/m}^2\text{)}$$

$$\text{Drained Poisson Ratio } (v_d) = 0.2$$

Where z (m) is taken from the surface of the London Clay

It is proposed to reduce ground levels in the existing lower ground floor by between 600mm to 700mm; an analysis of heave displacements has been carried out using PDisp and the above parameters.

The results of the analysis are given in Appendix F. Figure U1 relates to the immediate (undrained) heave displacements and Figure V1 to the total long term (drained) heave displacements (which includes the immediate heave displacements).

⁵ Burland J.B. and Kalra J.C. (1986) Queen Elizabeth Conference Centre: geotechnical aspects, Proc. Inst. Civ. Engrs, Part 1,80,1479-1503

The maximum undrained heave displacement (2.5mm) occurs beneath the central point of the proposed basement floor area. The total long term drained heave movement (which includes the initial undrained heave movement) occurs at the same point and is 4mm.

21 Basement Construction

Based on the findings of the boreholes (WS1, WS2 & WS3) and the soil types encountered, the following soil parameters are suggested for design of retaining walls:

Soil Type	Bulk density γ_b (kN/m ³)	Undrained Shear Strength (Temporary Condition)	Long Term Drained Condition	
			c' (kN/m ²)	ϕ^o
Made Ground	19	n/a	0	25
London Clay	20	Cu=60kPa	0	25

22 Excavations and Trenching

Statutory lateral earth support will be required in all excavations where men must work. Instability of the sides of any excavations carried out must be expected. Accordingly, measures should be taken at all times to ensure that excavations undertaken during underpinning operations are adequately supported.

Given the presence of the existing/adjacent foundations, close attention in design of temporary and permanent propping is required of the underpinning works at all times to prevent settlement or excessive lateral yielding of the excavation/foundations.

Providing good levels of construction are employed and close attention is taken to temporary/permanent propping measures as noted above, it is unlikely that the proposed construction will result in any specific issues relating to land stability issues, however monitoring of the adjacent properties are likely to be required while the works are in progress..

Allowances should be made for breaking out subsurface obstructions, e.g. old footings, drain runs etc. associated with the existing development on the site.

G LAND QUALITY

23 Analytical Framework

To assist with waste classification, a number of representative samples were analysed for a range of general potential contaminants.

There is no single methodology that covers all the various aspects of the assessment of potentially contaminated land and groundwater. Therefore, the analytical framework adopted for this investigation is made up of a number of procedures, which are outlined below. All of these are based on a Risk Assessment methodology centred on the identification and analysis of Source – Pathway – Receptor linkages.

The CLEA model⁶ provides a methodology for quantitative assessment of the long term risks posed to human health by exposure to contaminated soils. Toxicological data is used to calculate a Soil Guideline Value (SGV) for an individual contaminant, based on the proposed site use; these represent minimal risk concentrations and may be used as screening values.

In the absence of any published SGVs for certain substances, Southern Testing have derived or adopted Tier 1 screening values for initial assessment of the soil, based on available current UK guidance including the LQM/CIEH⁷ S4UL's and CL:AIRE⁸ generic assessment criteria. In addition, in March 2014, DEFRA⁹ published the results of a research programme to develop screening values to assist decision making under Part 2A of the Environmental Protection Act. Category 4 screening levels were published for 6 substances, with reference to human health risk only. This guidance includes revisions of the CLEA exposure parameters, presenting parameters for public open space land use scenarios, and also of the toxicological approach. The screening levels represent a low risk scenario, based on a 'Low Level of Toxicological Concern' rather than the 'Minimal Risk' of CLEA, and the analytical results of this investigation may be considered relative to these levels.

The values used are valid at the time of writing but may be subject to change and any such changes will have implications for the assessments based upon them. Their validity should be confirmed at the time of site development.

Site-specific assessments are undertaken wherever possible and/or applicable.

CLEA requires a statistical treatment of the test results to take into account the normal variations in concentration of potential contaminants in the soil and allow comparisons to be made with published guidance.

The results of any groundwater analyses are compared to relevant quality criteria, eg EQS or DWS.

24 Site Investigation – Soil

24.1 Sampling Regime

The number of sample locations was limited due to access restrictions.

24.2 Testing

Although a desk study was not undertaken, so there is no conceptual model for the site, selected samples were analysed for a general range of potential contaminants, including heavy metals, PAH's, asbestos and organic contamination. On this basis, the following tests were selected.

⁶ Environment Agency Publication SC050021/SR3 'Updated technical background to the CLEA Model' (2009).

⁷ The LQM/CIEH S4ULs for Human Health Risk Assessment. (2014).

⁸ The EIC/AGS/CL:AIRE Soil Generic Assessment Criteria for Human Health Risk Assessment (2009).

⁹ SP1010 Development of Category 4 Screening Levels for Assessment of Land Affected by Contamination. DEFRA, 2014.

Test Suite	Number of Samples	Soil Tested
STL Key Contaminant Suite	3	Made Ground/Natural Soils
Asbestos Identification	2	Made Ground
TPH (CWG)	1	Natural Soils

The test results are presented in full in Appendix D. A summary and discussion of the significance of the results and identified contamination sources is given below.

24.3 Test Results and Identified Contamination Sources

24.3.1 General Contaminants

The results of the key contaminant tests have been analysed in accordance with the CLEA methodology. The samples have been grouped into 2 populations comprising Made Ground and Natural Soils. For each parameter in each population the sample mean is calculated and compared to a Tier 1 screening value. If the sample mean exceeds the screening value, the soil may be regarded as contaminated and further assessment may be required. If neither the sample mean nor any single value exceeds the screening value, the soil may be regarded as not contaminated, though further confirmatory assessment may be required. Where any single parameter value exceeds the screening value but the sample mean does not, further statistical analysis may be applied to that parameter if the available data is suitable. Such analysis would include an assessment of the Normality of the distribution of the data, consideration of the presence of outliers, and the calculation of a UCL estimate of the mean.

Summary data is presented in the tables below and the laboratory analysis is included in Appendix D. The screening values and source notes are presented in Table 1 "Tier 1 Screening Values" at the front of Appendix D.

Soil Type: Made Ground

Contaminants	Units	WS1 @ 0.3m	WS2 @ 0.45m	Residential without home grown produce consumption Tier 1 Screening Value
Arsenic (As)	mg/kg	13	15	40
Cadmium (Cd)	mg/kg	0.2	0.2	85
Total Chromium (Cr)	mg/kg	23	24	910
Hexavalent Chromium (CrVI)	mg/kg	<1	<1	6
Lead (Pb)	mg/kg	320	780	310
Mercury (Hg)	mg/kg	<1.0	2.4	9.2-15
Selenium (Se)	mg/kg	<3	<3	430
Nickel (Ni)	mg/kg	17	21	180
Copper (Cu)	mg/kg	41	49	7,100
Zinc (Zn)	mg/kg	1401	170	40,000
Phenol	mg/kg	<1.0	<1.0	750-2,300

Benzo[a]pyrene	mg/kg	0.2	0.1	2.6
Naphthalene	mg/kg	<0.1	0.5	2.3-13
Total Cyanide (CN)	mg/kg	<1	<1	/
Acidity (pH value)	Units	10.2	8.7	/
Soil Organic Matter	%	1.6	2.2	/

A total of two samples of made ground taken from across the site were sent for testing. Based on the results to date the made ground soil can be considered generally free from significant contamination, with the exception of some fairly minor lead impact. In our experience, however, the lead concentrations reported are fairly typical of made ground material in London and is not considered significant in terms of the development proposals and the likely risk to the site workers (assuming good, basic, health and safety measures are adopted) and the end users. Furthermore, given that the site is underlain by London Clay, there is no aquifer risk.

Soil Type: Natural Clay

Contaminants	Units	WS2 @ 0.6m	Residential without homegrown produce consumption Tier 1 Screening Value
Arsenic (As)	mg/kg	7	40
Cadmium (Cd)	mg/kg	<0.1	85
Total Chromium (Cr)	mg/kg	39	910
Hexavalent Chromium (CrVI)	mg/kg	<1	6
Lead (Pb)	mg/kg	140	310
Mercury (Hg)	mg/kg	<1.0	9.2-15
Selenium (Se)	mg/kg	<3	430
Nickel (Ni)	mg/kg	39	180
Copper (Cu)	mg/kg	30	7,100
Zinc (Zn)	mg/kg	79	40,000
Phenol	mg/kg	<1.0	750-2,300
Benzo[a]pyrene	mg/kg	<0.1	2.6
Naphthalene	mg/kg	<0.1	2.3-13
Total Cyanide (CN)	mg/kg	<1	/
Acidity (pH value)	Units	8.4	/
Soil Organic Matter	%	0.3	/

One sample of the natural clay soil, from WS2 @ 0.6m was also sent for testing. The results indicate that the sample tested can be considered essentially free from significant contamination with respect to human health and the proposed development.

24.3.2 Asbestos

No asbestos containing materials were detected in the samples analysed and none were observed in the exploratory holes. However, it should be noted that the exploratory holes are of small

diameter/the investigation was constrained by site usage and the samples obtained may not reflect the full composition of the soils on the site. Therefore, there is always the potential for pockets of asbestos or for asbestos containing materials to be present, which have not been detected in the sampling.

24.3.3 Organic Contaminants

One sample of the natural clay soil/possible made ground (WS3 @ 1.0m) which had a possible slight odour of hydrocarbon was sent for testing with respect to petroleum hydrocarbons. The results reported no concentrations of petroleum hydrocarbons above the detection limits.

25 Summary of Identified Contamination

Although a wider and formal contamination investigation was outside the requested scope of works, two samples of the made ground and one sample of the natural weathered London Clay tested were largely free from significant contamination. Some fairly minor impact with lead was reported in the Made Ground samples analysed. In our experience, however, this is typical of Made Ground in London and not considered significant in terms of the proposed development. Any minor risk to the groundworks contractor can be mitigated by implementing good basic health and safety measures, including the use of appropriate PPE.

26 Recommendations

It is anticipated that the made ground soils and natural soils on site will be removed, as part of the basement construction in particular, and deposited at an appropriate waste management facility. No specific remediation is considered necessary at this stage, although a discovery strategy should be put in place to deal with any significant contamination that comes to light during the development work.

The contamination results should be forwarded to this facility for confirmation of the waste classification, particularly whether the slight lead impact of the fill, will result in something other than an inert classification. The tip might require that WAC testing is carried out.

On the basis of these results, it appears that good general site practice, such as appropriate PPE and basic hygiene measures, will be sufficient to mitigate any minor risk to the ground workers. As with the waste management facility, these results should be provided to the ground workers for their appraisal.

As discussed, a careful watch should be kept for any more significant contamination that comes to light during the construction works, as part of a discovery strategy. This will need inspection, sampling and analysis; depending on the results, this may alter the remediation strategy, the waste classification and, possibly, site practices.

27 Discussion and Conclusions

Given the development proposals, and the contamination test results to date, no remediation is considered necessary. A discovery strategy should, however, be put in place to deal with any significant contamination that is encountered. Any such contamination will require inspection and sampling by an environmental engineer, with possible changes to the remediation strategy and waste classification. The results should be forwarded to the tips to allow classification of the material to be taken off-site as part of the development work.

28 General Guidance

Allowance should be made for experienced verification of any remedial works.

It may be that specific local requirements apply to this site, of which we are not aware at this time.

In general terms, the workforce and general public should be protected from contact with contaminated material. There is a range of relevant documents published by the Health and Safety Executive, and organisations such as CIRIA, and the BRE.

Some soils will require removal from site and disposal to suitably licensed landfills. Different guidelines and charges will apply to different waste classification. As waste producers, the Developer holds responsibilities under the various governing regulations. The chemical analyses appended to this report should be forwarded to tip operators for their own assessment, to confirm classification of the soils for offsite disposal, and whether they can accept the material. Waste Acceptance Criteria (WAC) testing may be requested for confirmation of the material's classification.

All hazardous and non-hazardous soils leaving site will need to be pre-treated. Waste minimisation by selective excavation is a recognised form of pre-treatment.

Many water supply companies now require higher specification pipe on contaminated sites, even following remediation.

APPENDIX A

Site Plans and Exploratory Hole Logs

Key to Exploratory Hole Logs

General

All soil & rock descriptions in general accordance with BS5930:1999+A2:2010, BS EN ISO 14688 & BS EN ISO 14689
The Geology Code only entered where positive identification of the sampled strata has been made

Sampling

ES	Environmental Sample (taken in appropriate sampling container)
D	Disturbed Sample
B	Bulk Sample
LB	Large Bulk for Earthworks testing
C	Core Sample
U	Undisturbed Sample (number of blows indicated in results column)
SPTLS	SPT Liner Sampler
P	Piston Sample
W	Water Sample

In situ Tests

SPT	Standard Penetration Test in accordance with BS EN ISO 22476-3:2005+A1:2011
SPT (C)	Cone Penetration Test in accordance with BS EN ISO 22476-3:2005+A1:2011
PT	Penetration Test - STL documented equivalent SPT N Value
PPT	Perth Penetration Test - STL in house documented method (N Value)
UCS (—)	Unconfined Compressive Strength measure by hand penetrometer (kN/m ²)
IVN	Hand Vane (kPa)
PID	Photo Ionisation Detector Results (ppm)
MEXE	Mexecon CBR Result

Drilling Records

Depth to standing water level	▼
Depth to water strike	▽
TCR	Total Core Recovery (%)
SCR	Solid Core Recovery (%)
RQD	Rock Quality Index (%)
FI	Fracture Index

Backfill Symbols

Arisings	
Concrete	
Blacktop	
Bentonite Seal	
Gravel Filter	
Sand Filter	

Pipe Symbols

Plain Pipe	
Slotted Pipe	
Filter Tip	

Principal Soil Types

Topsoil	
Made Ground	
Clay	
Silt	
Sand	
Gravel	
Peat	

Principal Rock Types

Mudstone/Claystone	
Siltstone	
Sandstone	
Limestone	
Chalk	

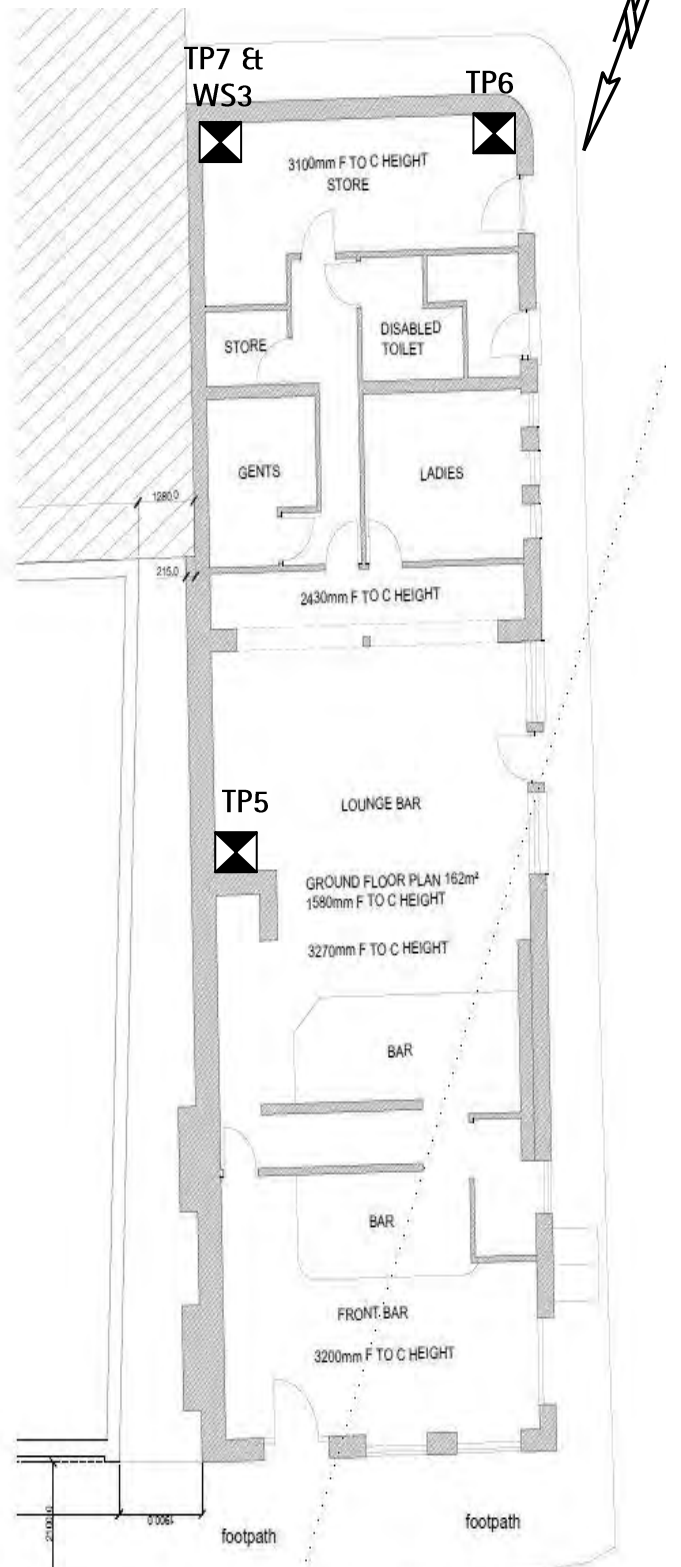
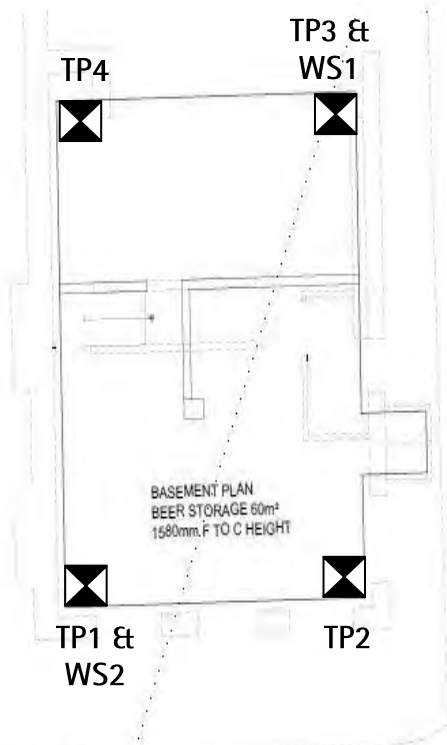

NB: Positions of Boreholes and/or Trial Pits are only indicative unless dimensioned

Site: The Admiral Mann Public House, 9 Hargrave Place (London N7)

STL: J12113

Fig No: 1

Date: 15 January 2015

Site plan showing hole locations

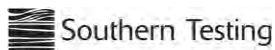

Southern Testing: Keeble House, Stuart Way, East Grinstead, West Sussex RH19 4QA
ST Consult: Twigden Barns, Brixworth Road, Creton, Northampton NN6 8NN



Project Name: Admiral Mann Public House, 9 Hargrave Place, (London N7)

Remarks: **Co-ordinates:** **Level (m AOD):** **Logger:** HC/SM

Location: London N7

1. Standing water level at 0.27m below basement floor level, 15 minutes after completion.

Client: Lyons O'Neil

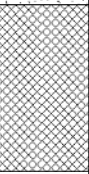
Samples and Insitu Testing			Level (m AOD)	Thickness (m)	Legend	Depth (m bgl)	Stratum Description
Depth (m)	Type	Results					
				(0.13)		0.13	CONCRETE
				(0.22)		0.35	Grey brown, clayey, fine to medium, SAND, with frequent fragments of brick, concrete and flint gravel (MADE GROUND).
							Pit terminated at 0.35m.

Pit Dimension (m)		Pit Stability:	Water Strikes:
Width:			
Length:			
Depth:	0.35		



Project Name: Admiral Mann Public House, 9 Hargrave Place, (London N7)

Remarks: **Co-ordinates:** **Level (m AOD):** **Logger:**
HC/SM

Location: London N7

1. Standing water level at 0.36m below basement floor level, 10 minutes after completion.

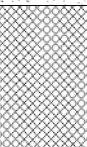
Client: Lyons O'Neil

Samples and Insitu Testing			Level (m AOD)	Thickness (m)	Legend	Depth (m bgl)	Stratum Description
Depth (m)	Type	Results					
0.3	HP	UCS(kPa)=100		(0.05)		0.05	CONCRETE
				(0.19)		0.24	Firm, brown, sandy, CLAY, with frequent fragments of brick, ash and concrete (MADE GROUND)
				(0.18)		0.42	Firm, medium strength, brown, CLAY
							Pit terminated at 0.42m.

1

2

Pit Dimension (m)		Pit Stability:	Water Strikes:
Width:			
Length:			
Depth:	0.42		

Project Name: Admiral Mann Public House, 9 Hargrave Place, (London N7)

Remarks: **Co-ordinates:** **Level (m AOD):** **Logger:**
HC/SM

Location: London N7

1. Pit dry upon completion.

Client: Lyons O'Neil

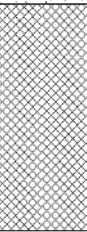
Samples and Insitu Testing			Level (m AOD)	Thickness (m)	Legend	Depth (m bgl)	Stratum Description
Depth (m)	Type	Results					
				(0.15)		0.15	CONCRETE
				(0.30)		0.45	Orange brown, sandy, CLAY, with frequent fragments of brick, concrete and fine flint gravel (MADE GROUND).
							Pit terminated at 0.45m.

Pit Dimension (m)		Pit Stability:	Water Strikes:
Width:			
Length:			
Depth:	0.45		

Project Name: Admiral Mann Public House, 9 Hargrave Place, (London N7)

Remarks: **Co-ordinates:** **Level (m AOD):** **Logger:** HC/SM

Location: London N7

1. Standing water level at 0.23m below basement floor level, 15 minutes after completion.

Client: Lyons O'Neil

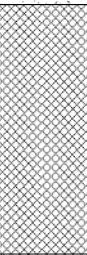
Samples and Insitu Testing			Level (m AOD)	Thickness (m)	Legend	Depth (m bgl)	Stratum Description
Depth (m)	Type	Results					
				(0.07)		0.07	CONCRETE
				(0.33)		0.40	Orange brown to grey brown, clayey, fine to coarse SAND, with frequent fragments of brick, concrete and flint gravel (MADE GROUND).
							Pit terminated at 0.40m.

1

2

Pit Dimension (m)		Pit Stability:		Water Strikes:	
Width:					
Length:					
Depth:	0.40				

Project Name: Admiral Mann Public House, 9 Hargrave Place, (London N7)

Remarks: **Co-ordinates:** **Level (m AOD):** **Logger:**
HC/SM

Location: London N7

1. Pit dry upon completion.

Client: Lyons O'Neil

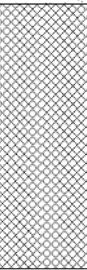
Samples and Insitu Testing			Level (m AOD)	Thickness (m)	Legend	Depth (m bgl)	Stratum Description
Depth (m)	Type	Results					
				(0.10)		0.10	CONCRETE
				(0.35)		0.45	Grey brown, clayey, fine to medium SAND, with frequent fragments of brick, concrete, slate, glass and flint gravel (MADE GROUND).
							Pit terminated at 0.45m.

1

2

Pit Dimension (m)		Pit Stability:	Water Strikes:
Width:			
Length:			
Depth:	0.45		

Project Name: Admiral Mann Public House, 9 Hargrave Place, (London N7)

Remarks: Co-ordinates: Level (m AOD): **Logger:** HC/SM

Location: London N7

1. Pit dry upon completion.

Client: Lyons O'Neil

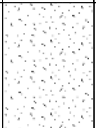
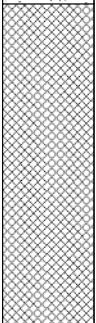
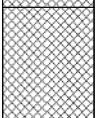
Samples and Insitu Testing			Level (m AOD)	Thickness (m)	Legend	Depth (m bgl)	Stratum Description
Depth (m)	Type	Results					
0.4	ES			(0.17)		0.17	CONCRETE
				(0.43)			Grey brown, slightly clayey, fine to medium SAND, with frequent fragments of brick, concrete, ash, slate and flint gravel (MADE GROUND).
				(0.15)		0.60	Firm, brown, sandy, CLAY, with occasional fragments of brick and flint gravel (MADE GROUND).
						0.75	Pit terminated at 0.75m.

Pit Dimension (m)		Pit Stability:	Water Strikes:
Width:			
Length:			
Depth:	0.75		

Project Name: Admiral Mann Public House, 9 Hargrave Place, (London N7)

Remarks: **Co-ordinates:** **Level (m AOD):** **Logger:**
HC/SM

Location: London N7

1. pit dry upon completion.

Client: Lyons O'Neil

Samples and Insitu Testing			Level (m AOD)	Thickness (m)	Legend	Depth (m bgl)	Stratum Description
Depth (m)	Type	Results					
				(0.14)		0.14	CONCRETE
				(0.46)			Grey brown, clayey, fine to medium SAND, with frequent fragments of brick, concrete, slate, glass, ash and flint gravel (MADE GROUND).
				(0.15)		0.60	Firm, brown to orange brown, sandy, CLAY, with occasional fragments of brick and flint gravel (MADE GROUND).
						0.75	Pit terminated at 0.75m.

Pit Dimension (m)		Pit Stability:	Water Strikes:
Width:			
Length:			
Depth:	0.75		

Notes

1. All dimensions in mm unless stated otherwise.

TP1 Plan View

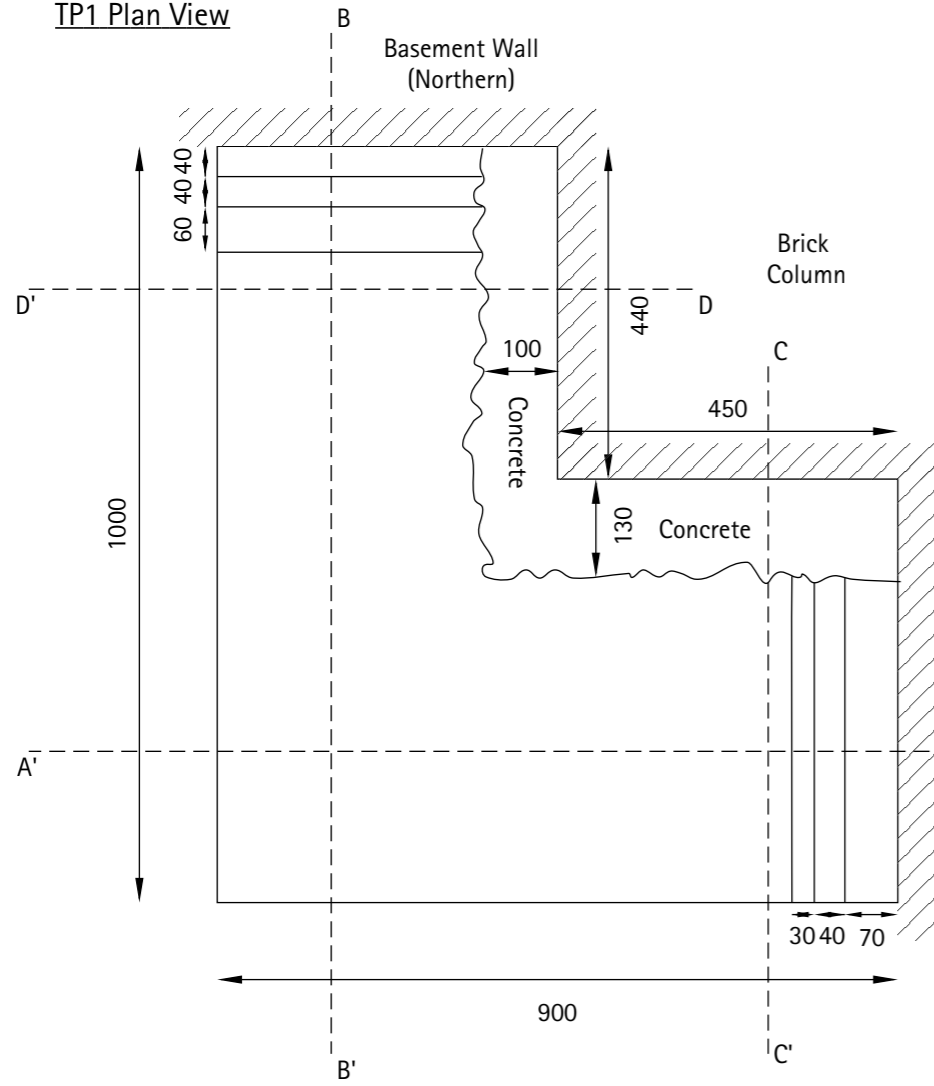

TP1 Section A-A'

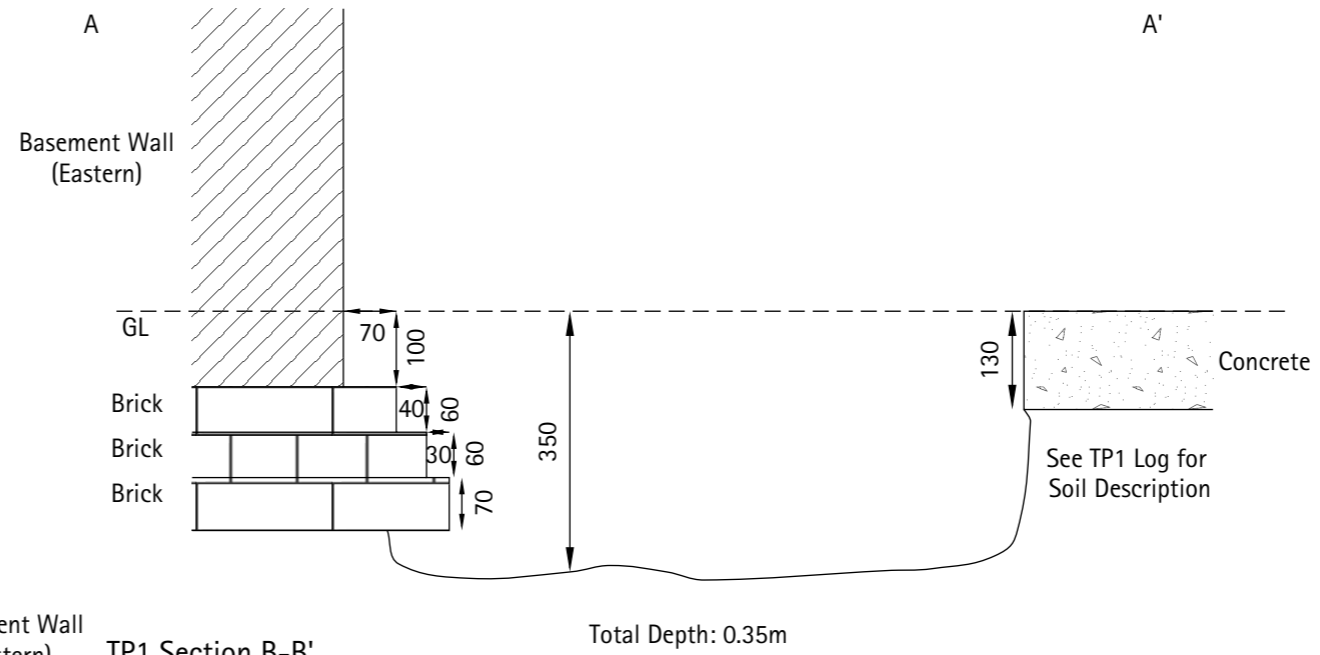

TP1 Section B-B'

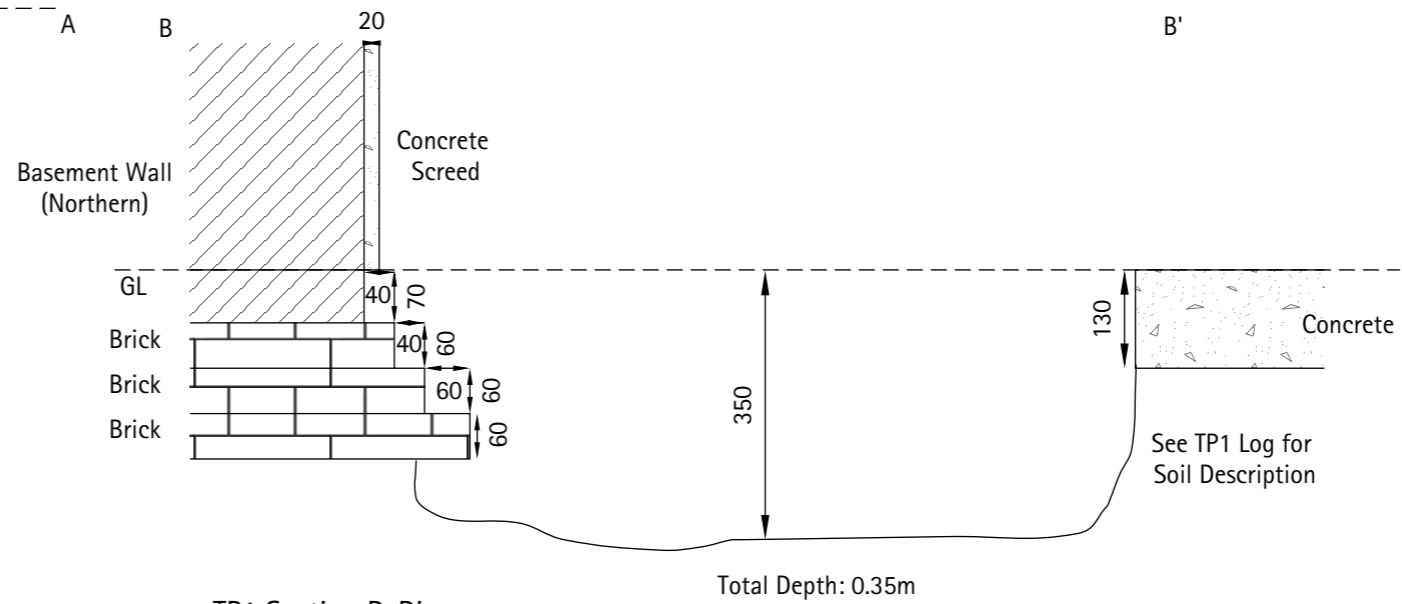

TP1 Section C-C'

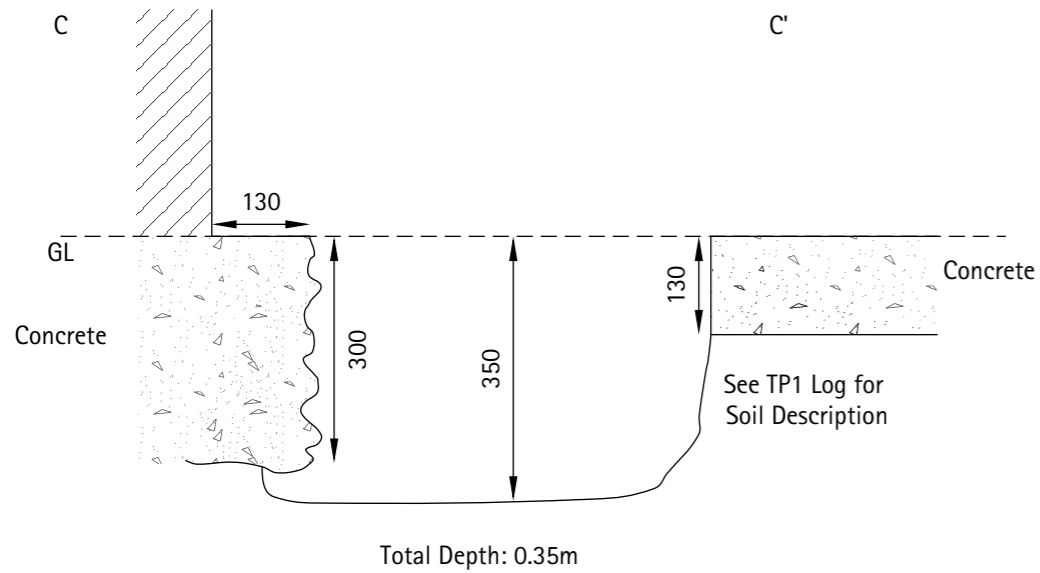

TP1 Section D-D'

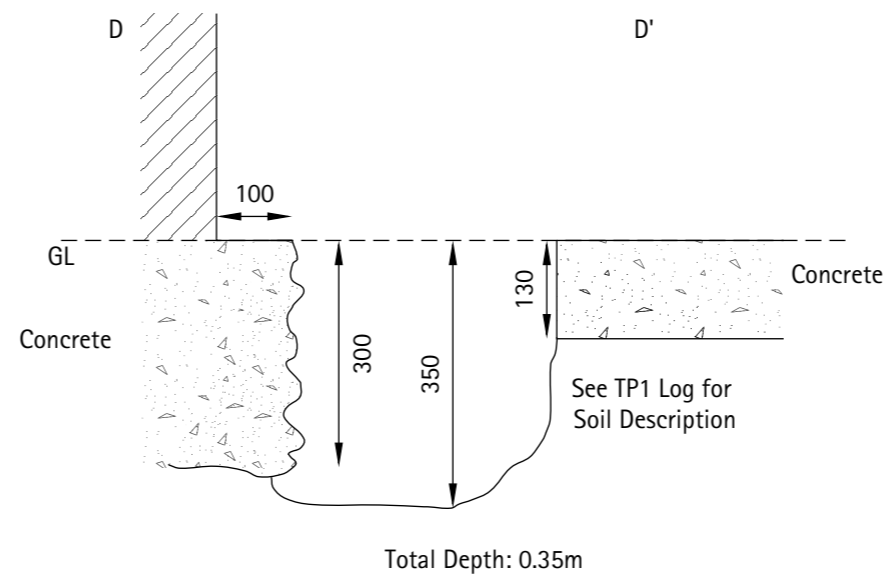

Keeble House, Stuart Way, East Grinstead, West Sussex. RH19 4QA

Tel: 01342 333100 Fax: 01342 410321 www.southernesting.co.uk

Client: Lyons O'Neil

Job Title: The Admiral Mann Public House
9 Hargrave Place
(London N7)

Description: Trial Pit Sections

Drawing No: TP1

Scale: 1:100

Paper Size: A3

Drawn by: SM

Checked by: DV

Date: 13/01/2015

Notes

1. All dimensions in mm unless stated otherwise.

TP2 Plan View

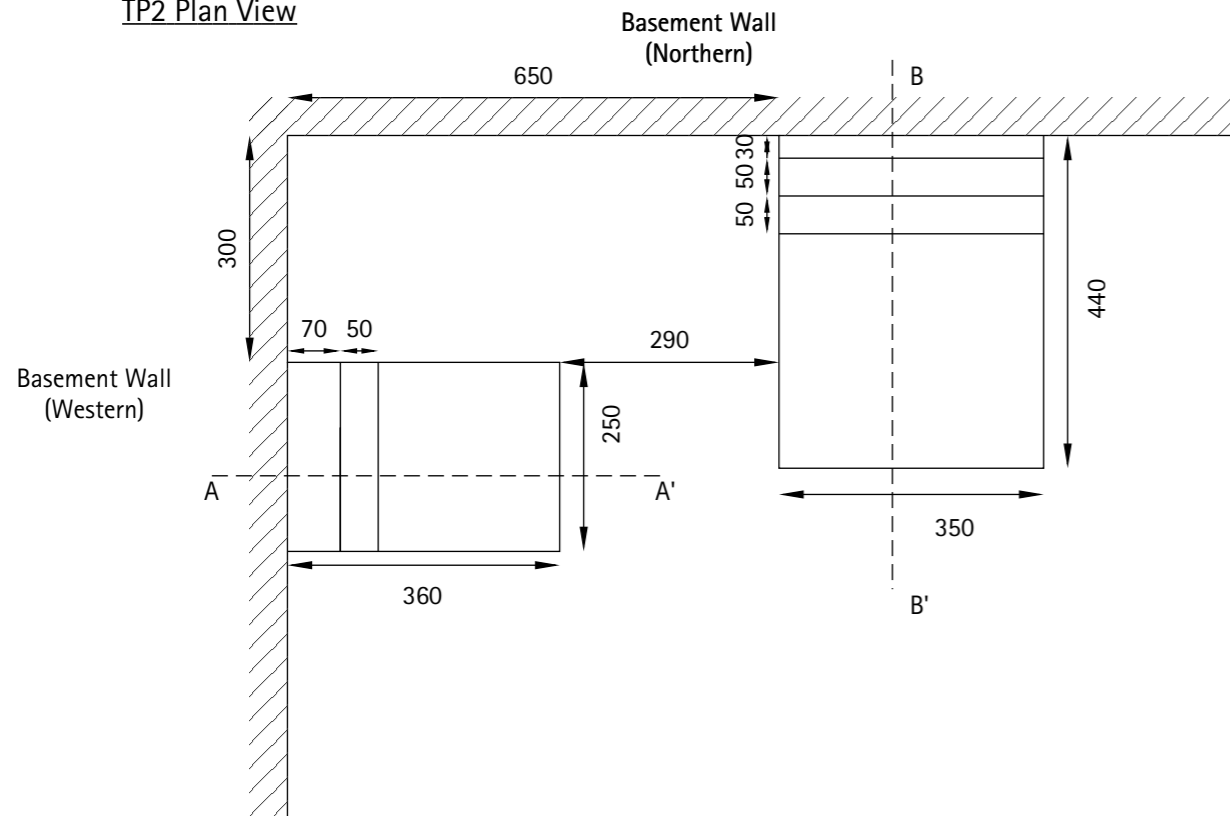

TP2 Section A-A'

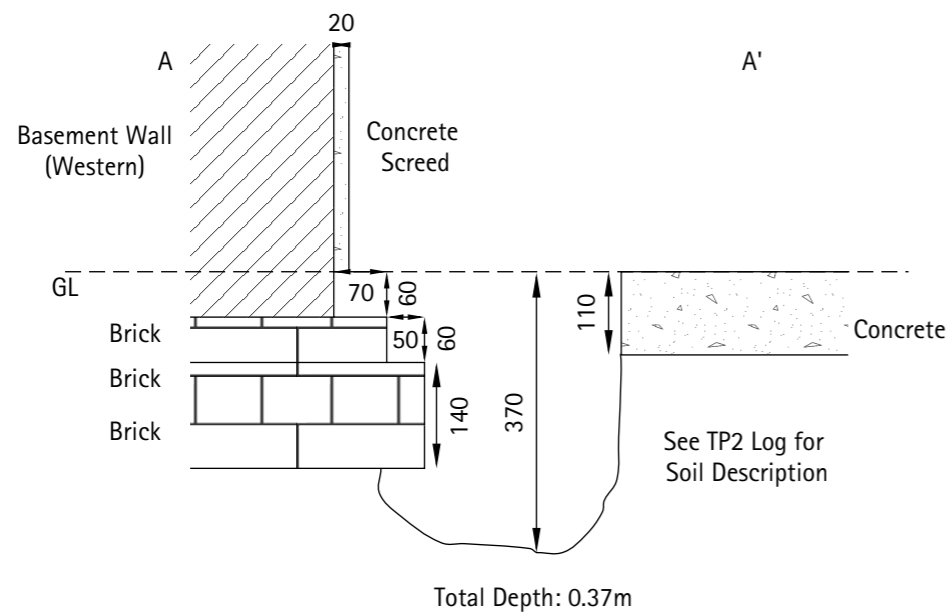

TP2 Section B-B'

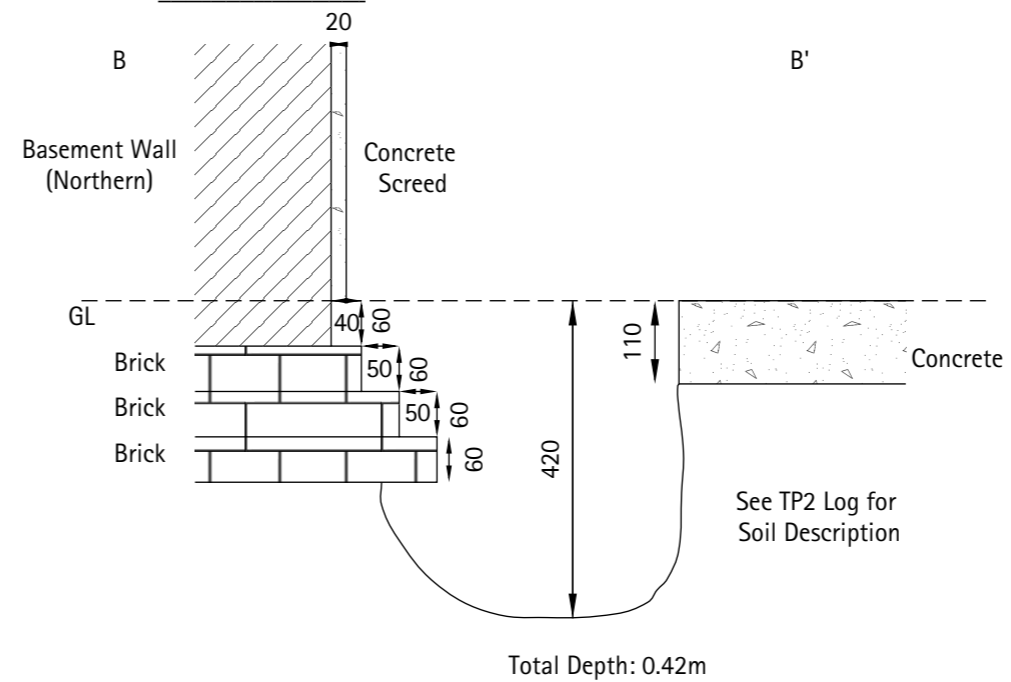

Southern Testing
 Environmental & Geotechnical
 Keeble House, Stuart Way, East Grinstead,
 West Sussex. RH19 4QA
 Tel: 01342 333100 Fax: 01342 410321
 www.southern-testing.co.uk

Client: Lyons O'Neil

Job Title: The Admiral Mann Public House
 9 Hargrave Place
 (London N7)

Description: Trial Pit Sections

Drawing No: TP2

Scale: 1:100

Paper Size: A3

Drawn by: SM

Checked by: DV

Date: 13/01/2015

Notes

1. All dimensions in mm unless stated otherwise.

TP3 Plan View

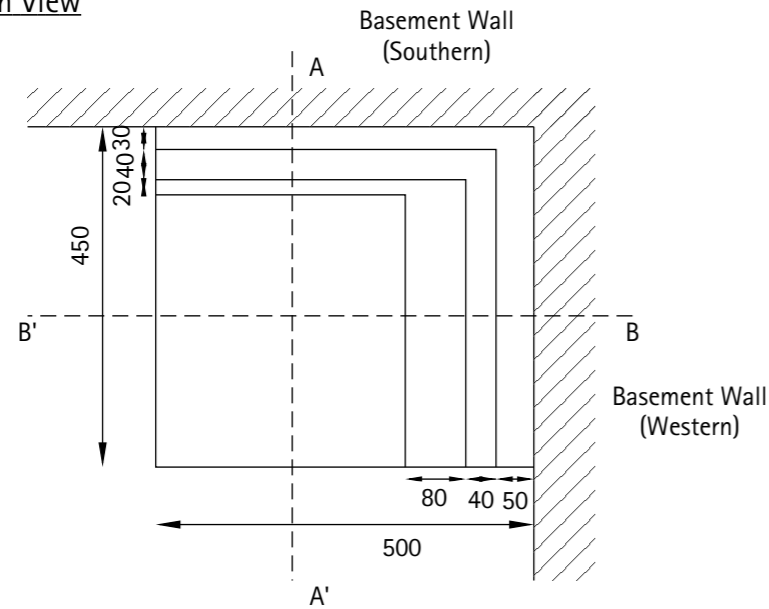

TP3 Section A-A'

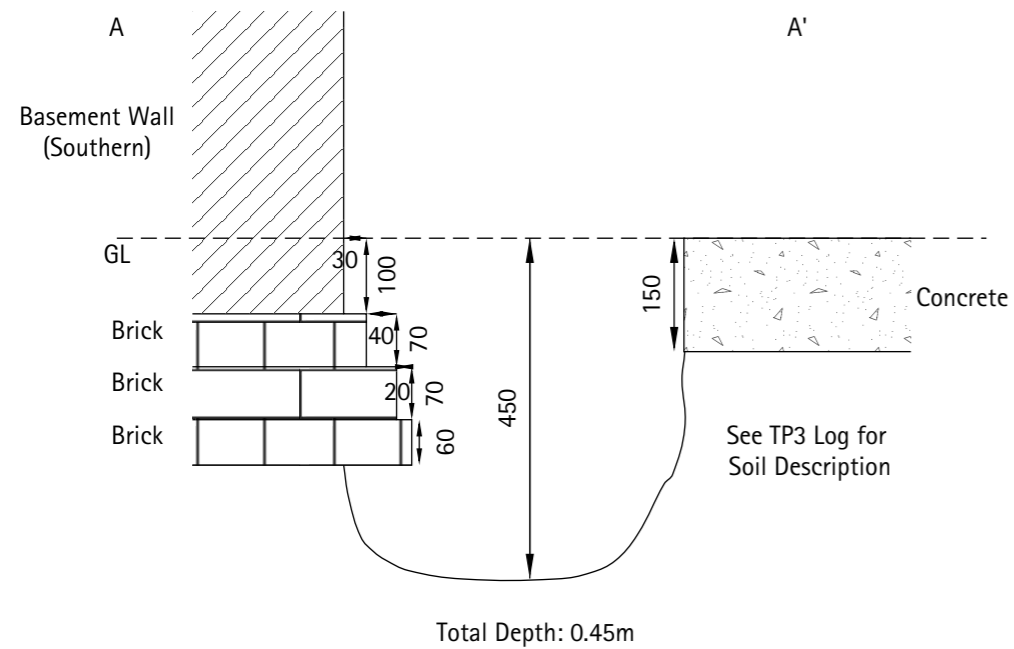

TP3 Section B-B'

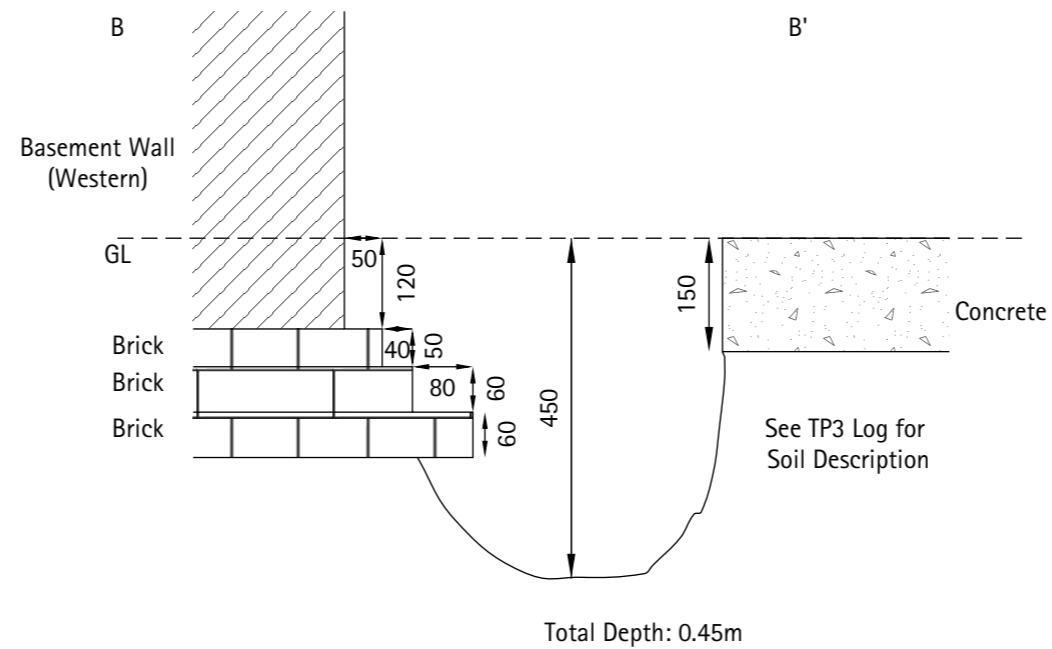

Southern Testing
 Environmental & Geotechnical
 Keeble House, Stuart Way, East Grinstead,
 West Sussex. RH19 4QA
 Tel: 01342 333100 Fax: 01342 410321
 www.southernesting.co.uk

Client: Lyons O'Neil

Job Title: The Admiral Mann Public House
 9 Hargrave Place
 (London N7)

Description: Trial Pit Sections

Drawing No: TP3

Scale: 1:100 Paper Size: A3

Drawn by: SM Checked by: DV

Date: 13/01/2015

TP4 Plan View

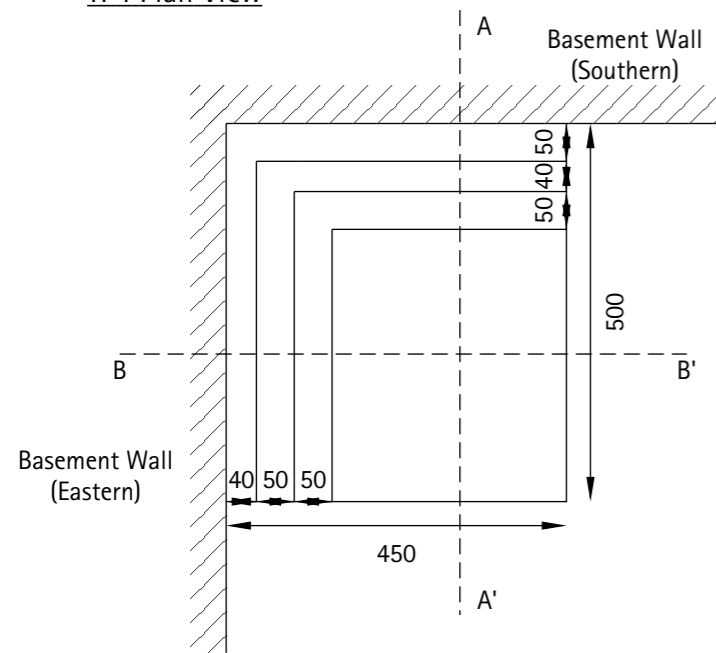

TP4 Section A-A'

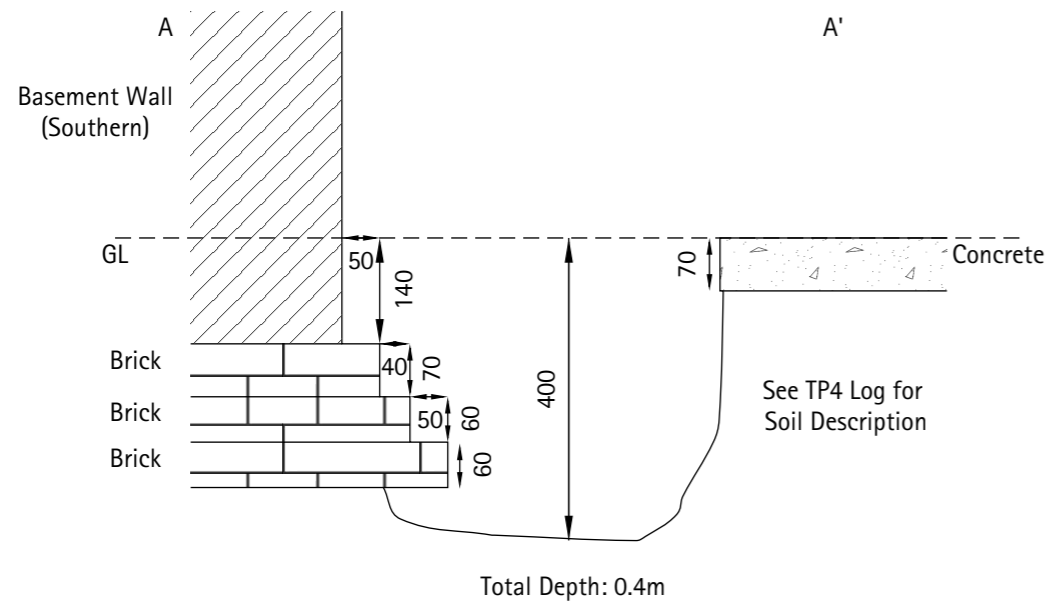

TP4 Section B-B'

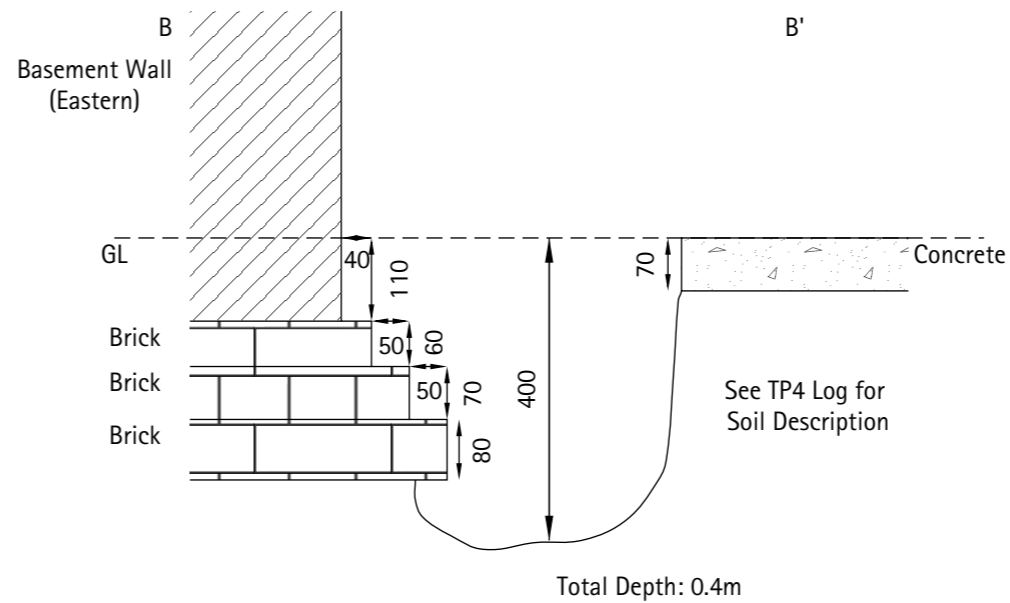

Notes

1. All dimensions in mm unless stated otherwise.



Keeble House, Stuart Way, East Grinstead,
West Sussex. RH19 4QA

Tel: 01342 333100 Fax: 01342 410321
www.southerntesting.co.uk

Client: Lyons O'Neil

Job Title: The Admiral Mann Public House
9 Hargrave Place
(London N7)

Description: Trial Pit Sections

Drawing No: TP4

Scale: 1:100

Paper Size: A3

Drawn by: SM

Checked by: DV

Date: 13/01/2015

TP5 Plan View

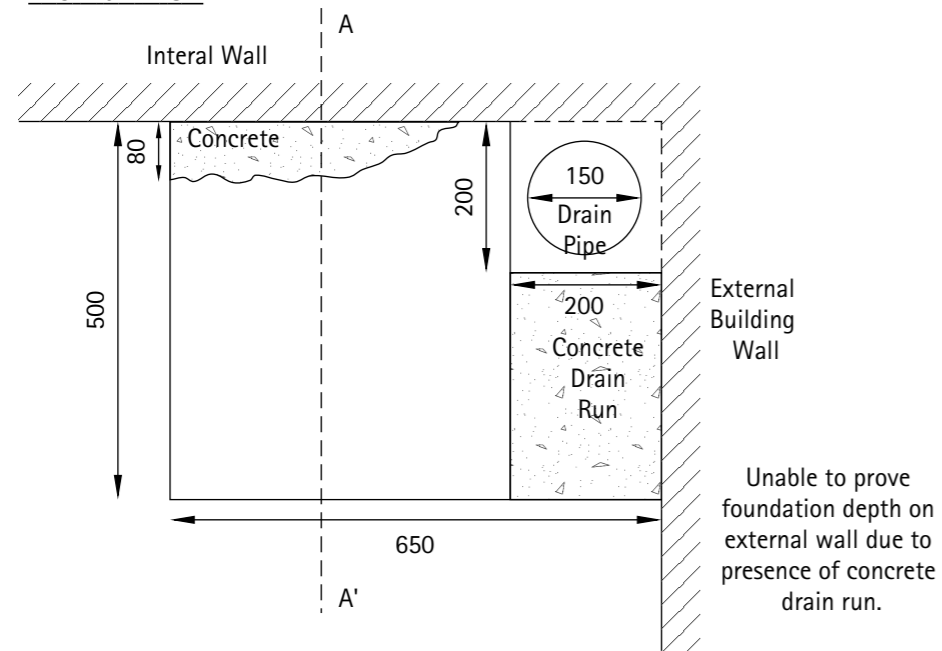

TP5 Section A-A'

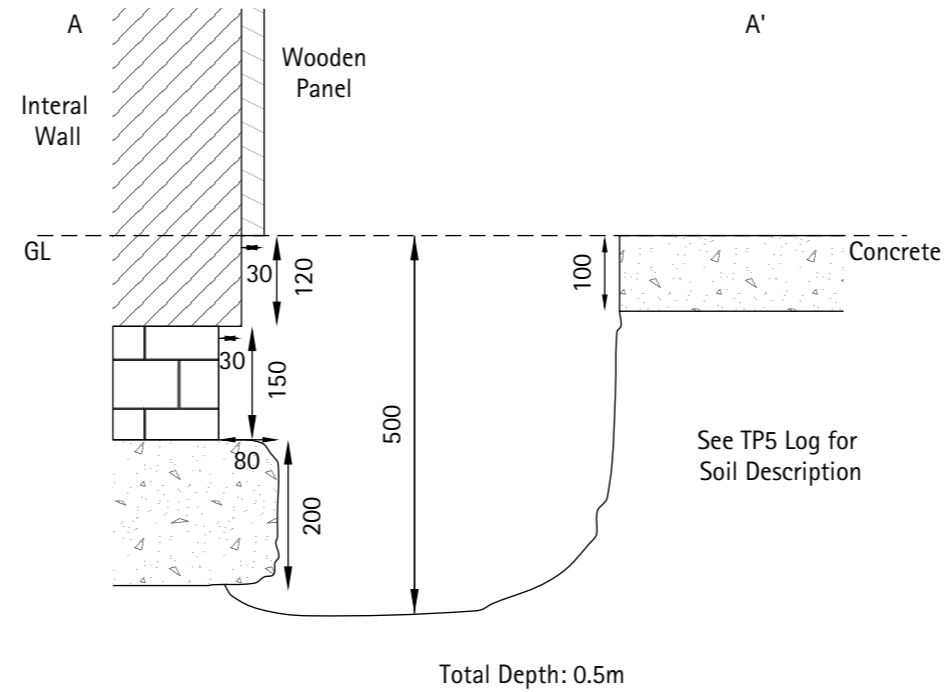

Notes

1. All dimensions in mm unless stated otherwise.
2. Unable to prove foundation depth on external wall in TP5 due to presence of concrete drain run.

TP6 Plan View

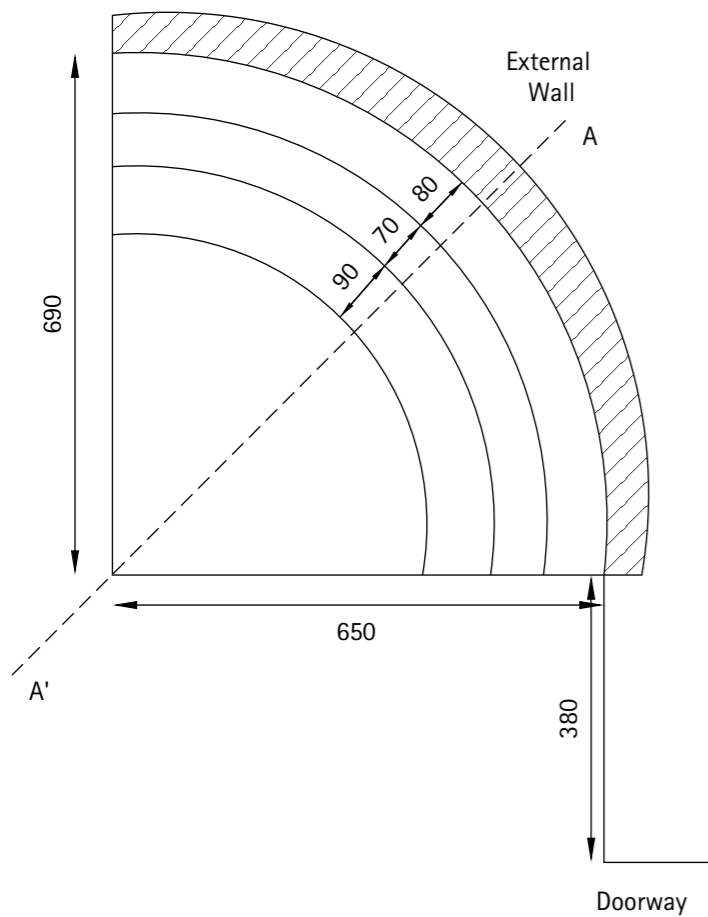

TP6 Section A-A'

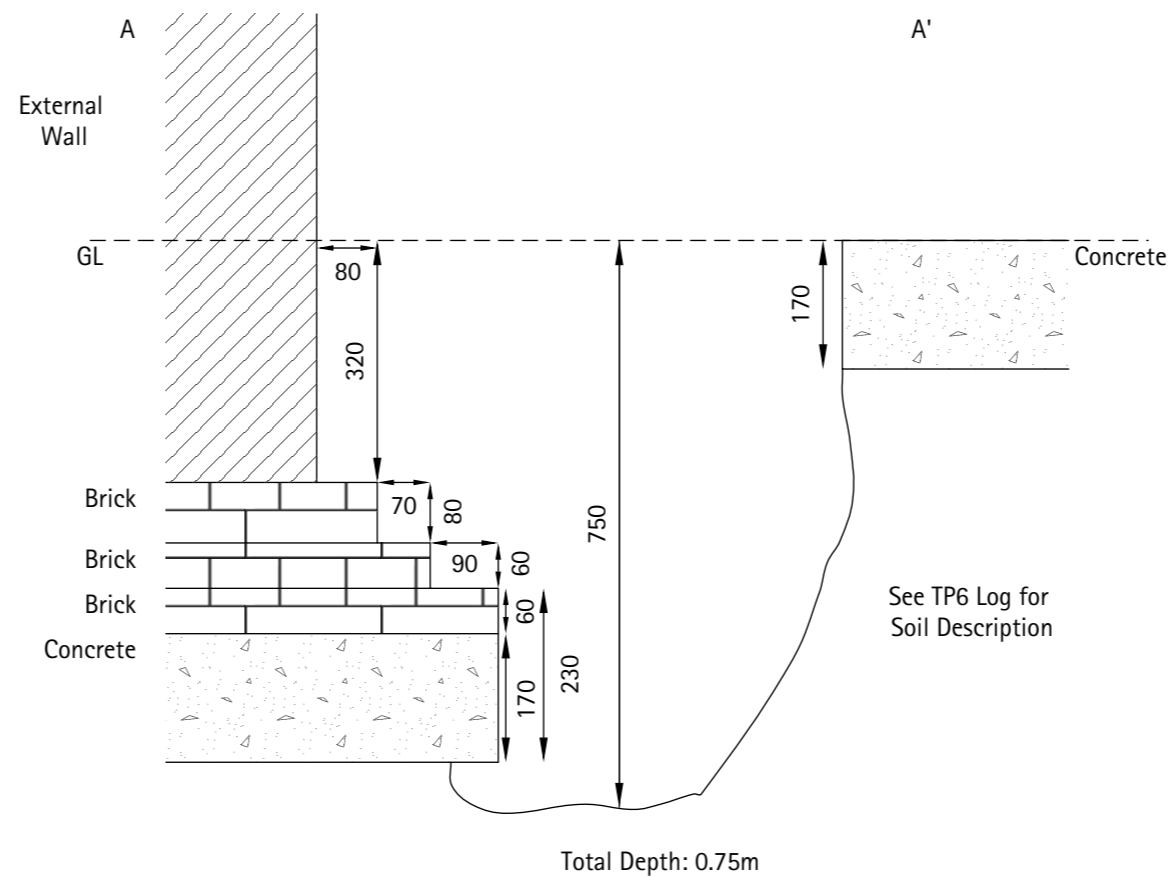

Keeble House, Stuart Way, East Grinstead,
West Sussex. RH19 4QA
Tel: 01342 333100 Fax: 01342 410321
www.southerntesting.co.uk

Client: Lyons O'Neil

Job Title: The Admiral Mann Public House
9 Hargrave Place
(London N7)

Description: Trial Pit Sections

Drawing No: TP5 & TP6

Scale: 1:100

Paper Size: A3

Drawn by: SM

Checked by: DV

Date: 13/01/2015

Notes

1. All dimensions in mm unless stated otherwise.

TP7 Plan View

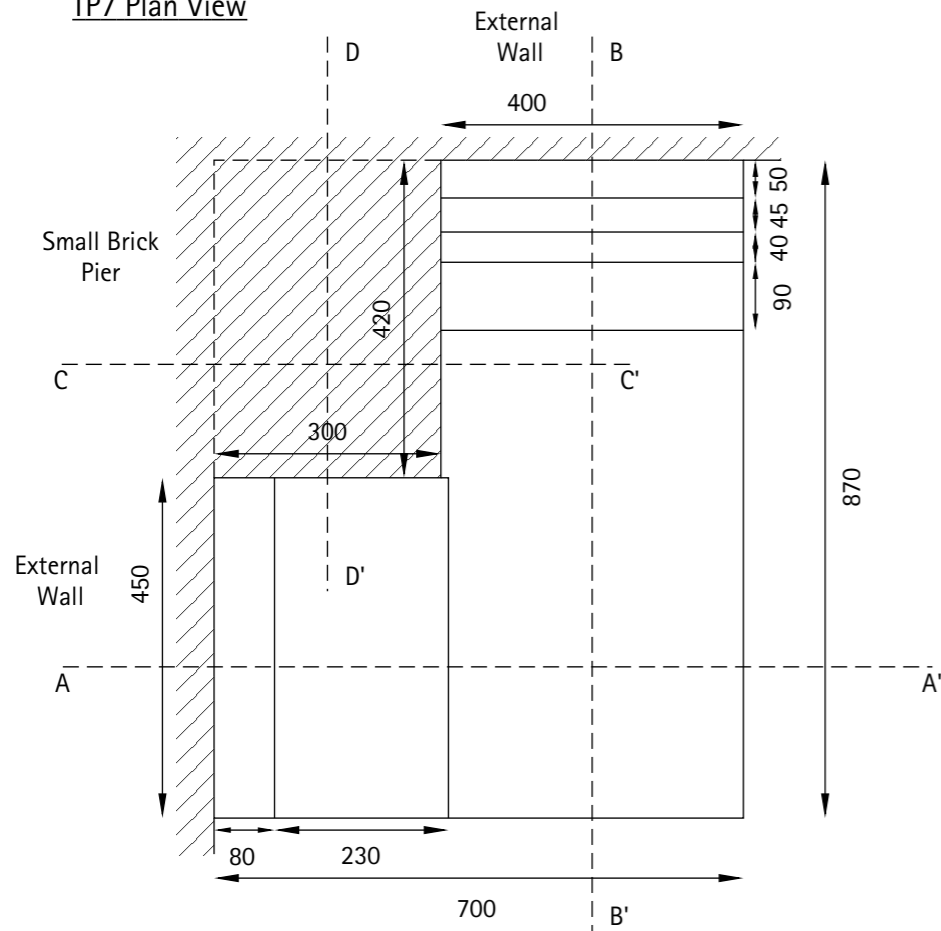

TP7 Section A-A'

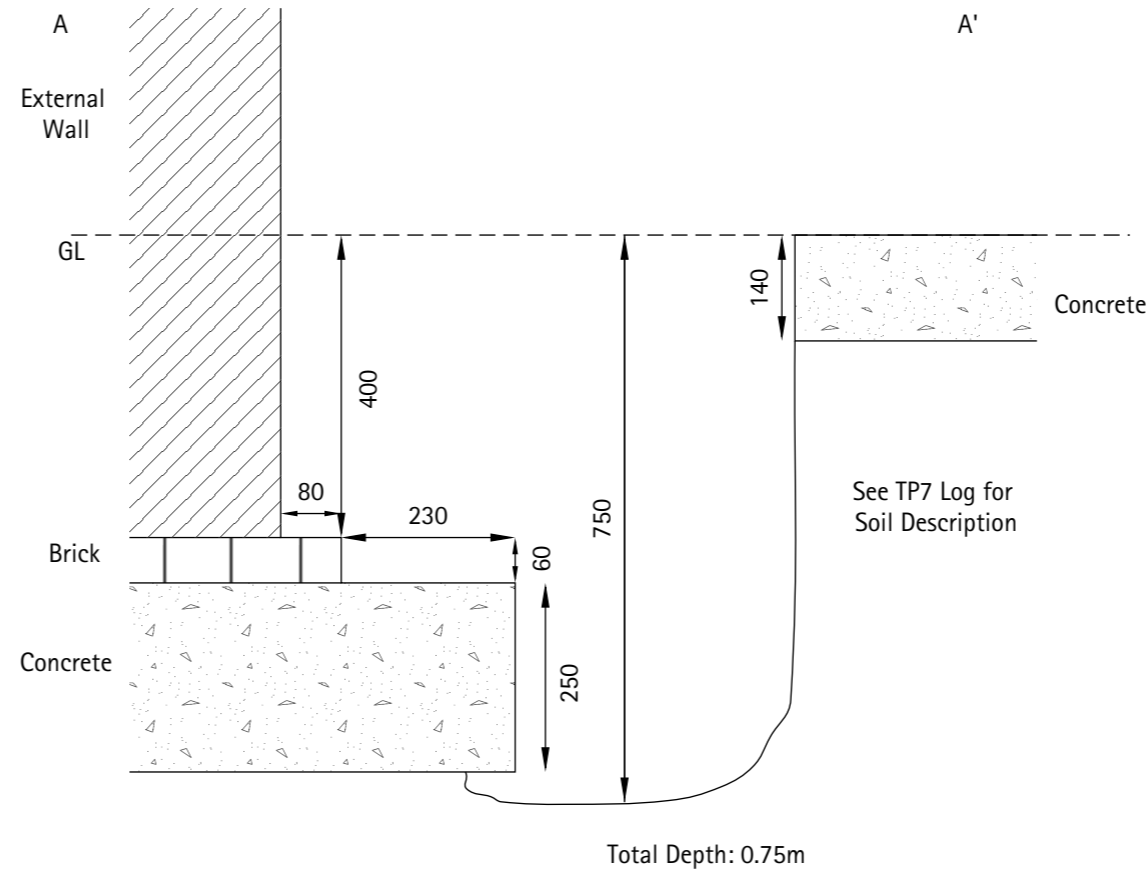

TP7 Section B-B'

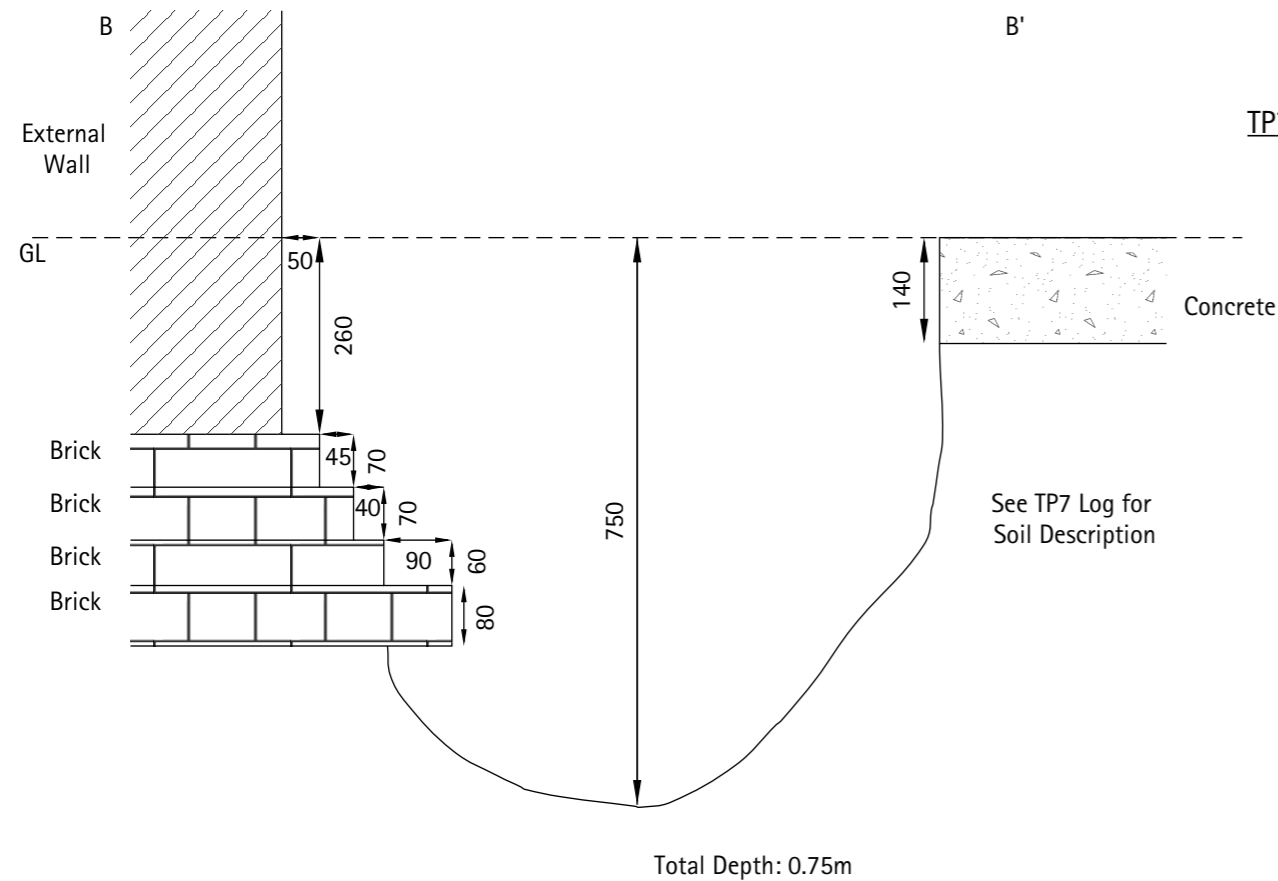

TP7 Section C-C'

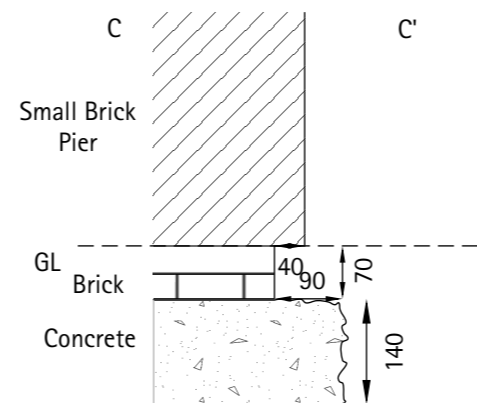

TP7 Section D-D'

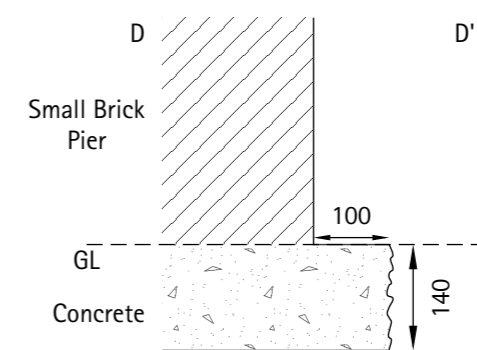

Keeble House, Stuart Way, East Grinstead, West Sussex. RH19 4QA

Tel: 01342 333100 Fax: 01342 410321 www.southernesting.co.uk

Client: Lyons O'Neil

Job Title: The Admiral Mann Public House
9 Hargrave Place
(London N7)

Description: Trial Pit Sections

Drawing No: TP7

Scale: 1:100

Paper Size: A3

Drawn by: SM

Checked by: DV

Date: 13/01/2015

J12113 Admiral Mann Public House (London N7)



TP1



TP2



TP2 Northern Wall



TP2 Western Wall



TP3



TP4

J12113 Admiral Mann Public House (London N7)



TP5



TP6



TP7

APPENDIX B

Field Sampling and in-situ Test Methods & Results

Field Sampling and in-situ Test Methods

Disturbed Samples

Disturbed samples were taken from the trial holes at intervals and stored in sealed glass jars and polythene bags, as appropriate.

Undisturbed U100 Samples

Undisturbed U100 samples were taken in the clay soils at appropriate intervals. These samples are taken in a 100 mm diameter, 450 mm long, thin-walled steel tube, and are sealed with paraffin wax and tightly fitting end caps for transporting to the laboratory.

Standard Penetration Test

The Standard Penetration (SPT) Test is specified in BS EN ISO 22476-3:2005+A1:2011. In this test, a 51mm diameter open-ended tube is driven into the ground by a 63.5 kg hammer falling freely through 760 mm. The tube is seated by driving to a penetration of 150mm, or by 25 standard blows, whichever occurs first. It is then driven for a maximum of a further 300mm and the number of blows is termed the penetration resistance (N). If 300mm penetration cannot be achieved in 50 blows (100 blows in soft rock), the test drive is terminated.

When testing in gravels, a conical end piece is attached to the tube. The test is then called an SPT(C).

This test provides an indirect method of assessing the properties of cohesionless soils, and the following table (after Terzaghi and Peck) gives the approximate condition:-

Number Blows (N)	Density
0 - 4	Very Loose
4 - 10	Loose
10 - 30	Medium Dense
30 - 50	Dense
Over 50	Very Dense

Clay

An approximate value for the shear strength of clay may be obtained using Stroud (1974), which paper indicates that the cohesive strength is a function of plasticity and SPT 'N' value. The relation is:

$$C_u = f_i \times N \text{ kPa}$$

$$C_u = \text{undrained shear strength}$$

$$f_i = \text{factor related to plasticity index and ranging from 4 to more than 6}$$

The SPT test is not generally accepted as giving a reliable indication of the strength of cohesive soils but it does give a guide; often the following table:-

Number Blows (N)	Soil Strength
Less than 2	Very Soft (Very Low Strength)
2 - 5	Soft (Low Strength)
5 - 10	Firm (Medium Strength)
10 - 15	Stiff (High Strength)
15 - 30	Very Stiff (Very High Strength)

APPENDIX C

Geotechnical Laboratory Test References & Results

Atterberg and Moisture Content Summary

To BS1377-2:1990(2003) cl.3.2, 3.3, 4.2, 4.3

Project Name		The Admiral Mann PH (London N7)					Project Number		J12113	
Client		Lyons O'Neill			PE	DV	Date Issued		22-Jan-15	
Location	Depth m	Sample Type	Visual Description	Comments	Natural MC %	Liquid Limit %	Plastic Limit %	Plasticity Index	Classi- fication	Passing 425 micron %
WS1	1.00	D	Stiff high strength light brown CLAY.		32	80	26	54	CV	100
WS3	1.50	D	Stiff high strength brown CLAY.		34	84	26	58	CV	100
WS2	2.00	D	Stiff high strength light brown CLAY.		31	75	28	47	CV	100
WS1	3.00	D	Stiff high strength brown CLAY with frequent selenite crystals.		28	78	24	54	CV	99

Southern Testing Laboratories Limited, East Grinstead is registered under BS EN ISO 9001:2008 BSI ref: FS29280

Jun 13

Plasticity Chart for Atterberg Limit Tests



Project Name	The Admiral Mann PH (London N7)	Project Number	J12113
Client Name	Lyons O'Neill	PE	DV
		Date Issued	22-Jan-15

Key

No.	TH No.	Depth
1	WS1	1.00
2	WS3	1.50
3	WS2	2.00
4	WS1	3.00

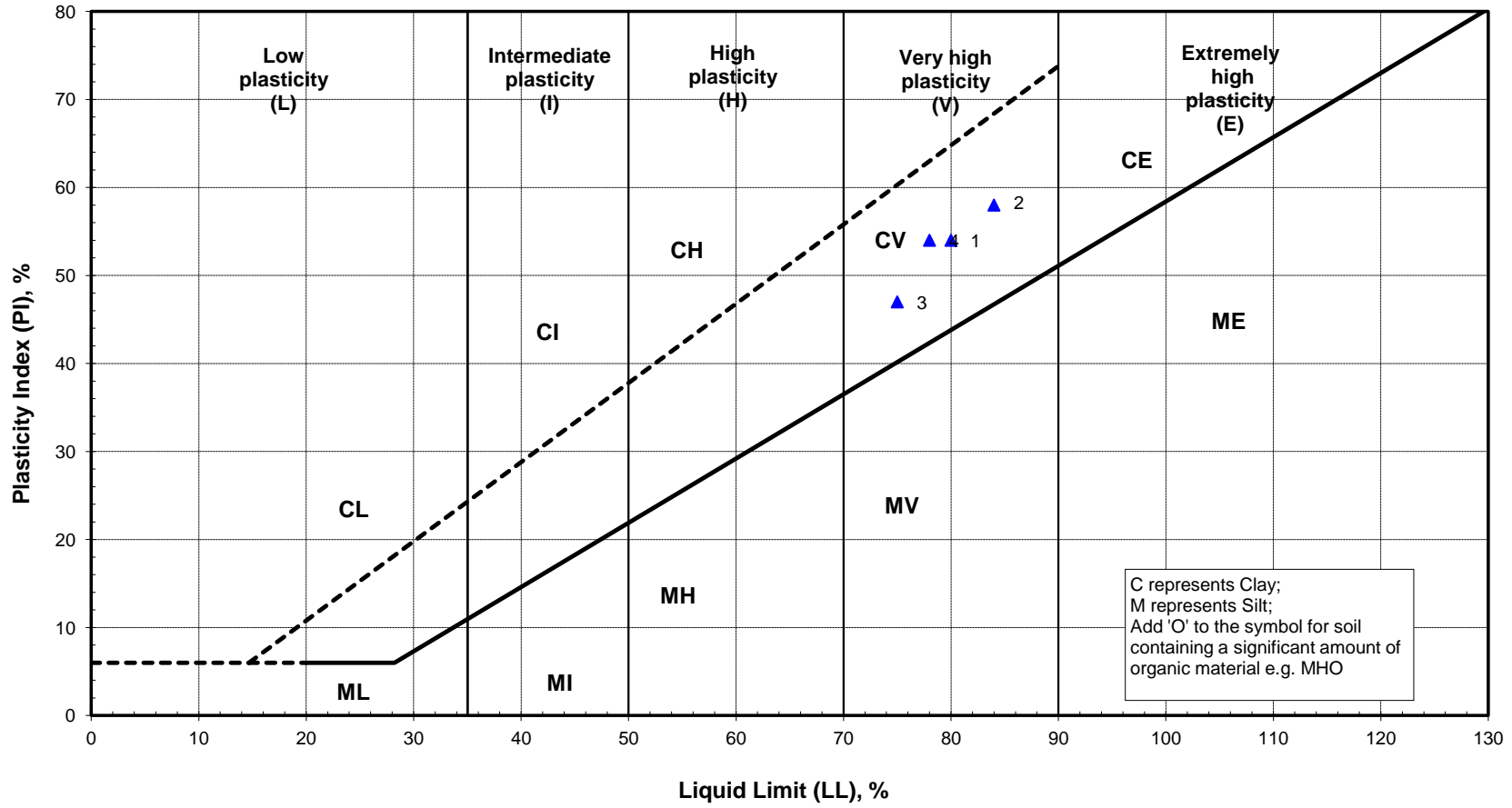

C represents Clay;
M represents Silt;
Add 'O' to the symbol for soil containing a significant amount of organic material e.g. MHO

Liquid Limit		Plastic Limit		Plasticity Index	
Maximum Value	84	Maximum Value	28	Maximum Value	58
Minimum Value	75	Minimum Value	24	Minimum Value	47
Average Value	79	Average Value	26	Average Value	53

NHBC Classification for Volume Change Potential



Project Name	The Admiral Mann PH (London N7)	Project Number	J12113
Client Name	Lyons O'Neill	PE	DV
		Date Issued	22-Jan-15

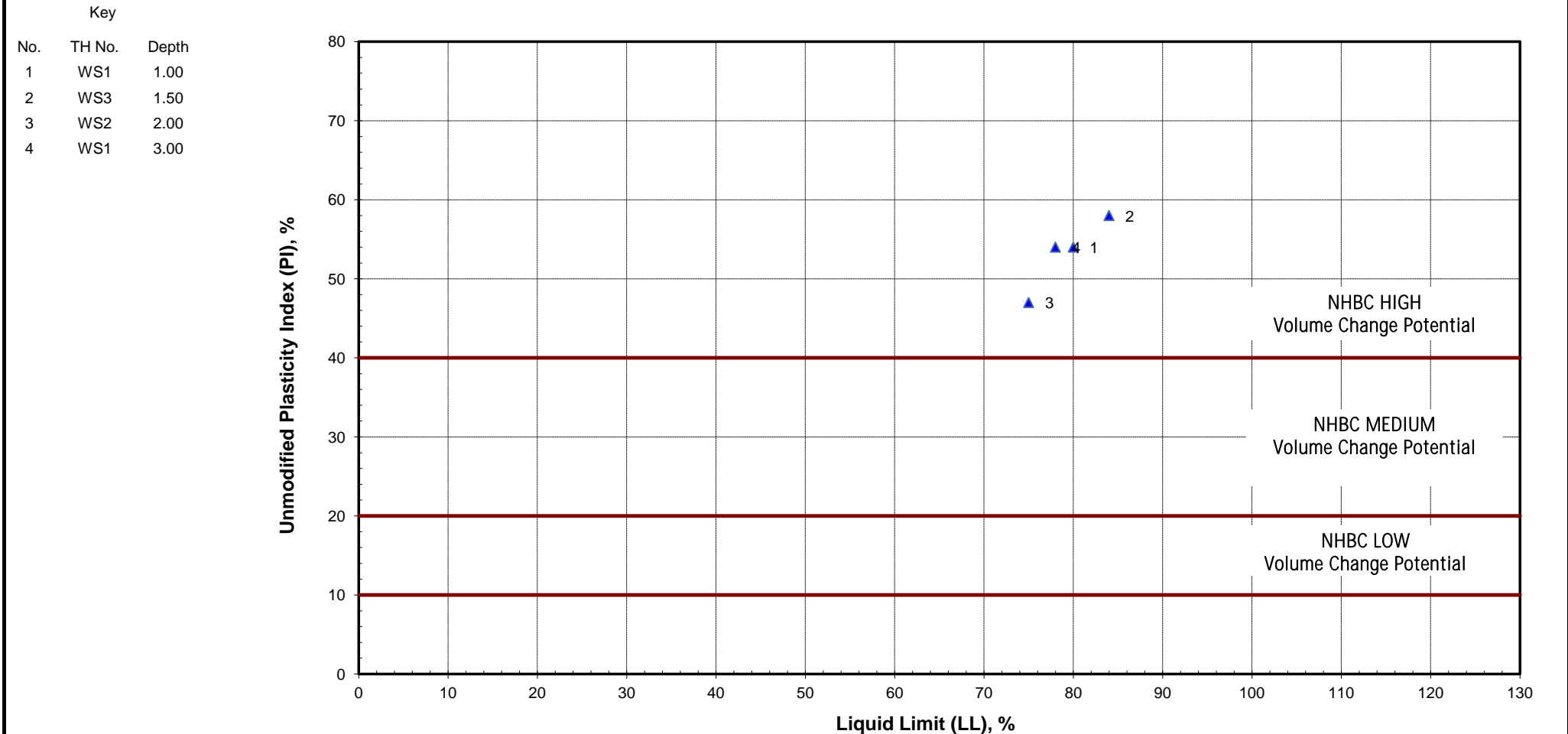

Project Name		The Admiral Mann PH (London N7)					Project Number		J12113	
Client		Lyons O'Neill			PE	DV	Date Issued		22-Jan-15	
TH No.	Depth m	Sample Type	Visual Description	Comments	Passing 2mm %	pH Value	Soil Sulphate 2:1 Water Extract		Groundwater Sulphate	
							g/l SO ₃	BRE mg/l SO ₄	g/l SO ₃	BRE mg/l SO ₄
WS2	1.50	D	Stiff high strength light brown CLAY.		100.0	7.6	1.68	2016		
WS3	1.50	D	Stiff high strength brown CLAY.		100.0	8.2	0.10	125		
WS1	2.00	D	Stiff high strength light brown CLAY.		100.0	7.6	2.08	2496		

Southern Testing Laboratories Limited, East Grinstead is registered under BS EN ISO 9001:2008 FS29280

Jun 13

Page: 1

APPENDIX D

Contamination Laboratory Test Results

Table 1 – Tier 1 Screening Values

Contaminant	Units	Proposed Land Use					
		Residential with homegrown produce consumption	Residential without homegrown produce consumption	Open Space* (Residential)	Open Space* (Park)	Allotments	Commercial / Industrial
Arsenic (As) [2]	mg/kg	37	40	79	170	43	640
Cadmium (Cd) [2]	mg/kg	11	85	120	532	1.9	190
Trivalent Chromium (CrIII) [2]	mg/kg	910	910	1,500	33,000	18,000	8600
Hexavalent Chromium (CrVI) [2]	mg/kg	6	6	7.7	220	1.8	33
Lead (Pb) [3]	mg/kg	200	310	630	1300	80	2330
Mercury (Hg) [1,2,7]	mg/kg	7.6-11	9.2-15	40	68-71	6.0	29-320
Selenium (Se) [2]	mg/kg	250	430	1,100	1,800	88	12,000
Nickel (Ni) [2,4]	mg/kg	180	180	230	3,400	230	980
Copper (Cu) [2,4]	mg/kg	2,400	7,100	12,000	44,000	520	68,000
Zinc (Zn) [2,4]	mg/kg	3,700	40,000	81,000	170,000	620	730,000
Phenol [1,2]	mg/kg	280-1100	750-2300	760-3200	760-3200	66-280	760-3200
Benzo[a]pyrene [1,5]	mg/kg	1.7-2.4	2.6	4.9	10	0.67-2.7	36
Naphthalene [1,2]	mg/kg	2.3-13	2.3-13	77-430 ⁺	77-430 ⁺	4.1-24	77-430 ⁺
Total Cyanide (CN) [6]	mg/kg	/	/	/	/	/	/
Free Cyanide [6]	mg/kg	/	/	/	/	/	/
Complex Cyanides [6]	mg/kg	/	/	/	/	/	/
Thiocyanate [6]	mg/kg	/	/	/	/	/	/

Notes:

* Open Space levels calculated on the basis of the exposure modelling developed in the C4SL research.

+ Screening values constrained to saturation limit. Higher values may be acceptable on a site specific basis.

[1] Where ranges of values are given for organic contaminants the screening value is dependant on the Soil ⁺Organic Matter.

[2] LQM/CIEH S4UL (2014). Copyright Land Quality Management Ltd reproduced with permission; Publication Number S4UL 3116. All rights reserved.

[3] C4SL (DEFRA 2014).

[4] Copper, Zinc and Nickel may have phototoxic effects at the given concentrations. Alternative criteria should be adopted for importation of Topsoil or other soils for cultivation. BS3882:2007 and BS8601:2013 suggest values of 200 to 300mg/kg for Zn, 100 to 200mg/kg for Cu, and 60 to 110mg/kg for Ni, for topsoil and subsoil, depending on pH.

[5] Based on the Surrogate Marker approach and modelled using the modified exposure parameters of C4SL but retaining 'minimal risk' HCV.

[6] Screening criteria derived on a site specific basis if test results indicate.

[7] S4UL for Methyl Mercury, higher concentrations may be tolerable if inorganic mercury is the only species present. Lower concentrations apply for elemental Mercury.

These screening values are valid at the time of writing but may be subject to change and any such changes will have implications for the assessments based on them. Their validity should be confirmed at the time of site development.



Scientific Analysis Laboratories Ltd

Certificate of Analysis

3 Crittall Drive
Springwood Industrial
Estate
Braintree
Essex
CM7 2RT
Tel : 01376 560120
Fax : 01376 552923

Scientific Analysis Laboratories is a
limited company registered in England and
Wales (No 2514788) whose address is at
Hadfield House, Hadfield Street, Manchester M16 9FE

Report Number: 449455-1

Date of Report: 27-Jan-2015

Customer: Southern Testing Laboratories
Keeble House
Stuart Way
East Grinstead
West Sussex
RH19 4QA

Customer Contact: Mr David Vooght

Customer Job Reference: J12113

Customer Purchase Order: J12113_1

Customer Site Reference: The Admiral Mann PH (London N7)

Date Job Received at SAL: 19-Jan-2015

Date Analysis Started: 20-Jan-2015

Date Analysis Completed: 27-Jan-2015

The results reported relate to samples received in the laboratory
Opinions and interpretations expressed herein are outside the scope of UKAS accreditation
This report should not be reproduced except in full without the written approval of the laboratory
Tests covered by this certificate were conducted in accordance with SAL SOPs
All results have been reviewed in accordance with QP22



Report checked
and authorised by :
Miss Claire Brown
Customer Service Manager

Issued by :
Miss Claire Brown
Customer Service Manager

SAL Reference: 449455							
Project Site: The Admiral Mann PH (London N7)							
Customer Reference: J12113							
Soil							
Analysed as Soil							
STL Key Contamination Suite							
SAL Reference				449455 001	449455 002	449455 003	
Customer Sample Reference				WS1 @ 0.30m	WS2 @ 0.45m	WS2 @ 0.60m	
Date Sampled				13-JAN-2015	13-JAN-2015	13-JAN-2015	
Type				Fill	Fill	Clay	
Determinand	Method	Test Sample	LOD	Units			
Arsenic	T257	A40	2.0	mg/kg	13	15	7
Cadmium	T257	A40	0.1	mg/kg	0.2	0.2	<0.1
Chromium	T257	A40	0.5	mg/kg	23	24	39
Copper	T257	A40	2	mg/kg	41	49	30
Lead	T257	A40	2	mg/kg	320	780	140
Mercury	T245	A40	1.0	mg/kg	<1.0	2.4	<1.0
Nickel	T257	A40	0.5	mg/kg	17	21	39
Selenium	T257	A40	3	mg/kg	<3	<3	<3
Zinc	T257	A40	2	mg/kg	140	170	79
Asbestos ID	T27	A40			Asbestos not detected	Asbestos not detected	-
Chromium VI	T6	A40	1	mg/kg	<1	<1	<1
Fraction Organic Carbon - F(oc)	T21	A40	1	%	<1	<1	<1
Soil Organic Matter	T287	A40	0.1	%	1.6	2.2	0.3
(Water Soluble) SO4-- expressed as SO4	T242	A40	0.01	g/l	0.10	0.56	0.26
pH	T7	A40			10.2	8.7	8.4
Sulphide	T4	A40	10	mg/kg	<10	87	<10
Cyanide(Total)	T4	AR	1	mg/kg	<1	<1	<1
Phenols(Mono)	T221	AR	1.0	mg/kg	<1.0	<1.0	<1.0

SAL Reference: 449455							
Project Site: The Admiral Mann PH (London N7)							
Customer Reference: J12113							
Soil							
Analysed as Soil							
Total and Speciated USEPA16 PAH (SE) (MCERTS)							
SAL Reference				449455 001	449455 002	449455 003	
Customer Sample Reference				WS1 @ 0.30m	WS2 @ 0.45m	WS2 @ 0.60m	
Date Sampled				13-JAN-2015	13-JAN-2015	13-JAN-2015	
Type				Fill	Fill	Clay	
Determinand	Method	Test Sample	LOD	Units			
Naphthalene	T16	AR	0.1	mg/kg	<0.1	0.5	<0.1
Acenaphthylene	T16	AR	0.1	mg/kg	<0.1	<0.1	<0.1
Acenaphthene	T16	AR	0.1	mg/kg	<0.1	0.6	<0.1
Fluorene	T16	AR	0.1	mg/kg	<0.1	0.6	<0.1
Phenanthrene	T16	AR	0.1	mg/kg	0.3	1.2	0.1
Anthracene	T16	AR	0.1	mg/kg	<0.1	0.2	<0.1
Fluoranthene	T16	AR	0.1	mg/kg	0.6	0.6	0.3
Pyrene	T16	AR	0.1	mg/kg	0.5	0.4	0.3
Benzo(a)Anthracene	T16	AR	0.1	mg/kg	0.2	0.2	0.1
Chrysene	T16	AR	0.1	mg/kg	0.2	0.2	0.1
Benzo(b)fluoranthene	T16	AR	0.1	mg/kg	0.2	0.1	<0.1
Benzo(k)fluoranthene	T16	AR	0.1	mg/kg	0.2	0.1	<0.1
Benzo(a)Pyrene	T16	AR	0.1	mg/kg	0.2	0.1	<0.1
Indeno(123-cd)Pyrene	T16	AR	0.1	mg/kg	<0.1	<0.1	<0.1
Dibenzo(ah)Anthracene	T16	AR	0.1	mg/kg	<0.1	<0.1	<0.1
Benzo(ghi)Perylene	T16	AR	0.1	mg/kg	<0.1	<0.1	<0.1
PAH(total)	T16	AR	0.1	mg/kg	2.4	4.8	1.2

Method Index

Value	Description
T245	ICP/OES(Aqua Regia Extraction)
T27	PLM
T2	Grav
T162	Grav (1 Dec) (105 C)
T4	Colorimetry
T209	GC/MS(Head Space)(MCERTS)
T6	ICP/OES
T54	GC/MS (Headspace)
T287	Calc TOC/0.58
T16	GC/MS
T219	GC/FID (SE)
T21	OX/IR
T221	Colorimetry (CE)
T242	2:1 Extraction/ICP/OES (TRL 447 T1)
T7	Probe
T257	ICP/OES (SIM) (Aqua Regia Extraction)

Accreditation Summary

Determinand	Method	Test Sample	LOD	Units	Symbol	SAL References
Moisture @ 105 C	T162	AR	0.1	%	N	001-004
Retained on 2mm	T2	A40	0.1	%	N	001-004
Arsenic	T257	A40	2.0	mg/kg	U	001-002
Arsenic	T257	A40	2	mg/kg	M	003
Cadmium	T257	A40	0.1	mg/kg	U	001-002
Cadmium	T257	A40	0.1	mg/kg	M	003
Chromium	T257	A40	0.5	mg/kg	U	001-002
Chromium	T257	A40	0.5	mg/kg	M	003
Copper	T257	A40	2	mg/kg	U	001-002
Copper	T257	A40	2	mg/kg	M	003
Lead	T257	A40	2	mg/kg	U	001-002
Lead	T257	A40	2	mg/kg	M	003
Mercury	T245	A40	1.0	mg/kg	U	001-003
Nickel	T257	A40	0.5	mg/kg	U	001-002
Nickel	T257	A40	0.5	mg/kg	M	003
Selenium	T257	A40	3	mg/kg	U	001-003
Zinc	T257	A40	2	mg/kg	U	001-002
Zinc	T257	A40	2	mg/kg	M	003
Asbestos ID	T27	A40			SU	001-002
Chromium VI	T6	A40	1	mg/kg	N	001-003
Fraction Organic Carbon - F(oc)	T21	A40	1	%	WN	001-003
Soil Organic Matter	T287	A40	0.1	%	WN	001-003
(Water Soluble) SO4-- expressed as SO4	T242	A40	0.01	g/l	U	001-002
(Water Soluble) SO4-- expressed as SO4	T242	A40	0.01	g/l	M	003
pH	T7	A40			U	001-002
pH	T7	A40			M	003
Sulphide	T4	A40	10	mg/kg	N	001-003
Cyanide(Total)	T4	AR	1	mg/kg	U	001-002
Cyanide(Total)	T4	AR	1	mg/kg	M	003
Phenols(Mono)	T221	AR	1.0	mg/kg	U	001-002
Phenols(Mono)	T221	AR	1.0	mg/kg	M	003
Naphthalene	T16	AR	0.1	mg/kg	U	001-003
Acenaphthylene	T16	AR	0.1	mg/kg	U	001-003
Acenaphthene	T16	AR	0.1	mg/kg	U	001-002
Acenaphthene	T16	AR	0.1	mg/kg	M	003
Fluorene	T16	AR	0.1	mg/kg	U	001-002
Fluorene	T16	AR	0.1	mg/kg	M	003
Phenanthrene	T16	AR	0.1	mg/kg	U	001-003
Anthracene	T16	AR	0.1	mg/kg	U	001-002
Anthracene	T16	AR	0.1	mg/kg	M	003
Fluoranthene	T16	AR	0.1	mg/kg	N	001-003
Pyrene	T16	AR	0.1	mg/kg	N	001-003
Benzo(a)Anthracene	T16	AR	0.1	mg/kg	U	001-002
Benzo(a)Anthracene	T16	AR	0.1	mg/kg	M	003
Chrysene	T16	AR	0.1	mg/kg	U	001-002
Chrysene	T16	AR	0.1	mg/kg	M	003

Determinand	Method	Test Sample	LOD	Units	Symbol	SAL References
Benzo(b)fluoranthene	T16	AR	0.1	mg/kg	U	001-003
Benzo(k)fluoranthene	T16	AR	0.1	mg/kg	N	001-003
Benzo(a)Pyrene	T16	AR	0.1	mg/kg	U	001-002
Benzo(a)Pyrene	T16	AR	0.1	mg/kg	M	003
Indeno(123-cd)Pyrene	T16	AR	0.1	mg/kg	U	001-002
Indeno(123-cd)Pyrene	T16	AR	0.1	mg/kg	M	003
Dibenzo(ah)Anthracene	T16	AR	0.1	mg/kg	U	001-002
Dibenzo(ah)Anthracene	T16	AR	0.1	mg/kg	M	003
Benzo(ghi)Perylene	T16	AR	0.1	mg/kg	U	001-002
Benzo(ghi)Perylene	T16	AR	0.1	mg/kg	M	003
PAH(total)	T16	AR	0.1	mg/kg	U	001-003
Benzene	T209	AR	10	µg/kg	M	004
EthylBenzene	T209	AR	10	µg/kg	M	004
M/P Xylene	T209	AR	10	µg/kg	M	004
O Xylene	T209	AR	10	µg/kg	M	004
Toluene	T209	AR	10	µg/kg	M	004
Methyl tert-Butyl Ether	T209	AR	10	µg/kg	M	004
TPH (C5-C6 aliphatic)	T54	AR	0.10	mg/kg	N	004
TPH (C6-C7 aromatic)	T54	AR	0.10	mg/kg	N	004
TPH (C6-C8 aliphatic)	T54	AR	0.10	mg/kg	N	004
TPH (C7-C8 aromatic)	T54	AR	0.10	mg/kg	N	004
TPH (C8-C10 aliphatic)	T54	AR	0.10	mg/kg	N	004
TPH (C8-C10 aromatic)	T54	AR	0.10	mg/kg	N	004
TPH (C10-C12 aliphatic)	T219	AR	2	mg/kg	WN	004
TPH (C10-C12 aromatic)	T219	AR	2	mg/kg	WN	004
TPH (C12-C16 aliphatic)	T219	AR	2	mg/kg	WN	004
TPH (C12-C16 aromatic)	T219	AR	2	mg/kg	WN	004
TPH (C16-C21 aliphatic)	T219	AR	2	mg/kg	WN	004
TPH (C16-C21 aromatic)	T219	AR	2	mg/kg	WN	004
TPH (C21-C35 aliphatic)	T219	AR	2	mg/kg	WN	004
TPH (C21-C35 aromatic)	T219	AR	2	mg/kg	WN	004



APPENDIX E

Bomb Map

MAP 38

Colour Key References
(for guidance only)

- Black**
Total destruction
- Purple**
Damaged beyond repair
- Dark Red**
Seriously damaged; doubtful if repairable
- Light Red**
Seriously damaged, but repairable at cost
- Orange**
General blast damage – not structural
- Yellow**
Blast damage, minor in nature
- Light Blue**
Clearance areas
- Light Green**
Clearance areas

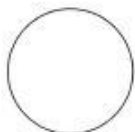

V1 flying bomb



V2 long range rocket



Site: Admiral Mann Public House, 9 Hargrave Place (London N7)

STL: J12113

Fig No: A

Date: 16 January 2015

Bomb Map

APPENDIX F

PDISP Output for Heave Displacements

Job No.	Sheet No.	Rev.
J12113		
Drg. Ref.		
Made by	Date	Checked
	26-Jan-2015	

Settlement Contours : Grid 1 at -2.520m

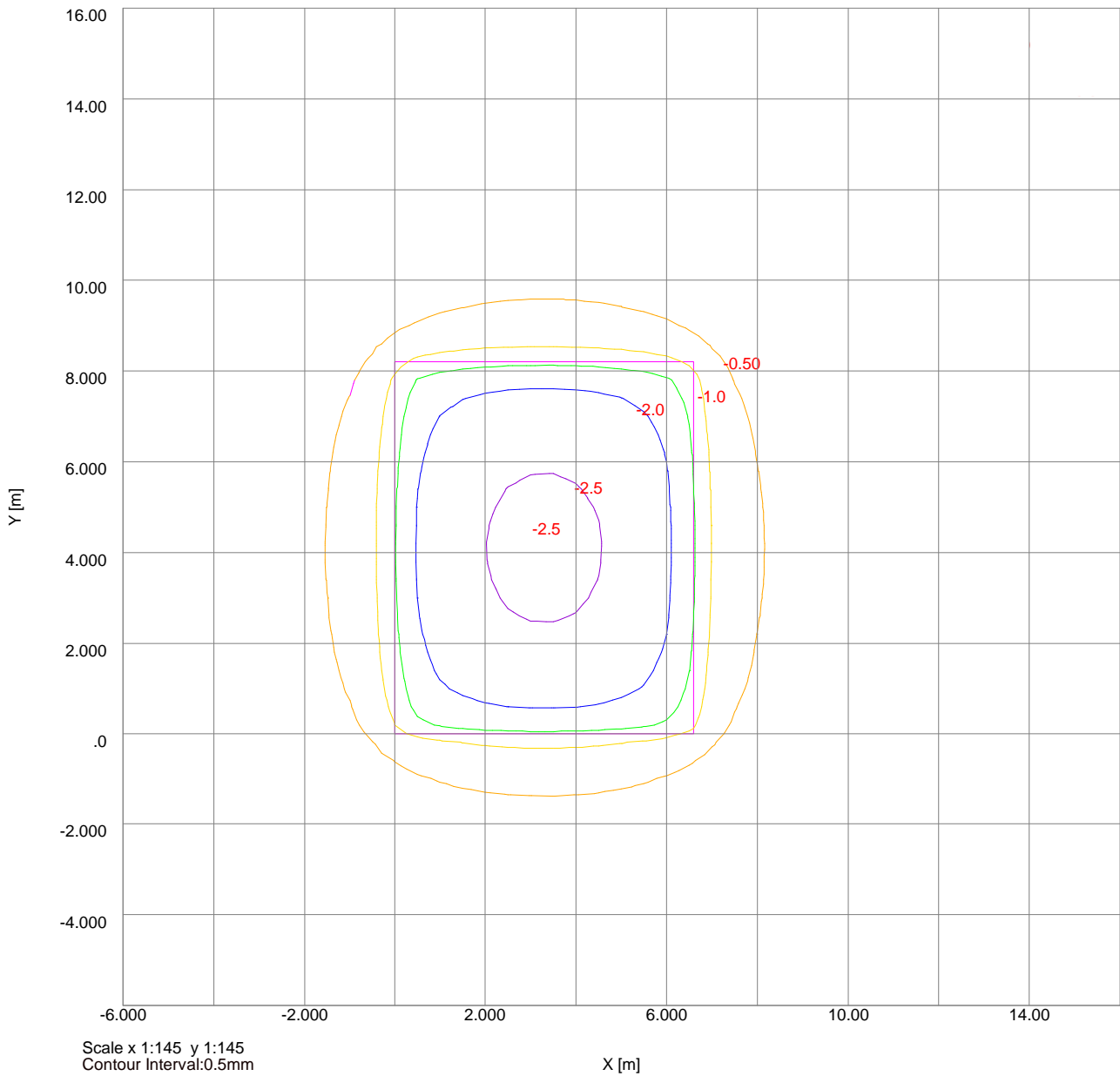

Settlement Contours : Grid 1 at -2.520m

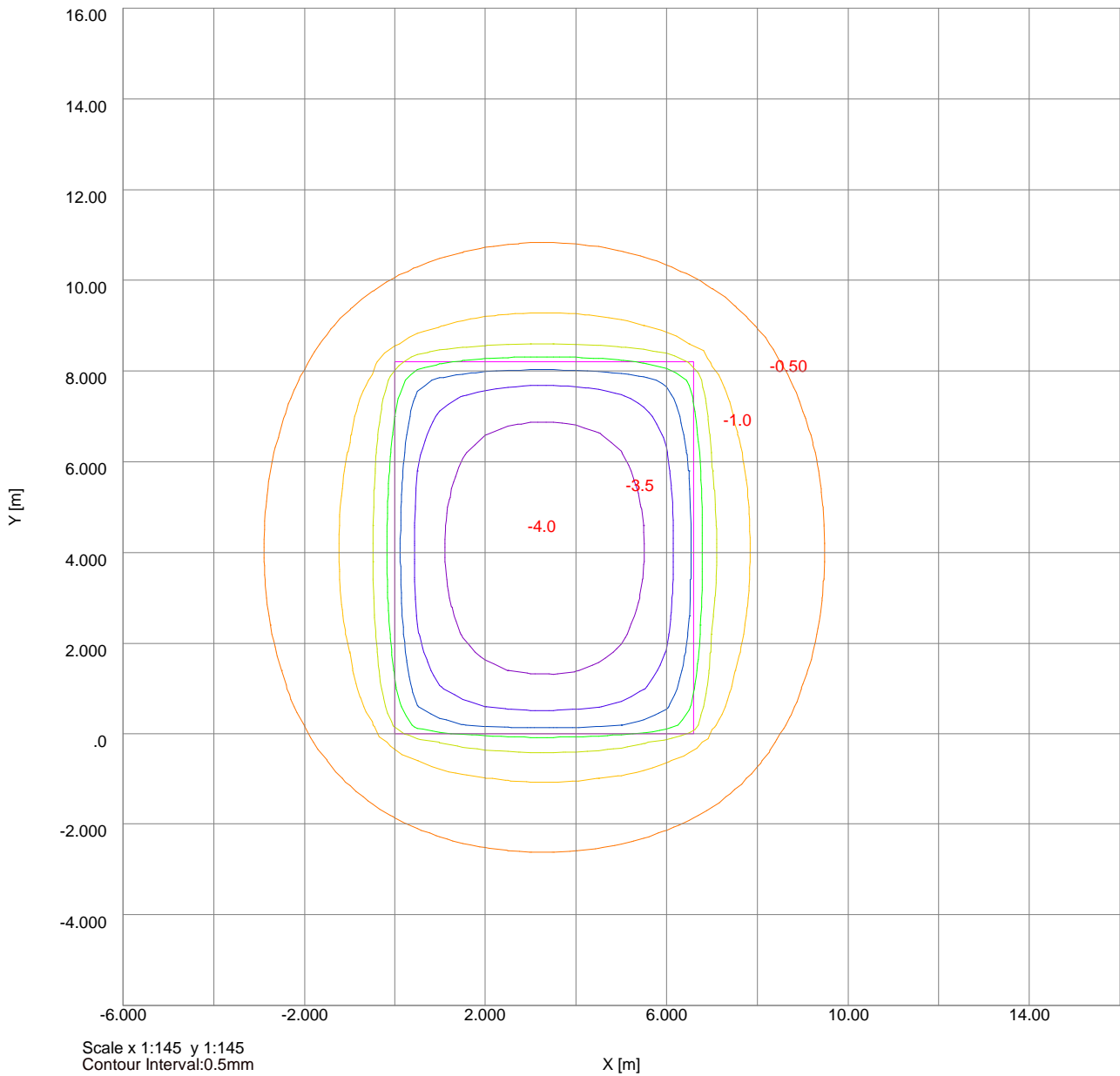

Scale x 1:145 y 1:145
Contour Interval:0.5mm

X [m]