

## **A8. PEDESTRIAN CROSSING SURVEY**

**TSUK**

Gordon St, London

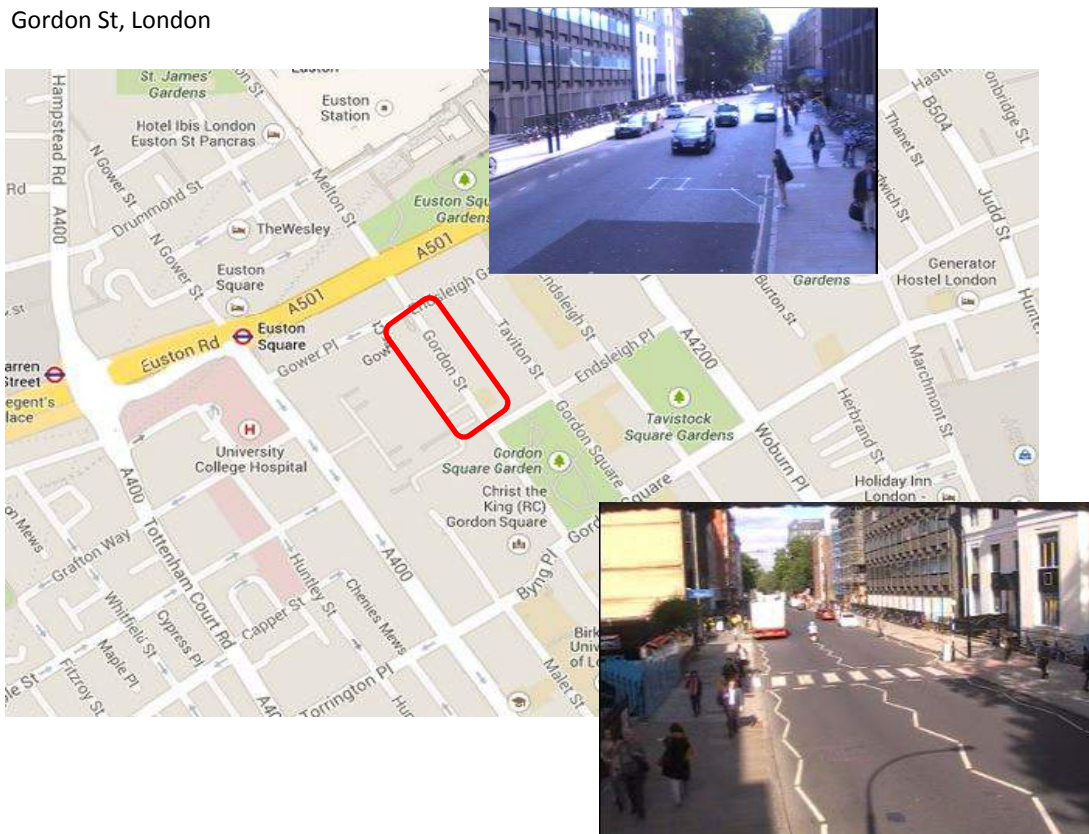

**Client** ICENI PROJECTS

**Survey Dates and Times** Tuesday 08 October 2013  
0700 - 1900

**Survey Method** Video **Weather** Dry

**Class** Zonal + College Entrance - Pedestrian count, no classification  
Service Entrance - PC / MC / CAR / LGV / OGV1 / OGV2 / PSV

**Observations**

TSUK

Gordon St, London

User-Specified, Time-Based Flow Diagram

Survey Date:

Tuesday 08 October 2013

Time Specified:  
(Select)

- 0730 - 0830
- 0745 - 0845
- 0800 - 0900
- 0815 - 0915
- 0830 - 0930
- 0845 - 0945

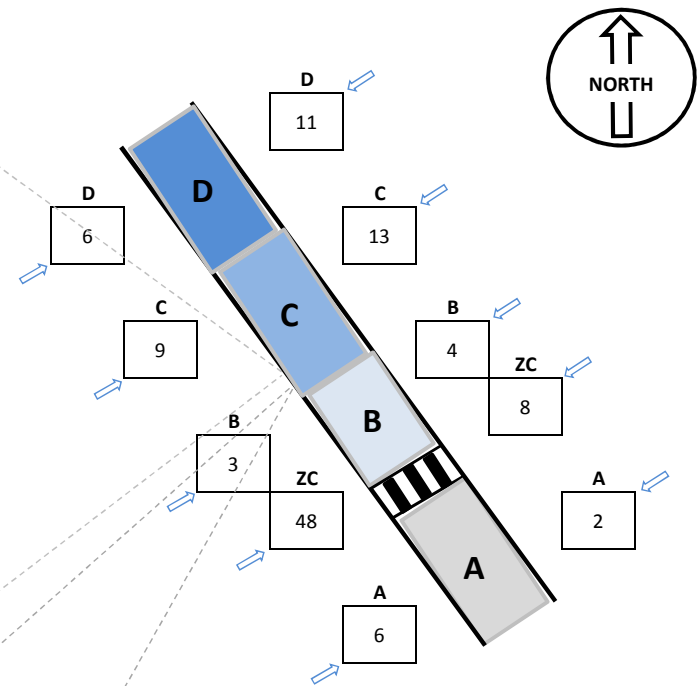
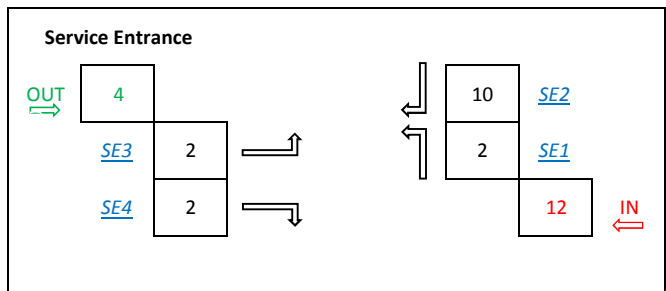
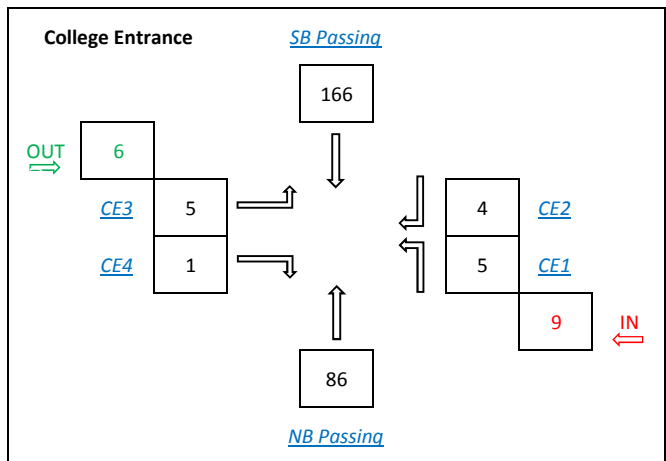

- Zone A- Crossing Zig-Zag markings
- Zone B - crossing Zig-Zag markings
- Zone C - crossing 20m section
- Zone D - Crossing 20m section

**TSUK**

Gordon St, London  
 Tuesday 08 October 2013  
**15 Minute and Hourly**

**Zone A**

| Zone A      |   |             |    |             |   |             |    |
|-------------|---|-------------|----|-------------|---|-------------|----|
| Eastbound   |   |             |    | Westbound   |   |             |    |
| 15 minute   |   | Hourly      |    | 15 minute   |   | Hourly      |    |
| 0700 - 0715 | 0 | 0700 - 0800 | 6  | 0700 - 0715 | 0 | 0700 - 0800 | 2  |
| 0715 - 0730 | 2 | 0715 - 0815 | 7  | 0715 - 0730 | 0 | 0715 - 0815 | 2  |
| 0730 - 0745 | 1 | 0730 - 0830 | 7  | 0730 - 0745 | 1 | 0730 - 0830 | 2  |
| 0745 - 0800 | 3 | 0745 - 0845 | 11 | 0745 - 0800 | 1 | 0745 - 0845 | 1  |
| 0800 - 0815 | 1 | 0800 - 0900 | 14 | 0800 - 0815 | 0 | 0800 - 0900 | 0  |
| 0815 - 0830 | 2 | 0815 - 0915 | 16 | 0815 - 0830 | 0 | 0815 - 0915 | 0  |
| 0830 - 0845 | 5 | 0830 - 0930 | 19 | 0830 - 0845 | 0 | 0830 - 0930 | 1  |
| 0845 - 0900 | 6 | 0845 - 0945 | 19 | 0845 - 0900 | 0 | 0845 - 0945 | 1  |
| 0900 - 0915 | 3 | 0900 - 1000 | 16 | 0900 - 0915 | 0 | 0900 - 1000 | 1  |
| 0915 - 0930 | 5 | 0915 - 1015 | 16 | 0915 - 0930 | 1 | 0915 - 1015 | 1  |
| 0930 - 0945 | 5 | 0930 - 1030 | 11 | 0930 - 0945 | 0 | 0930 - 1030 | 0  |
| 0945 - 1000 | 3 | 0945 - 1045 | 7  | 0945 - 1000 | 0 | 0945 - 1045 | 0  |
| 1000 - 1015 | 3 | 1000 - 1100 | 5  | 1000 - 1015 | 0 | 1000 - 1100 | 1  |
| 1015 - 1030 | 0 | 1015 - 1115 | 3  | 1015 - 1030 | 0 | 1015 - 1115 | 1  |
| 1030 - 1045 | 1 | 1030 - 1130 | 6  | 1030 - 1045 | 0 | 1030 - 1130 | 2  |
| 1045 - 1100 | 1 | 1045 - 1145 | 5  | 1045 - 1100 | 1 | 1045 - 1145 | 4  |
| 1100 - 1115 | 1 | 1100 - 1200 | 6  | 1100 - 1115 | 0 | 1100 - 1200 | 3  |
| 1115 - 1130 | 3 | 1115 - 1215 | 11 | 1115 - 1130 | 1 | 1115 - 1215 | 4  |
| 1130 - 1145 | 0 | 1130 - 1230 | 9  | 1130 - 1145 | 2 | 1130 - 1230 | 4  |
| 1145 - 1200 | 2 | 1145 - 1245 | 14 | 1145 - 1200 | 0 | 1145 - 1245 | 2  |
| 1200 - 1215 | 6 | 1200 - 1300 | 18 | 1200 - 1215 | 1 | 1200 - 1300 | 2  |
| 1215 - 1230 | 1 | 1215 - 1315 | 18 | 1215 - 1230 | 1 | 1215 - 1315 | 1  |
| 1230 - 1245 | 5 | 1230 - 1330 | 20 | 1230 - 1245 | 0 | 1230 - 1330 | 1  |
| 1245 - 1300 | 6 | 1245 - 1345 | 16 | 1245 - 1300 | 0 | 1245 - 1345 | 1  |
| 1300 - 1315 | 6 | 1300 - 1400 | 18 | 1300 - 1315 | 0 | 1300 - 1400 | 1  |
| 1315 - 1330 | 3 | 1315 - 1415 | 13 | 1315 - 1330 | 1 | 1315 - 1415 | 4  |
| 1330 - 1345 | 1 | 1330 - 1430 | 15 | 1330 - 1345 | 0 | 1330 - 1430 | 3  |
| 1345 - 1400 | 8 | 1345 - 1445 | 18 | 1345 - 1400 | 0 | 1345 - 1445 | 5  |
| 1400 - 1415 | 1 | 1400 - 1500 | 14 | 1400 - 1415 | 3 | 1400 - 1500 | 5  |
| 1415 - 1430 | 5 | 1415 - 1515 | 18 | 1415 - 1430 | 0 | 1415 - 1515 | 4  |
| 1430 - 1445 | 4 | 1430 - 1530 | 14 | 1430 - 1445 | 2 | 1430 - 1530 | 4  |
| 1445 - 1500 | 4 | 1445 - 1545 | 13 | 1445 - 1500 | 0 | 1445 - 1545 | 3  |
| 1500 - 1515 | 5 | 1500 - 1600 | 14 | 1500 - 1515 | 2 | 1500 - 1600 | 4  |
| 1515 - 1530 | 1 | 1515 - 1615 | 12 | 1515 - 1530 | 0 | 1515 - 1615 | 2  |
| 1530 - 1545 | 3 | 1530 - 1630 | 11 | 1530 - 1545 | 1 | 1530 - 1630 | 2  |
| 1545 - 1600 | 5 | 1545 - 1645 | 9  | 1545 - 1600 | 1 | 1545 - 1645 | 2  |
| 1600 - 1615 | 3 | 1600 - 1700 | 7  | 1600 - 1615 | 0 | 1600 - 1700 | 2  |
| 1615 - 1630 | 0 | 1615 - 1715 | 7  | 1615 - 1630 | 0 | 1615 - 1715 | 3  |
| 1630 - 1645 | 1 | 1630 - 1730 | 8  | 1630 - 1645 | 1 | 1630 - 1730 | 4  |
| 1645 - 1700 | 3 | 1645 - 1745 | 9  | 1645 - 1700 | 1 | 1645 - 1745 | 9  |
| 1700 - 1715 | 3 | 1700 - 1800 | 11 | 1700 - 1715 | 1 | 1700 - 1800 | 11 |
| 1715 - 1730 | 1 | 1715 - 1815 | 10 | 1715 - 1730 | 1 | 1715 - 1815 | 10 |
| 1730 - 1745 | 2 | 1730 - 1830 | 10 | 1730 - 1745 | 6 | 1730 - 1830 | 10 |
| 1745 - 1800 | 5 | 1745 - 1845 | 8  | 1745 - 1800 | 3 | 1745 - 1845 | 4  |
| 1800 - 1815 | 2 | 1800 - 1900 | 3  | 1800 - 1815 | 0 | 1800 - 1900 | 2  |
| 1815 - 1830 | 1 |             |    | 1815 - 1830 | 1 |             |    |
| 1830 - 1845 | 0 |             |    | 1830 - 1845 | 0 |             |    |
| 1845 - 1900 | 0 |             |    | 1845 - 1900 | 1 |             |    |

**TSUK**

Gordon St, London  
 Tuesday 08 October 2013  
**15 Minute and Hourly**

**Zebra Crossing**

| Zebra Crossing |     |             |     |             |     |             |     |
|----------------|-----|-------------|-----|-------------|-----|-------------|-----|
| Eastbound      |     |             |     | Westbound   |     |             |     |
| 15 minute      |     | Hourly      |     | 15 minute   |     | Hourly      |     |
| 0700 - 0715    | 9   | 0700 - 0800 | 48  | 0700 - 0715 | 3   | 0700 - 0800 | 8   |
| 0715 - 0730    | 10  | 0715 - 0815 | 63  | 0715 - 0730 | 0   | 0715 - 0815 | 12  |
| 0730 - 0745    | 10  | 0730 - 0830 | 103 | 0730 - 0745 | 1   | 0730 - 0830 | 25  |
| 0745 - 0800    | 19  | 0745 - 0845 | 159 | 0745 - 0800 | 4   | 0745 - 0845 | 52  |
| 0800 - 0815    | 24  | 0800 - 0900 | 283 | 0800 - 0815 | 7   | 0800 - 0900 | 124 |
| 0815 - 0830    | 50  | 0815 - 0915 | 365 | 0815 - 0830 | 13  | 0815 - 0915 | 176 |
| 0830 - 0845    | 66  | 0830 - 0930 | 397 | 0830 - 0845 | 28  | 0830 - 0930 | 182 |
| 0845 - 0900    | 143 | 0845 - 0945 | 390 | 0845 - 0900 | 76  | 0845 - 0945 | 190 |
| 0900 - 0915    | 106 | 0900 - 1000 | 341 | 0900 - 0915 | 59  | 0900 - 1000 | 205 |
| 0915 - 0930    | 82  | 0915 - 1015 | 313 | 0915 - 0930 | 19  | 0915 - 1015 | 286 |
| 0930 - 0945    | 59  | 0930 - 1030 | 353 | 0930 - 0945 | 36  | 0930 - 1030 | 326 |
| 0945 - 1000    | 94  | 0945 - 1045 | 351 | 0945 - 1000 | 91  | 0945 - 1045 | 360 |
| 1000 - 1015    | 78  | 1000 - 1100 | 424 | 1000 - 1015 | 140 | 1000 - 1100 | 377 |
| 1015 - 1030    | 122 | 1015 - 1115 | 542 | 1015 - 1030 | 59  | 1015 - 1115 | 328 |
| 1030 - 1045    | 57  | 1030 - 1130 | 485 | 1030 - 1045 | 70  | 1030 - 1130 | 330 |
| 1045 - 1100    | 167 | 1045 - 1145 | 509 | 1045 - 1100 | 108 | 1045 - 1145 | 304 |
| 1100 - 1115    | 196 | 1100 - 1200 | 452 | 1100 - 1115 | 91  | 1100 - 1200 | 258 |
| 1115 - 1130    | 65  | 1115 - 1215 | 361 | 1115 - 1130 | 61  | 1115 - 1215 | 226 |
| 1130 - 1145    | 81  | 1130 - 1230 | 387 | 1130 - 1145 | 44  | 1130 - 1230 | 298 |
| 1145 - 1200    | 110 | 1145 - 1245 | 385 | 1145 - 1200 | 62  | 1145 - 1245 | 394 |
| 1200 - 1215    | 105 | 1200 - 1300 | 526 | 1200 - 1215 | 59  | 1200 - 1300 | 543 |
| 1215 - 1230    | 91  | 1215 - 1315 | 737 | 1215 - 1230 | 133 | 1215 - 1315 | 666 |
| 1230 - 1245    | 79  | 1230 - 1330 | 775 | 1230 - 1245 | 140 | 1230 - 1330 | 663 |
| 1245 - 1300    | 251 | 1245 - 1345 | 910 | 1245 - 1300 | 211 | 1245 - 1345 | 658 |
| 1300 - 1315    | 316 | 1300 - 1400 | 855 | 1300 - 1315 | 182 | 1300 - 1400 | 677 |
| 1315 - 1330    | 129 | 1315 - 1415 | 733 | 1315 - 1330 | 130 | 1315 - 1415 | 650 |
| 1330 - 1345    | 214 | 1330 - 1430 | 678 | 1330 - 1345 | 135 | 1330 - 1430 | 604 |
| 1345 - 1400    | 196 | 1345 - 1445 | 528 | 1345 - 1400 | 230 | 1345 - 1445 | 527 |
| 1400 - 1415    | 194 | 1400 - 1500 | 430 | 1400 - 1415 | 155 | 1400 - 1500 | 403 |
| 1415 - 1430    | 74  | 1415 - 1515 | 360 | 1415 - 1430 | 84  | 1415 - 1515 | 368 |
| 1430 - 1445    | 64  | 1430 - 1530 | 389 | 1430 - 1445 | 58  | 1430 - 1530 | 359 |
| 1445 - 1500    | 98  | 1445 - 1545 | 404 | 1445 - 1500 | 106 | 1445 - 1545 | 406 |
| 1500 - 1515    | 124 | 1500 - 1600 | 478 | 1500 - 1515 | 120 | 1500 - 1600 | 530 |
| 1515 - 1530    | 103 | 1515 - 1615 | 549 | 1515 - 1530 | 75  | 1515 - 1615 | 544 |
| 1530 - 1545    | 79  | 1530 - 1630 | 527 | 1530 - 1545 | 105 | 1530 - 1630 | 558 |
| 1545 - 1600    | 172 | 1545 - 1645 | 516 | 1545 - 1600 | 230 | 1545 - 1645 | 525 |
| 1600 - 1615    | 195 | 1600 - 1700 | 534 | 1600 - 1615 | 134 | 1600 - 1700 | 429 |
| 1615 - 1630    | 81  | 1615 - 1715 | 504 | 1615 - 1630 | 89  | 1615 - 1715 | 432 |
| 1630 - 1645    | 68  | 1630 - 1730 | 536 | 1630 - 1645 | 72  | 1630 - 1730 | 443 |
| 1645 - 1700    | 190 | 1645 - 1745 | 584 | 1645 - 1700 | 134 | 1645 - 1745 | 472 |
| 1700 - 1715    | 165 | 1700 - 1800 | 532 | 1700 - 1715 | 137 | 1700 - 1800 | 466 |
| 1715 - 1730    | 113 | 1715 - 1815 | 529 | 1715 - 1730 | 100 | 1715 - 1815 | 465 |
| 1730 - 1745    | 116 | 1730 - 1830 | 493 | 1730 - 1745 | 101 | 1730 - 1830 | 460 |
| 1745 - 1800    | 138 | 1745 - 1845 | 453 | 1745 - 1800 | 128 | 1745 - 1845 | 452 |
| 1800 - 1815    | 162 | 1800 - 1900 | 416 | 1800 - 1815 | 136 | 1800 - 1900 | 399 |
| 1815 - 1830    | 77  |             |     | 1815 - 1830 | 95  |             |     |
| 1830 - 1845    | 76  |             |     | 1830 - 1845 | 93  |             |     |
| 1845 - 1900    | 101 |             |     | 1845 - 1900 | 75  |             |     |

**TSUK**

Gordon St, London  
 Tuesday 08 October 2013  
**15 Minute and Hourly**

**Zone B**

| Zone B      |    |             |    |             |    |             |     |
|-------------|----|-------------|----|-------------|----|-------------|-----|
| Eastbound   |    |             |    | Westbound   |    |             |     |
| 15 minute   |    | Hourly      |    | 15 minute   |    | Hourly      |     |
| 0700 - 0715 | 1  | 0700 - 0800 | 3  | 0700 - 0715 | 3  | 0700 - 0800 | 4   |
| 0715 - 0730 | 1  | 0715 - 0815 | 4  | 0715 - 0730 | 0  | 0715 - 0815 | 1   |
| 0730 - 0745 | 0  | 0730 - 0830 | 4  | 0730 - 0745 | 0  | 0730 - 0830 | 1   |
| 0745 - 0800 | 1  | 0745 - 0845 | 9  | 0745 - 0800 | 1  | 0745 - 0845 | 1   |
| 0800 - 0815 | 2  | 0800 - 0900 | 11 | 0800 - 0815 | 0  | 0800 - 0900 | 9   |
| 0815 - 0830 | 1  | 0815 - 0915 | 18 | 0815 - 0830 | 0  | 0815 - 0915 | 20  |
| 0830 - 0845 | 5  | 0830 - 0930 | 23 | 0830 - 0845 | 0  | 0830 - 0930 | 29  |
| 0845 - 0900 | 3  | 0845 - 0945 | 24 | 0845 - 0900 | 9  | 0845 - 0945 | 32  |
| 0900 - 0915 | 9  | 0900 - 1000 | 36 | 0900 - 0915 | 11 | 0900 - 1000 | 33  |
| 0915 - 0930 | 6  | 0915 - 1015 | 37 | 0915 - 0930 | 9  | 0915 - 1015 | 32  |
| 0930 - 0945 | 6  | 0930 - 1030 | 43 | 0930 - 0945 | 3  | 0930 - 1030 | 26  |
| 0945 - 1000 | 15 | 0945 - 1045 | 40 | 0945 - 1000 | 10 | 0945 - 1045 | 35  |
| 1000 - 1015 | 10 | 1000 - 1100 | 41 | 1000 - 1015 | 10 | 1000 - 1100 | 68  |
| 1015 - 1030 | 12 | 1015 - 1115 | 54 | 1015 - 1030 | 3  | 1015 - 1115 | 126 |
| 1030 - 1045 | 3  | 1030 - 1130 | 51 | 1030 - 1045 | 12 | 1030 - 1130 | 129 |
| 1045 - 1100 | 16 | 1045 - 1145 | 54 | 1045 - 1100 | 43 | 1045 - 1145 | 120 |
| 1100 - 1115 | 23 | 1100 - 1200 | 42 | 1100 - 1115 | 68 | 1100 - 1200 | 87  |
| 1115 - 1130 | 9  | 1115 - 1215 | 26 | 1115 - 1130 | 6  | 1115 - 1215 | 37  |
| 1130 - 1145 | 6  | 1130 - 1230 | 23 | 1130 - 1145 | 3  | 1130 - 1230 | 46  |
| 1145 - 1200 | 4  | 1145 - 1245 | 20 | 1145 - 1200 | 10 | 1145 - 1245 | 56  |
| 1200 - 1215 | 7  | 1200 - 1300 | 39 | 1200 - 1215 | 18 | 1200 - 1300 | 66  |
| 1215 - 1230 | 6  | 1215 - 1315 | 61 | 1215 - 1230 | 15 | 1215 - 1315 | 73  |
| 1230 - 1245 | 3  | 1230 - 1330 | 60 | 1230 - 1245 | 13 | 1230 - 1330 | 62  |
| 1245 - 1300 | 23 | 1245 - 1345 | 63 | 1245 - 1300 | 20 | 1245 - 1345 | 57  |
| 1300 - 1315 | 29 | 1300 - 1400 | 56 | 1300 - 1315 | 25 | 1300 - 1400 | 58  |
| 1315 - 1330 | 5  | 1315 - 1415 | 45 | 1315 - 1330 | 4  | 1315 - 1415 | 58  |
| 1330 - 1345 | 6  | 1330 - 1430 | 44 | 1330 - 1345 | 8  | 1330 - 1430 | 65  |
| 1345 - 1400 | 16 | 1345 - 1445 | 40 | 1345 - 1400 | 21 | 1345 - 1445 | 65  |
| 1400 - 1415 | 18 | 1400 - 1500 | 32 | 1400 - 1415 | 25 | 1400 - 1500 | 57  |
| 1415 - 1430 | 4  | 1415 - 1515 | 29 | 1415 - 1430 | 11 | 1415 - 1515 | 43  |
| 1430 - 1445 | 2  | 1430 - 1530 | 33 | 1430 - 1445 | 8  | 1430 - 1530 | 36  |
| 1445 - 1500 | 8  | 1445 - 1545 | 36 | 1445 - 1500 | 13 | 1445 - 1545 | 41  |
| 1500 - 1515 | 15 | 1500 - 1600 | 40 | 1500 - 1515 | 11 | 1500 - 1600 | 55  |
| 1515 - 1530 | 8  | 1515 - 1615 | 40 | 1515 - 1530 | 4  | 1515 - 1615 | 60  |
| 1530 - 1545 | 5  | 1530 - 1630 | 41 | 1530 - 1545 | 13 | 1530 - 1630 | 60  |
| 1545 - 1600 | 12 | 1545 - 1645 | 39 | 1545 - 1600 | 27 | 1545 - 1645 | 52  |
| 1600 - 1615 | 15 | 1600 - 1700 | 34 | 1600 - 1615 | 16 | 1600 - 1700 | 33  |
| 1615 - 1630 | 9  | 1615 - 1715 | 32 | 1615 - 1630 | 4  | 1615 - 1715 | 33  |
| 1630 - 1645 | 3  | 1630 - 1730 | 27 | 1630 - 1645 | 5  | 1630 - 1730 | 35  |
| 1645 - 1700 | 7  | 1645 - 1745 | 27 | 1645 - 1700 | 8  | 1645 - 1745 | 38  |
| 1700 - 1715 | 13 | 1700 - 1800 | 31 | 1700 - 1715 | 16 | 1700 - 1800 | 37  |
| 1715 - 1730 | 4  | 1715 - 1815 | 36 | 1715 - 1730 | 6  | 1715 - 1815 | 33  |
| 1730 - 1745 | 3  | 1730 - 1830 | 37 | 1730 - 1745 | 8  | 1730 - 1830 | 36  |
| 1745 - 1800 | 11 | 1745 - 1845 | 36 | 1745 - 1800 | 7  | 1745 - 1845 | 37  |
| 1800 - 1815 | 18 | 1800 - 1900 | 30 | 1800 - 1815 | 12 | 1800 - 1900 | 38  |
| 1815 - 1830 | 5  |             |    | 1815 - 1830 | 9  |             |     |
| 1830 - 1845 | 2  |             |    | 1830 - 1845 | 9  |             |     |
| 1845 - 1900 | 5  |             |    | 1845 - 1900 | 8  |             |     |

**TSUK**

Gordon St, London  
 Tuesday 08 October 2013  
**15 Minute and Hourly**

**Zone C**

| Zone C      |    |             |     |             |     |             |     |
|-------------|----|-------------|-----|-------------|-----|-------------|-----|
| Eastbound   |    |             |     | Westbound   |     |             |     |
| 15 minute   |    | Hourly      |     | 15 minute   |     | Hourly      |     |
| 0700 - 0715 | 2  | 0700 - 0800 | 9   | 0700 - 0715 | 0   | 0700 - 0800 | 13  |
| 0715 - 0730 | 1  | 0715 - 0815 | 10  | 0715 - 0730 | 1   | 0715 - 0815 | 18  |
| 0730 - 0745 | 4  | 0730 - 0830 | 14  | 0730 - 0745 | 5   | 0730 - 0830 | 19  |
| 0745 - 0800 | 2  | 0745 - 0845 | 18  | 0745 - 0800 | 7   | 0745 - 0845 | 20  |
| 0800 - 0815 | 3  | 0800 - 0900 | 41  | 0800 - 0815 | 5   | 0800 - 0900 | 35  |
| 0815 - 0830 | 5  | 0815 - 0915 | 62  | 0815 - 0830 | 2   | 0815 - 0915 | 40  |
| 0830 - 0845 | 8  | 0830 - 0930 | 68  | 0830 - 0845 | 6   | 0830 - 0930 | 51  |
| 0845 - 0900 | 25 | 0845 - 0945 | 73  | 0845 - 0900 | 22  | 0845 - 0945 | 52  |
| 0900 - 0915 | 24 | 0900 - 1000 | 70  | 0900 - 0915 | 10  | 0900 - 1000 | 44  |
| 0915 - 0930 | 11 | 0915 - 1015 | 63  | 0915 - 0930 | 13  | 0915 - 1015 | 52  |
| 0930 - 0945 | 13 | 0930 - 1030 | 67  | 0930 - 0945 | 7   | 0930 - 1030 | 49  |
| 0945 - 1000 | 22 | 0945 - 1045 | 65  | 0945 - 1000 | 14  | 0945 - 1045 | 62  |
| 1000 - 1015 | 17 | 1000 - 1100 | 118 | 1000 - 1015 | 18  | 1000 - 1100 | 174 |
| 1015 - 1030 | 15 | 1015 - 1115 | 191 | 1015 - 1030 | 10  | 1015 - 1115 | 340 |
| 1030 - 1045 | 11 | 1030 - 1130 | 190 | 1030 - 1045 | 20  | 1030 - 1130 | 352 |
| 1045 - 1100 | 75 | 1045 - 1145 | 200 | 1045 - 1100 | 126 | 1045 - 1145 | 359 |
| 1100 - 1115 | 90 | 1100 - 1200 | 135 | 1100 - 1115 | 184 | 1100 - 1200 | 253 |
| 1115 - 1130 | 14 | 1115 - 1215 | 62  | 1115 - 1130 | 22  | 1115 - 1215 | 96  |
| 1130 - 1145 | 21 | 1130 - 1230 | 85  | 1130 - 1145 | 27  | 1130 - 1230 | 89  |
| 1145 - 1200 | 10 | 1145 - 1245 | 86  | 1145 - 1200 | 20  | 1145 - 1245 | 109 |
| 1200 - 1215 | 17 | 1200 - 1300 | 150 | 1200 - 1215 | 27  | 1200 - 1300 | 152 |
| 1215 - 1230 | 37 | 1215 - 1315 | 203 | 1215 - 1230 | 15  | 1215 - 1315 | 195 |
| 1230 - 1245 | 22 | 1230 - 1330 | 189 | 1230 - 1245 | 47  | 1230 - 1330 | 212 |
| 1245 - 1300 | 74 | 1245 - 1345 | 180 | 1245 - 1300 | 63  | 1245 - 1345 | 207 |
| 1300 - 1315 | 70 | 1300 - 1400 | 128 | 1300 - 1315 | 70  | 1300 - 1400 | 279 |
| 1315 - 1330 | 23 | 1315 - 1415 | 91  | 1315 - 1330 | 32  | 1315 - 1415 | 272 |
| 1330 - 1345 | 13 | 1330 - 1430 | 85  | 1330 - 1345 | 42  | 1330 - 1430 | 267 |
| 1345 - 1400 | 22 | 1345 - 1445 | 86  | 1345 - 1400 | 135 | 1345 - 1445 | 251 |
| 1400 - 1415 | 33 | 1400 - 1500 | 73  | 1400 - 1415 | 63  | 1400 - 1500 | 143 |
| 1415 - 1430 | 17 | 1415 - 1515 | 70  | 1415 - 1430 | 27  | 1415 - 1515 | 105 |
| 1430 - 1445 | 14 | 1430 - 1530 | 69  | 1430 - 1445 | 26  | 1430 - 1530 | 96  |
| 1445 - 1500 | 9  | 1445 - 1545 | 71  | 1445 - 1500 | 27  | 1445 - 1545 | 97  |
| 1500 - 1515 | 30 | 1500 - 1600 | 107 | 1500 - 1515 | 25  | 1500 - 1600 | 119 |
| 1515 - 1530 | 16 | 1515 - 1615 | 128 | 1515 - 1530 | 18  | 1515 - 1615 | 122 |
| 1530 - 1545 | 16 | 1530 - 1630 | 119 | 1530 - 1545 | 27  | 1530 - 1630 | 120 |
| 1545 - 1600 | 45 | 1545 - 1645 | 113 | 1545 - 1600 | 49  | 1545 - 1645 | 115 |
| 1600 - 1615 | 51 | 1600 - 1700 | 81  | 1600 - 1615 | 28  | 1600 - 1700 | 94  |
| 1615 - 1630 | 7  | 1615 - 1715 | 44  | 1615 - 1630 | 16  | 1615 - 1715 | 97  |
| 1630 - 1645 | 10 | 1630 - 1730 | 48  | 1630 - 1645 | 22  | 1630 - 1730 | 104 |
| 1645 - 1700 | 13 | 1645 - 1745 | 43  | 1645 - 1700 | 28  | 1645 - 1745 | 117 |
| 1700 - 1715 | 14 | 1700 - 1800 | 46  | 1700 - 1715 | 31  | 1700 - 1800 | 121 |
| 1715 - 1730 | 11 | 1715 - 1815 | 64  | 1715 - 1730 | 23  | 1715 - 1815 | 110 |
| 1730 - 1745 | 5  | 1730 - 1830 | 62  | 1730 - 1745 | 35  | 1730 - 1830 | 98  |
| 1745 - 1800 | 16 | 1745 - 1845 | 61  | 1745 - 1800 | 32  | 1745 - 1845 | 77  |
| 1800 - 1815 | 32 | 1800 - 1900 | 52  | 1800 - 1815 | 20  | 1800 - 1900 | 57  |
| 1815 - 1830 | 9  |             |     | 1815 - 1830 | 11  |             |     |
| 1830 - 1845 | 4  |             |     | 1830 - 1845 | 14  |             |     |
| 1845 - 1900 | 7  |             |     | 1845 - 1900 | 12  |             |     |

**TSUK**

Gordon St, London  
 Tuesday 08 October 2013  
**15 Minute and Hourly**

**Zone D**

| Zone D      |     |             |     |             |     |             |     |
|-------------|-----|-------------|-----|-------------|-----|-------------|-----|
| Eastbound   |     |             |     | Westbound   |     |             |     |
| 15 minute   |     | Hourly      |     | 15 minute   |     | Hourly      |     |
| 0700 - 0715 | 0   | 0700 - 0800 | 6   | 0700 - 0715 | 1   | 0700 - 0800 | 11  |
| 0715 - 0730 | 1   | 0715 - 0815 | 11  | 0715 - 0730 | 2   | 0715 - 0815 | 13  |
| 0730 - 0745 | 2   | 0730 - 0830 | 13  | 0730 - 0745 | 4   | 0730 - 0830 | 12  |
| 0745 - 0800 | 3   | 0745 - 0845 | 14  | 0745 - 0800 | 4   | 0745 - 0845 | 13  |
| 0800 - 0815 | 5   | 0800 - 0900 | 24  | 0800 - 0815 | 3   | 0800 - 0900 | 23  |
| 0815 - 0830 | 3   | 0815 - 0915 | 31  | 0815 - 0830 | 1   | 0815 - 0915 | 27  |
| 0830 - 0845 | 3   | 0830 - 0930 | 38  | 0830 - 0845 | 5   | 0830 - 0930 | 35  |
| 0845 - 0900 | 13  | 0845 - 0945 | 44  | 0845 - 0900 | 14  | 0845 - 0945 | 40  |
| 0900 - 0915 | 12  | 0900 - 1000 | 43  | 0900 - 0915 | 7   | 0900 - 1000 | 35  |
| 0915 - 0930 | 10  | 0915 - 1015 | 40  | 0915 - 0930 | 9   | 0915 - 1015 | 43  |
| 0930 - 0945 | 9   | 0930 - 1030 | 36  | 0930 - 0945 | 10  | 0930 - 1030 | 41  |
| 0945 - 1000 | 12  | 0945 - 1045 | 38  | 0945 - 1000 | 9   | 0945 - 1045 | 42  |
| 1000 - 1015 | 9   | 1000 - 1100 | 144 | 1000 - 1015 | 15  | 1000 - 1100 | 97  |
| 1015 - 1030 | 6   | 1015 - 1115 | 210 | 1015 - 1030 | 7   | 1015 - 1115 | 184 |
| 1030 - 1045 | 11  | 1030 - 1130 | 209 | 1030 - 1045 | 11  | 1030 - 1130 | 187 |
| 1045 - 1100 | 118 | 1045 - 1145 | 211 | 1045 - 1100 | 64  | 1045 - 1145 | 188 |
| 1100 - 1115 | 75  | 1100 - 1200 | 109 | 1100 - 1115 | 102 | 1100 - 1200 | 132 |
| 1115 - 1130 | 5   | 1115 - 1215 | 44  | 1115 - 1130 | 10  | 1115 - 1215 | 44  |
| 1130 - 1145 | 13  | 1130 - 1230 | 82  | 1130 - 1145 | 12  | 1130 - 1230 | 46  |
| 1145 - 1200 | 16  | 1145 - 1245 | 98  | 1145 - 1200 | 8   | 1145 - 1245 | 58  |
| 1200 - 1215 | 10  | 1200 - 1300 | 216 | 1200 - 1215 | 14  | 1200 - 1300 | 101 |
| 1215 - 1230 | 43  | 1215 - 1315 | 230 | 1215 - 1230 | 12  | 1215 - 1315 | 131 |
| 1230 - 1245 | 29  | 1230 - 1330 | 215 | 1230 - 1245 | 24  | 1230 - 1330 | 147 |
| 1245 - 1300 | 134 | 1245 - 1345 | 206 | 1245 - 1300 | 51  | 1245 - 1345 | 144 |
| 1300 - 1315 | 24  | 1300 - 1400 | 105 | 1300 - 1315 | 44  | 1300 - 1400 | 177 |
| 1315 - 1330 | 28  | 1315 - 1415 | 121 | 1315 - 1330 | 28  | 1315 - 1415 | 184 |
| 1330 - 1345 | 20  | 1330 - 1430 | 117 | 1330 - 1345 | 21  | 1330 - 1430 | 170 |
| 1345 - 1400 | 33  | 1345 - 1445 | 105 | 1345 - 1400 | 84  | 1345 - 1445 | 165 |
| 1400 - 1415 | 40  | 1400 - 1500 | 78  | 1400 - 1415 | 51  | 1400 - 1500 | 96  |
| 1415 - 1430 | 24  | 1415 - 1515 | 65  | 1415 - 1430 | 14  | 1415 - 1515 | 72  |
| 1430 - 1445 | 8   | 1430 - 1530 | 61  | 1430 - 1445 | 16  | 1430 - 1530 | 80  |
| 1445 - 1500 | 6   | 1445 - 1545 | 66  | 1445 - 1500 | 15  | 1445 - 1545 | 79  |
| 1500 - 1515 | 27  | 1500 - 1600 | 89  | 1500 - 1515 | 27  | 1500 - 1600 | 103 |
| 1515 - 1530 | 20  | 1515 - 1615 | 124 | 1515 - 1530 | 22  | 1515 - 1615 | 106 |
| 1530 - 1545 | 13  | 1530 - 1630 | 110 | 1530 - 1545 | 15  | 1530 - 1630 | 92  |
| 1545 - 1600 | 29  | 1545 - 1645 | 106 | 1545 - 1600 | 39  | 1545 - 1645 | 86  |
| 1600 - 1615 | 62  | 1600 - 1700 | 97  | 1600 - 1615 | 30  | 1600 - 1700 | 70  |
| 1615 - 1630 | 6   | 1615 - 1715 | 55  | 1615 - 1630 | 8   | 1615 - 1715 | 63  |
| 1630 - 1645 | 9   | 1630 - 1730 | 67  | 1630 - 1645 | 9   | 1630 - 1730 | 83  |
| 1645 - 1700 | 20  | 1645 - 1745 | 68  | 1645 - 1700 | 23  | 1645 - 1745 | 94  |
| 1700 - 1715 | 20  | 1700 - 1800 | 80  | 1700 - 1715 | 23  | 1700 - 1800 | 96  |
| 1715 - 1730 | 18  | 1715 - 1815 | 94  | 1715 - 1730 | 28  | 1715 - 1815 | 96  |
| 1730 - 1745 | 10  | 1730 - 1830 | 89  | 1730 - 1745 | 20  | 1730 - 1830 | 76  |
| 1745 - 1800 | 32  | 1745 - 1845 | 84  | 1745 - 1800 | 25  | 1745 - 1845 | 70  |
| 1800 - 1815 | 34  | 1800 - 1900 | 60  | 1800 - 1815 | 23  | 1800 - 1900 | 50  |
| 1815 - 1830 | 13  |             |     | 1815 - 1830 | 8   |             |     |
| 1830 - 1845 | 5   |             |     | 1830 - 1845 | 14  |             |     |
| 1845 - 1900 | 8   |             |     | 1845 - 1900 | 5   |             |     |



**TSUK**

Gordon St, London

Tuesday 08 October 2013

**3 Hour Flows****Zonal Count**

| Time        | Zone A    |           | Zebra Crossing |           | Zone B    |           | Zone C    |           | Zone D    |           |
|-------------|-----------|-----------|----------------|-----------|-----------|-----------|-----------|-----------|-----------|-----------|
|             | Eastbound | Westbound | Eastbound      | Westbound | Eastbound | Westbound | Eastbound | Westbound | Eastbound | Westbound |
| 0700 - 1000 | 36        | 3         | 672            | 337       | 50        | 46        | 120       | 92        | 73        | 69        |
| 0800 - 1100 | 35        | 2         | 1048           | 706       | 88        | 110       | 229       | 253       | 211       | 155       |
| 0900 - 1200 | 27        | 5         | 1217           | 840       | 119       | 188       | 323       | 471       | 296       | 264       |
| 1000 - 1300 | 29        | 6         | 1402           | 1178      | 122       | 221       | 403       | 579       | 469       | 330       |
| 1100 - 1400 | 42        | 6         | 1833           | 1478      | 137       | 211       | 413       | 684       | 430       | 410       |
| 1200 - 1500 | 50        | 8         | 1811           | 1623      | 127       | 181       | 351       | 574       | 399       | 374       |
| 1300 - 1600 | 46        | 10        | 1763           | 1610      | 128       | 170       | 308       | 541       | 272       | 376       |
| 1400 - 1700 | 35        | 11        | 1442           | 1362      | 106       | 145       | 261       | 356       | 264       | 269       |
| 1500 - 1800 | 32        | 17        | 1544           | 1425      | 105       | 125       | 234       | 334       | 266       | 269       |
| 1600 - 1900 | 21        | 15        | 1482           | 1294      | 95        | 108       | 179       | 272       | 237       | 216       |

**TSUK**

Gordon St, London  
 Tuesday 08 October 2013  
**15 Minute and Hourly**

**College Entrance - In**

| In                               |     |             |     |                                   |    |             |     |
|----------------------------------|-----|-------------|-----|-----------------------------------|----|-------------|-----|
| CE1 - Left into College Entrance |     |             |     | CE2 - Right into College Entrance |    |             |     |
| 15 minute                        |     | Hourly      |     | 15 minute                         |    | Hourly      |     |
| 0700 - 0715                      | 1   | 0700 - 0800 | 5   | 0700 - 0715                       | 0  | 0700 - 0800 | 4   |
| 0715 - 0730                      | 0   | 0715 - 0815 | 9   | 0715 - 0730                       | 0  | 0715 - 0815 | 6   |
| 0730 - 0745                      | 1   | 0730 - 0830 | 14  | 0730 - 0745                       | 2  | 0730 - 0830 | 14  |
| 0745 - 0800                      | 3   | 0745 - 0845 | 28  | 0745 - 0800                       | 2  | 0745 - 0845 | 24  |
| 0800 - 0815                      | 5   | 0800 - 0900 | 49  | 0800 - 0815                       | 2  | 0800 - 0900 | 32  |
| 0815 - 0830                      | 5   | 0815 - 0915 | 65  | 0815 - 0830                       | 8  | 0815 - 0915 | 38  |
| 0830 - 0845                      | 15  | 0830 - 0930 | 66  | 0830 - 0845                       | 12 | 0830 - 0930 | 39  |
| 0845 - 0900                      | 24  | 0845 - 0945 | 65  | 0845 - 0900                       | 10 | 0845 - 0945 | 28  |
| 0900 - 0915                      | 21  | 0900 - 1000 | 58  | 0900 - 0915                       | 8  | 0900 - 1000 | 23  |
| 0915 - 0930                      | 6   | 0915 - 1015 | 54  | 0915 - 0930                       | 9  | 0915 - 1015 | 23  |
| 0930 - 0945                      | 14  | 0930 - 1030 | 63  | 0930 - 0945                       | 1  | 0930 - 1030 | 19  |
| 0945 - 1000                      | 17  | 0945 - 1045 | 58  | 0945 - 1000                       | 5  | 0945 - 1045 | 23  |
| 1000 - 1015                      | 17  | 1000 - 1100 | 97  | 1000 - 1015                       | 8  | 1000 - 1100 | 37  |
| 1015 - 1030                      | 15  | 1015 - 1115 | 198 | 1015 - 1030                       | 5  | 1015 - 1115 | 45  |
| 1030 - 1045                      | 9   | 1030 - 1130 | 189 | 1030 - 1045                       | 5  | 1030 - 1130 | 46  |
| 1045 - 1100                      | 56  | 1045 - 1145 | 186 | 1045 - 1100                       | 19 | 1045 - 1145 | 47  |
| 1100 - 1115                      | 118 | 1100 - 1200 | 145 | 1100 - 1115                       | 16 | 1100 - 1200 | 43  |
| 1115 - 1130                      | 6   | 1115 - 1215 | 40  | 1115 - 1130                       | 6  | 1115 - 1215 | 37  |
| 1130 - 1145                      | 6   | 1130 - 1230 | 58  | 1130 - 1145                       | 6  | 1130 - 1230 | 54  |
| 1145 - 1200                      | 15  | 1145 - 1245 | 61  | 1145 - 1200                       | 15 | 1145 - 1245 | 64  |
| 1200 - 1215                      | 13  | 1200 - 1300 | 100 | 1200 - 1215                       | 10 | 1200 - 1300 | 84  |
| 1215 - 1230                      | 24  | 1215 - 1315 | 155 | 1215 - 1230                       | 23 | 1215 - 1315 | 117 |
| 1230 - 1245                      | 9   | 1230 - 1330 | 152 | 1230 - 1245                       | 16 | 1230 - 1330 | 103 |
| 1245 - 1300                      | 54  | 1245 - 1345 | 162 | 1245 - 1300                       | 35 | 1245 - 1345 | 104 |
| 1300 - 1315                      | 68  | 1300 - 1400 | 148 | 1300 - 1315                       | 43 | 1300 - 1400 | 101 |
| 1315 - 1330                      | 21  | 1315 - 1415 | 103 | 1315 - 1330                       | 9  | 1315 - 1415 | 68  |
| 1330 - 1345                      | 19  | 1330 - 1430 | 99  | 1330 - 1345                       | 17 | 1330 - 1430 | 71  |
| 1345 - 1400                      | 40  | 1345 - 1445 | 100 | 1345 - 1400                       | 32 | 1345 - 1445 | 59  |
| 1400 - 1415                      | 23  | 1400 - 1500 | 78  | 1400 - 1415                       | 10 | 1400 - 1500 | 34  |
| 1415 - 1430                      | 17  | 1415 - 1515 | 71  | 1415 - 1430                       | 12 | 1415 - 1515 | 33  |
| 1430 - 1445                      | 20  | 1430 - 1530 | 68  | 1430 - 1445                       | 5  | 1430 - 1530 | 28  |
| 1445 - 1500                      | 18  | 1445 - 1545 | 60  | 1445 - 1500                       | 7  | 1445 - 1545 | 33  |
| 1500 - 1515                      | 16  | 1500 - 1600 | 59  | 1500 - 1515                       | 9  | 1500 - 1600 | 59  |
| 1515 - 1530                      | 14  | 1515 - 1615 | 106 | 1515 - 1530                       | 7  | 1515 - 1615 | 61  |
| 1530 - 1545                      | 12  | 1530 - 1630 | 107 | 1530 - 1545                       | 10 | 1530 - 1630 | 59  |
| 1545 - 1600                      | 17  | 1545 - 1645 | 103 | 1545 - 1600                       | 33 | 1545 - 1645 | 58  |
| 1600 - 1615                      | 63  | 1600 - 1700 | 101 | 1600 - 1615                       | 11 | 1600 - 1700 | 39  |
| 1615 - 1630                      | 15  | 1615 - 1715 | 64  | 1615 - 1630                       | 5  | 1615 - 1715 | 38  |
| 1630 - 1645                      | 8   | 1630 - 1730 | 68  | 1630 - 1645                       | 9  | 1630 - 1730 | 41  |
| 1645 - 1700                      | 15  | 1645 - 1745 | 68  | 1645 - 1700                       | 14 | 1645 - 1745 | 39  |
| 1700 - 1715                      | 26  | 1700 - 1800 | 78  | 1700 - 1715                       | 10 | 1700 - 1800 | 33  |
| 1715 - 1730                      | 19  | 1715 - 1815 | 67  | 1715 - 1730                       | 8  | 1715 - 1815 | 37  |
| 1730 - 1745                      | 8   | 1730 - 1830 | 54  | 1730 - 1745                       | 7  | 1730 - 1830 | 53  |
| 1745 - 1800                      | 25  | 1745 - 1845 | 52  | 1745 - 1800                       | 8  | 1745 - 1845 | 52  |
| 1800 - 1815                      | 15  | 1800 - 1900 | 32  | 1800 - 1815                       | 14 | 1800 - 1900 | 46  |
| 1815 - 1830                      | 6   |             |     | 1815 - 1830                       | 24 |             |     |
| 1830 - 1845                      | 6   |             |     | 1830 - 1845                       | 6  |             |     |
| 1845 - 1900                      | 5   |             |     | 1845 - 1900                       | 2  |             |     |

**TSUK**

Gordon St, London  
 Tuesday 08 October 2013  
**15 Minute and Hourly**

**College Entrance - Out**

| Out                                |     |             |     |                                     |    |             |     |
|------------------------------------|-----|-------------|-----|-------------------------------------|----|-------------|-----|
| CE3 - Left Out to Gordon St, North |     |             |     | CE4 - Right Out to Gordon St, South |    |             |     |
| 15 minute                          |     | Hourly      |     | 15 minute                           |    | Hourly      |     |
| 0700 - 0715                        | 1   | 0700 - 0800 | 5   | 0700 - 0715                         | 0  | 0700 - 0800 | 1   |
| 0715 - 0730                        | 0   | 0715 - 0815 | 5   | 0715 - 0730                         | 0  | 0715 - 0815 | 1   |
| 0730 - 0745                        | 1   | 0730 - 0830 | 6   | 0730 - 0745                         | 1  | 0730 - 0830 | 1   |
| 0745 - 0800                        | 3   | 0745 - 0845 | 7   | 0745 - 0800                         | 0  | 0745 - 0845 | 2   |
| 0800 - 0815                        | 1   | 0800 - 0900 | 6   | 0800 - 0815                         | 0  | 0800 - 0900 | 11  |
| 0815 - 0830                        | 1   | 0815 - 0915 | 6   | 0815 - 0830                         | 0  | 0815 - 0915 | 12  |
| 0830 - 0845                        | 2   | 0830 - 0930 | 6   | 0830 - 0845                         | 2  | 0830 - 0930 | 13  |
| 0845 - 0900                        | 2   | 0845 - 0945 | 6   | 0845 - 0900                         | 9  | 0845 - 0945 | 11  |
| 0900 - 0915                        | 1   | 0900 - 1000 | 20  | 0900 - 0915                         | 1  | 0900 - 1000 | 11  |
| 0915 - 0930                        | 1   | 0915 - 1015 | 27  | 0915 - 0930                         | 1  | 0915 - 1015 | 19  |
| 0930 - 0945                        | 2   | 0930 - 1030 | 31  | 0930 - 0945                         | 0  | 0930 - 1030 | 20  |
| 0945 - 1000                        | 16  | 0945 - 1045 | 34  | 0945 - 1000                         | 9  | 0945 - 1045 | 23  |
| 1000 - 1015                        | 8   | 1000 - 1100 | 47  | 1000 - 1015                         | 9  | 1000 - 1100 | 26  |
| 1015 - 1030                        | 5   | 1015 - 1115 | 149 | 1015 - 1030                         | 2  | 1015 - 1115 | 42  |
| 1030 - 1045                        | 5   | 1030 - 1130 | 159 | 1030 - 1045                         | 3  | 1030 - 1130 | 46  |
| 1045 - 1100                        | 29  | 1045 - 1145 | 173 | 1045 - 1100                         | 12 | 1045 - 1145 | 50  |
| 1100 - 1115                        | 110 | 1100 - 1200 | 149 | 1100 - 1115                         | 25 | 1100 - 1200 | 47  |
| 1115 - 1130                        | 15  | 1115 - 1215 | 58  | 1115 - 1130                         | 6  | 1115 - 1215 | 34  |
| 1130 - 1145                        | 19  | 1130 - 1230 | 55  | 1130 - 1145                         | 7  | 1130 - 1230 | 40  |
| 1145 - 1200                        | 5   | 1145 - 1245 | 54  | 1145 - 1200                         | 9  | 1145 - 1245 | 54  |
| 1200 - 1215                        | 19  | 1200 - 1300 | 99  | 1200 - 1215                         | 12 | 1200 - 1300 | 80  |
| 1215 - 1230                        | 12  | 1215 - 1315 | 139 | 1215 - 1230                         | 12 | 1215 - 1315 | 106 |
| 1230 - 1245                        | 18  | 1230 - 1330 | 163 | 1230 - 1245                         | 21 | 1230 - 1330 | 120 |
| 1245 - 1300                        | 50  | 1245 - 1345 | 180 | 1245 - 1300                         | 35 | 1245 - 1345 | 132 |
| 1300 - 1315                        | 59  | 1300 - 1400 | 197 | 1300 - 1315                         | 38 | 1300 - 1400 | 138 |
| 1315 - 1330                        | 36  | 1315 - 1415 | 203 | 1315 - 1330                         | 26 | 1315 - 1415 | 125 |
| 1330 - 1345                        | 35  | 1330 - 1430 | 177 | 1330 - 1345                         | 33 | 1330 - 1430 | 115 |
| 1345 - 1400                        | 67  | 1345 - 1445 | 155 | 1345 - 1400                         | 41 | 1345 - 1445 | 92  |
| 1400 - 1415                        | 65  | 1400 - 1500 | 108 | 1400 - 1415                         | 25 | 1400 - 1500 | 68  |
| 1415 - 1430                        | 10  | 1415 - 1515 | 56  | 1415 - 1430                         | 16 | 1415 - 1515 | 54  |
| 1430 - 1445                        | 13  | 1430 - 1530 | 61  | 1430 - 1445                         | 10 | 1430 - 1530 | 45  |
| 1445 - 1500                        | 20  | 1445 - 1545 | 68  | 1445 - 1500                         | 17 | 1445 - 1545 | 52  |
| 1500 - 1515                        | 13  | 1500 - 1600 | 90  | 1500 - 1515                         | 11 | 1500 - 1600 | 53  |
| 1515 - 1530                        | 15  | 1515 - 1615 | 99  | 1515 - 1530                         | 7  | 1515 - 1615 | 51  |
| 1530 - 1545                        | 20  | 1530 - 1630 | 102 | 1530 - 1545                         | 17 | 1530 - 1630 | 56  |
| 1545 - 1600                        | 42  | 1545 - 1645 | 100 | 1545 - 1600                         | 18 | 1545 - 1645 | 50  |
| 1600 - 1615                        | 22  | 1600 - 1700 | 80  | 1600 - 1615                         | 9  | 1600 - 1700 | 58  |
| 1615 - 1630                        | 18  | 1615 - 1715 | 85  | 1615 - 1630                         | 12 | 1615 - 1715 | 65  |
| 1630 - 1645                        | 18  | 1630 - 1730 | 79  | 1630 - 1645                         | 11 | 1630 - 1730 | 61  |
| 1645 - 1700                        | 22  | 1645 - 1745 | 80  | 1645 - 1700                         | 26 | 1645 - 1745 | 65  |
| 1700 - 1715                        | 27  | 1700 - 1800 | 79  | 1700 - 1715                         | 16 | 1700 - 1800 | 47  |
| 1715 - 1730                        | 12  | 1715 - 1815 | 69  | 1715 - 1730                         | 8  | 1715 - 1815 | 43  |
| 1730 - 1745                        | 19  | 1730 - 1830 | 65  | 1730 - 1745                         | 15 | 1730 - 1830 | 45  |
| 1745 - 1800                        | 21  | 1745 - 1845 | 62  | 1745 - 1800                         | 8  | 1745 - 1845 | 38  |
| 1800 - 1815                        | 17  | 1800 - 1900 | 51  | 1800 - 1815                         | 12 | 1800 - 1900 | 33  |
| 1815 - 1830                        | 8   |             |     | 1815 - 1830                         | 10 |             |     |
| 1830 - 1845                        | 16  |             |     | 1830 - 1845                         | 8  |             |     |
| 1845 - 1900                        | 10  |             |     | 1845 - 1900                         | 3  |             |     |

TSUK

Gordon St, London

Tuesday 08 October 2013

15 Minute and Hourly

College Entrance - Passing Flow

| Passing Flow |     |             |      |             |     |             |      |
|--------------|-----|-------------|------|-------------|-----|-------------|------|
| Northbound   |     |             |      | Southbound  |     |             |      |
| 15 minute    |     | Hourly      |      | 15 minute   |     | Hourly      |      |
| 0700 - 0715  | 17  | 0700 - 0800 | 86   | 0700 - 0715 | 16  | 0700 - 0800 | 166  |
| 0715 - 0730  | 8   | 0715 - 0815 | 97   | 0715 - 0730 | 34  | 0715 - 0815 | 231  |
| 0730 - 0745  | 27  | 0730 - 0830 | 142  | 0730 - 0745 | 43  | 0730 - 0830 | 310  |
| 0745 - 0800  | 34  | 0745 - 0845 | 202  | 0745 - 0800 | 73  | 0745 - 0845 | 446  |
| 0800 - 0815  | 28  | 0800 - 0900 | 357  | 0800 - 0815 | 81  | 0800 - 0900 | 933  |
| 0815 - 0830  | 53  | 0815 - 0915 | 453  | 0815 - 0830 | 113 | 0815 - 0915 | 1194 |
| 0830 - 0845  | 87  | 0830 - 0930 | 465  | 0830 - 0845 | 179 | 0830 - 0930 | 1314 |
| 0845 - 0900  | 189 | 0845 - 0945 | 448  | 0845 - 0900 | 560 | 0845 - 0945 | 1365 |
| 0900 - 0915  | 124 | 0900 - 1000 | 395  | 0900 - 0915 | 342 | 0900 - 1000 | 1132 |
| 0915 - 0930  | 65  | 0915 - 1015 | 398  | 0915 - 0930 | 233 | 0915 - 1015 | 1095 |
| 0930 - 0945  | 70  | 0930 - 1030 | 483  | 0930 - 0945 | 230 | 0930 - 1030 | 1037 |
| 0945 - 1000  | 136 | 0945 - 1045 | 520  | 0945 - 1000 | 327 | 0945 - 1045 | 1007 |
| 1000 - 1015  | 127 | 1000 - 1100 | 684  | 1000 - 1015 | 305 | 1000 - 1100 | 1120 |
| 1015 - 1030  | 150 | 1015 - 1115 | 842  | 1015 - 1030 | 175 | 1015 - 1115 | 1200 |
| 1030 - 1045  | 107 | 1030 - 1130 | 792  | 1030 - 1045 | 200 | 1030 - 1130 | 1155 |
| 1045 - 1100  | 300 | 1045 - 1145 | 785  | 1045 - 1100 | 440 | 1045 - 1145 | 1087 |
| 1100 - 1115  | 285 | 1100 - 1200 | 650  | 1100 - 1115 | 385 | 1100 - 1200 | 792  |
| 1115 - 1130  | 100 | 1115 - 1215 | 565  | 1115 - 1130 | 130 | 1115 - 1215 | 647  |
| 1130 - 1145  | 100 | 1130 - 1230 | 595  | 1130 - 1145 | 132 | 1130 - 1230 | 827  |
| 1145 - 1200  | 165 | 1145 - 1245 | 725  | 1145 - 1200 | 145 | 1145 - 1245 | 920  |
| 1200 - 1215  | 200 | 1200 - 1300 | 1000 | 1200 - 1215 | 240 | 1200 - 1300 | 1455 |
| 1215 - 1230  | 130 | 1215 - 1315 | 1360 | 1215 - 1230 | 310 | 1215 - 1315 | 1825 |
| 1230 - 1245  | 230 | 1230 - 1330 | 1472 | 1230 - 1245 | 225 | 1230 - 1330 | 1760 |
| 1245 - 1300  | 440 | 1245 - 1345 | 1542 | 1245 - 1300 | 680 | 1245 - 1345 | 1782 |
| 1300 - 1315  | 560 | 1300 - 1400 | 1527 | 1300 - 1315 | 610 | 1300 - 1400 | 1505 |
| 1315 - 1330  | 242 | 1315 - 1415 | 1347 | 1315 - 1330 | 245 | 1315 - 1415 | 1180 |
| 1330 - 1345  | 300 | 1330 - 1430 | 1246 | 1330 - 1345 | 247 | 1330 - 1430 | 1110 |
| 1345 - 1400  | 425 | 1345 - 1445 | 1070 | 1345 - 1400 | 403 | 1345 - 1445 | 1003 |
| 1400 - 1415  | 380 | 1400 - 1500 | 835  | 1400 - 1415 | 285 | 1400 - 1500 | 745  |
| 1415 - 1430  | 141 | 1415 - 1515 | 685  | 1415 - 1430 | 175 | 1415 - 1515 | 620  |
| 1430 - 1445  | 124 | 1430 - 1530 | 714  | 1430 - 1445 | 140 | 1430 - 1530 | 560  |
| 1445 - 1500  | 190 | 1445 - 1545 | 694  | 1445 - 1500 | 145 | 1445 - 1545 | 640  |
| 1500 - 1515  | 230 | 1500 - 1600 | 810  | 1500 - 1515 | 160 | 1500 - 1600 | 730  |
| 1515 - 1530  | 170 | 1515 - 1615 | 915  | 1515 - 1530 | 115 | 1515 - 1615 | 820  |
| 1530 - 1545  | 104 | 1530 - 1630 | 902  | 1530 - 1545 | 220 | 1530 - 1630 | 838  |
| 1545 - 1600  | 306 | 1545 - 1645 | 956  | 1545 - 1600 | 235 | 1545 - 1645 | 723  |
| 1600 - 1615  | 335 | 1600 - 1700 | 926  | 1600 - 1615 | 250 | 1600 - 1700 | 658  |
| 1615 - 1630  | 157 | 1615 - 1715 | 909  | 1615 - 1630 | 133 | 1615 - 1715 | 608  |
| 1630 - 1645  | 158 | 1630 - 1730 | 959  | 1630 - 1645 | 105 | 1630 - 1730 | 605  |
| 1645 - 1700  | 276 | 1645 - 1745 | 1000 | 1645 - 1700 | 170 | 1645 - 1745 | 640  |
| 1700 - 1715  | 318 | 1700 - 1800 | 1022 | 1700 - 1715 | 200 | 1700 - 1800 | 670  |
| 1715 - 1730  | 207 | 1715 - 1815 | 1001 | 1715 - 1730 | 130 | 1715 - 1815 | 625  |
| 1730 - 1745  | 199 | 1730 - 1830 | 969  | 1730 - 1745 | 140 | 1730 - 1830 | 595  |
| 1745 - 1800  | 298 | 1745 - 1845 | 963  | 1745 - 1800 | 200 | 1745 - 1845 | 553  |
| 1800 - 1815  | 297 | 1800 - 1900 | 891  | 1800 - 1815 | 155 | 1800 - 1900 | 450  |
| 1815 - 1830  | 175 |             |      | 1815 - 1830 | 100 |             |      |
| 1830 - 1845  | 193 |             |      | 1830 - 1845 | 98  |             |      |
| 1845 - 1900  | 226 |             |      | 1845 - 1900 | 97  |             |      |

**TSUK**

Gordon St, London

Tuesday 08 October 2013

**3 Hour Flows****College Entrance**

| Time        | In            |                | Out            |                 | Passing    |            |
|-------------|---------------|----------------|----------------|-----------------|------------|------------|
|             | CE1 - Left In | CE2 - Right In | CE3 - Left Out | CE4 - Right Out | Northbound | Southbound |
| 0700 - 1000 | 112           | 59             | 31             | 23              | 838        | 2231       |
| 0800 - 1100 | 204           | 92             | 73             | 48              | 1436       | 3185       |
| 0900 - 1200 | 300           | 103            | 216            | 84              | 1729       | 3044       |
| 1000 - 1300 | 342           | 164            | 295            | 153             | 2334       | 3367       |
| 1100 - 1400 | 393           | 228            | 445            | 265             | 3177       | 3752       |
| 1200 - 1500 | 326           | 219            | 404            | 286             | 3362       | 3705       |
| 1300 - 1600 | 285           | 194            | 395            | 259             | 3172       | 2980       |
| 1400 - 1700 | 238           | 132            | 278            | 179             | 2571       | 2133       |
| 1500 - 1800 | 238           | 131            | 249            | 158             | 2758       | 2058       |
| 1600 - 1900 | 211           | 118            | 210            | 138             | 2839       | 1778       |

## **A9. PROPOSED CROSSING LOCATION**

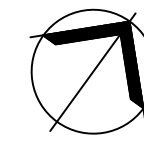
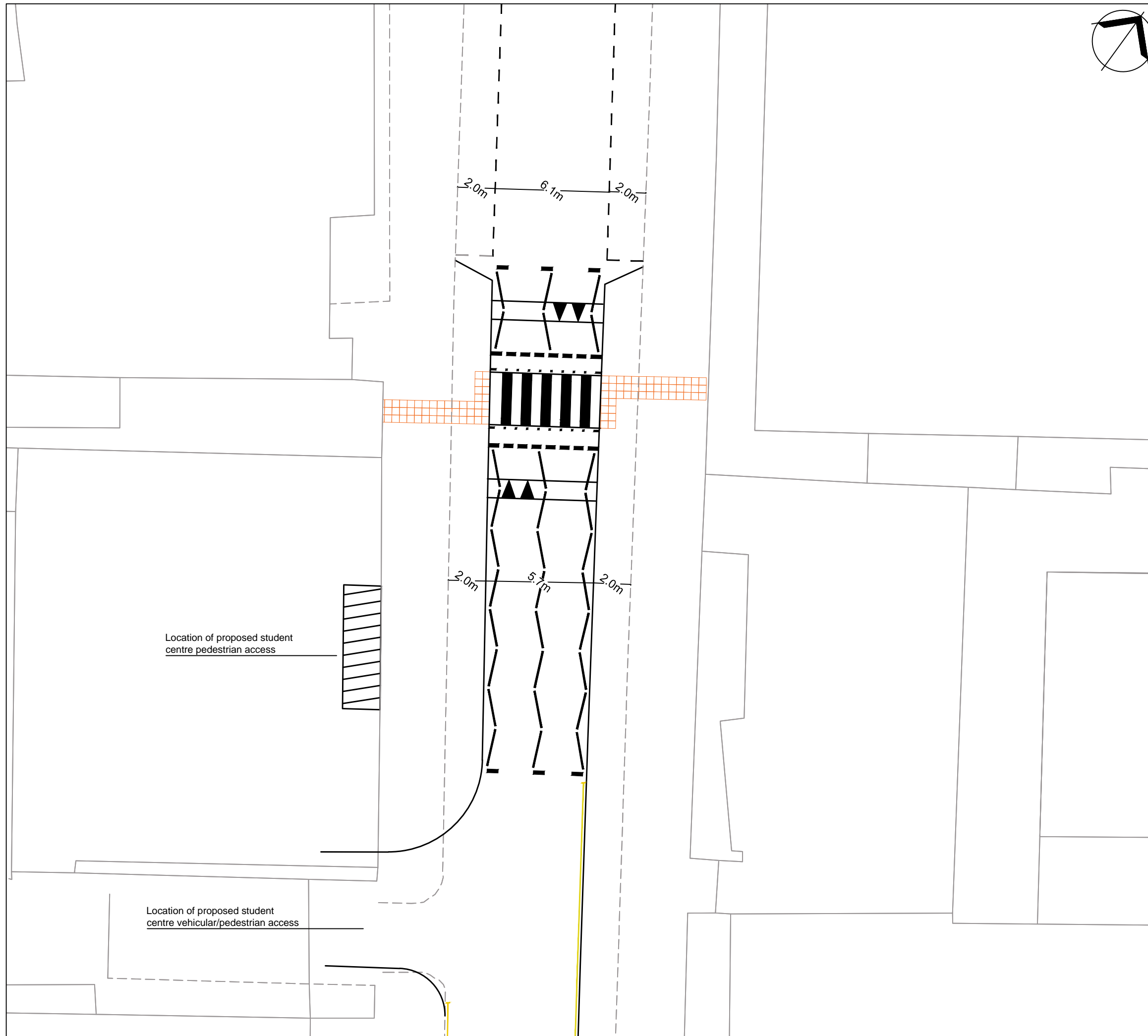

Notes;  
 1. Based upon the Ordnance Survey's (1:1250) Map with permission of the controller of Her Majesty's Stationery Office, Crown copyright reserved.  
 2. The crossings shown have been designed in accordance with 'The Zebra, Pelican and Puffin Pedestrian Crossings Regulations and General Directions 1997' document.

| Rev | Date     | Amendments     | Drawn | Chk | App |
|-----|----------|----------------|-------|-----|-----|
| B   | 18.05.15 | Access Amended | RB    | ME  | FP  |
| A   | 08.05.15 | Access Amended | RB    | FP  | FP  |

**Iceni Projects**  
 Flitcroft House  
 114-116 Charing Cross Road  
 London, WC2H 0JR



T 020 3640 8508  
 F 020 3435 4228  
 mail@iceniprojects.com



Client \_\_\_\_\_

University College London (UCL) Estates

Project \_\_\_\_\_

Student Centre, Gordon Street, London

Title \_\_\_\_\_

Proposed Zebra Crossing

|                |                                |                                 |
|----------------|--------------------------------|---------------------------------|
| Drawn By<br>RB | Checked By<br>FP<br>21.04.2015 | Approved By<br>FP<br>21.04.2015 |
|----------------|--------------------------------|---------------------------------|

|                     |                    |
|---------------------|--------------------|
| Scale @ A3<br>1:200 | Date<br>21.04.2015 |
|---------------------|--------------------|

|                        |                   |           |
|------------------------|-------------------|-----------|
| Project No.<br>13-T097 | Drawing No.<br>06 | Rev.<br>B |
|------------------------|-------------------|-----------|

## **A10. CLASSIFIED TURNING MOVEMENTS – EXISTING SITE ACCESS**



**TSUK**

Gordon St, London  
 Tuesday 08 October 2013  
**Service Entrance**

| Time        | SE1 - Left into Service Entrance |    |     |     |      |      |     |       | Hourly Totals |       |
|-------------|----------------------------------|----|-----|-----|------|------|-----|-------|---------------|-------|
|             | PC                               | MC | CAR | LGV | OGV1 | OGV2 | PSV | Total | Hourly        | Total |
| 0700 - 0715 | 0                                | 0  | 0   | 0   | 0    | 0    | 0   | 0     | 0700 - 0800   | 2     |
| 0715 - 0730 | 0                                | 0  | 0   | 0   | 0    | 0    | 0   | 0     | 0715 - 0815   | 2     |
| 0730 - 0745 | 0                                | 0  | 1   | 0   | 0    | 0    | 0   | 1     | 0730 - 0830   | 3     |
| 0745 - 0800 | 1                                | 0  | 0   | 0   | 0    | 0    | 0   | 1     | 0745 - 0845   | 3     |
| 0800 - 0815 | 0                                | 0  | 0   | 0   | 0    | 0    | 0   | 0     | 0800 - 0900   | 2     |
| 0815 - 0830 | 0                                | 0  | 1   | 0   | 0    | 0    | 0   | 1     | 0815 - 0915   | 2     |
| 0830 - 0845 | 1                                | 0  | 0   | 0   | 0    | 0    | 0   | 1     | 0830 - 0930   | 2     |
| 0845 - 0900 | 0                                | 0  | 0   | 0   | 0    | 0    | 0   | 0     | 0845 - 0945   | 1     |
| 0900 - 0915 | 0                                | 0  | 0   | 0   | 0    | 0    | 0   | 0     | 0900 - 1000   | 1     |
| 0915 - 0930 | 0                                | 0  | 0   | 1   | 0    | 0    | 0   | 1     | 0915 - 1015   | 1     |
| 0930 - 0945 | 0                                | 0  | 0   | 0   | 0    | 0    | 0   | 0     | 0930 - 1030   | 0     |
| 0945 - 1000 | 0                                | 0  | 0   | 0   | 0    | 0    | 0   | 0     | 0945 - 1045   | 2     |
| 1000 - 1015 | 0                                | 0  | 0   | 0   | 0    | 0    | 0   | 0     | 1000 - 1100   | 2     |
| 1015 - 1030 | 0                                | 0  | 0   | 0   | 0    | 0    | 0   | 0     | 1015 - 1115   | 2     |
| 1030 - 1045 | 0                                | 0  | 0   | 2   | 0    | 0    | 0   | 2     | 1030 - 1130   | 3     |
| 1045 - 1100 | 0                                | 0  | 0   | 0   | 0    | 0    | 0   | 0     | 1045 - 1145   | 3     |
| 1100 - 1115 | 0                                | 0  | 0   | 0   | 0    | 0    | 0   | 0     | 1100 - 1200   | 4     |
| 1115 - 1130 | 0                                | 0  | 0   | 1   | 0    | 0    | 0   | 1     | 1115 - 1215   | 4     |
| 1130 - 1145 | 2                                | 0  | 0   | 0   | 0    | 0    | 0   | 2     | 1130 - 1230   | 3     |
| 1145 - 1200 | 0                                | 0  | 0   | 1   | 0    | 0    | 0   | 1     | 1145 - 1245   | 1     |
| 1200 - 1215 | 0                                | 0  | 0   | 0   | 0    | 0    | 0   | 0     | 1200 - 1300   | 0     |
| 1215 - 1230 | 0                                | 0  | 0   | 0   | 0    | 0    | 0   | 0     | 1215 - 1315   | 0     |
| 1230 - 1245 | 0                                | 0  | 0   | 0   | 0    | 0    | 0   | 0     | 1230 - 1330   | 1     |
| 1245 - 1300 | 0                                | 0  | 0   | 0   | 0    | 0    | 0   | 0     | 1245 - 1345   | 1     |
| 1300 - 1315 | 0                                | 0  | 0   | 0   | 0    | 0    | 0   | 0     | 1300 - 1400   | 2     |
| 1315 - 1330 | 0                                | 0  | 0   | 1   | 0    | 0    | 0   | 1     | 1315 - 1415   | 4     |
| 1330 - 1345 | 0                                | 0  | 0   | 0   | 0    | 0    | 0   | 0     | 1330 - 1430   | 3     |
| 1345 - 1400 | 0                                | 0  | 0   | 1   | 0    | 0    | 0   | 1     | 1345 - 1445   | 3     |
| 1400 - 1415 | 0                                | 0  | 0   | 2   | 0    | 0    | 0   | 2     | 1400 - 1500   | 2     |
| 1415 - 1430 | 0                                | 0  | 0   | 0   | 0    | 0    | 0   | 0     | 1415 - 1515   | 0     |
| 1430 - 1445 | 0                                | 0  | 0   | 0   | 0    | 0    | 0   | 0     | 1430 - 1530   | 0     |
| 1445 - 1500 | 0                                | 0  | 0   | 0   | 0    | 0    | 0   | 0     | 1445 - 1545   | 0     |
| 1500 - 1515 | 0                                | 0  | 0   | 0   | 0    | 0    | 0   | 0     | 1500 - 1600   | 0     |
| 1515 - 1530 | 0                                | 0  | 0   | 0   | 0    | 0    | 0   | 0     | 1515 - 1615   | 0     |
| 1530 - 1545 | 0                                | 0  | 0   | 0   | 0    | 0    | 0   | 0     | 1530 - 1630   | 0     |
| 1545 - 1600 | 0                                | 0  | 0   | 0   | 0    | 0    | 0   | 0     | 1545 - 1645   | 0     |
| 1600 - 1615 | 0                                | 0  | 0   | 0   | 0    | 0    | 0   | 0     | 1600 - 1700   | 0     |
| 1615 - 1630 | 0                                | 0  | 0   | 0   | 0    | 0    | 0   | 0     | 1615 - 1715   | 0     |
| 1630 - 1645 | 0                                | 0  | 0   | 0   | 0    | 0    | 0   | 0     | 1630 - 1730   | 0     |
| 1645 - 1700 | 0                                | 0  | 0   | 0   | 0    | 0    | 0   | 0     | 1645 - 1745   | 0     |
| 1700 - 1715 | 0                                | 0  | 0   | 0   | 0    | 0    | 0   | 0     | 1700 - 1800   | 0     |
| 1715 - 1730 | 0                                | 0  | 0   | 0   | 0    | 0    | 0   | 0     | 1715 - 1815   | 1     |
| 1730 - 1745 | 0                                | 0  | 0   | 0   | 0    | 0    | 0   | 0     | 1730 - 1830   | 1     |
| 1745 - 1800 | 0                                | 0  | 0   | 0   | 0    | 0    | 0   | 0     | 1745 - 1845   | 1     |
| 1800 - 1815 | 0                                | 0  | 1   | 0   | 0    | 0    | 0   | 1     | 1800 - 1900   | 1     |
| 1815 - 1830 | 0                                | 0  | 0   | 0   | 0    | 0    | 0   | 0     |               |       |
| 1830 - 1845 | 0                                | 0  | 0   | 0   | 0    | 0    | 0   | 0     |               |       |
| 1845 - 1900 | 0                                | 0  | 0   | 0   | 0    | 0    | 0   | 0     |               |       |

**TSUK**

Gordon St, London  
 Tuesday 08 October 2013  
**Service Entrance**

| Time        | SE2 - Right into Service Entrance |    |     |     |      |      |     |       | Hourly Totals |       |
|-------------|-----------------------------------|----|-----|-----|------|------|-----|-------|---------------|-------|
|             | PC                                | MC | CAR | LGV | OGV1 | OGV2 | PSV | Total | Hourly        | Total |
| 0700 - 0715 | 0                                 | 0  | 0   | 3   | 0    | 0    | 0   | 3     | 0700 - 0800   | 10    |
| 0715 - 0730 | 0                                 | 0  | 0   | 0   | 2    | 0    | 0   | 2     | 0715 - 0815   | 7     |
| 0730 - 0745 | 2                                 | 0  | 0   | 0   | 0    | 0    | 0   | 2     | 0730 - 0830   | 8     |
| 0745 - 0800 | 1                                 | 0  | 0   | 1   | 1    | 0    | 0   | 3     | 0745 - 0845   | 6     |
| 0800 - 0815 | 0                                 | 0  | 0   | 0   | 0    | 0    | 0   | 0     | 0800 - 0900   | 5     |
| 0815 - 0830 | 1                                 | 0  | 0   | 2   | 0    | 0    | 0   | 3     | 0815 - 0915   | 6     |
| 0830 - 0845 | 0                                 | 0  | 0   | 0   | 0    | 0    | 0   | 0     | 0830 - 0930   | 4     |
| 0845 - 0900 | 0                                 | 0  | 0   | 2   | 0    | 0    | 0   | 2     | 0845 - 0945   | 6     |
| 0900 - 0915 | 0                                 | 0  | 0   | 1   | 0    | 0    | 0   | 1     | 0900 - 1000   | 5     |
| 0915 - 0930 | 0                                 | 0  | 0   | 1   | 0    | 0    | 0   | 1     | 0915 - 1015   | 4     |
| 0930 - 0945 | 0                                 | 0  | 0   | 2   | 0    | 0    | 0   | 2     | 0930 - 1030   | 3     |
| 0945 - 1000 | 0                                 | 0  | 0   | 1   | 0    | 0    | 0   | 1     | 0945 - 1045   | 1     |
| 1000 - 1015 | 0                                 | 0  | 0   | 0   | 0    | 0    | 0   | 0     | 1000 - 1100   | 0     |
| 1015 - 1030 | 0                                 | 0  | 0   | 0   | 0    | 0    | 0   | 0     | 1015 - 1115   | 0     |
| 1030 - 1045 | 0                                 | 0  | 0   | 0   | 0    | 0    | 0   | 0     | 1030 - 1130   | 0     |
| 1045 - 1100 | 0                                 | 0  | 0   | 0   | 0    | 0    | 0   | 0     | 1045 - 1145   | 2     |
| 1100 - 1115 | 0                                 | 0  | 0   | 0   | 0    | 0    | 0   | 0     | 1100 - 1200   | 3     |
| 1115 - 1130 | 0                                 | 0  | 0   | 0   | 0    | 0    | 0   | 0     | 1115 - 1215   | 3     |
| 1130 - 1145 | 0                                 | 0  | 1   | 1   | 0    | 0    | 0   | 2     | 1130 - 1230   | 4     |
| 1145 - 1200 | 0                                 | 0  | 0   | 1   | 0    | 0    | 0   | 1     | 1145 - 1245   | 2     |
| 1200 - 1215 | 0                                 | 0  | 0   | 0   | 0    | 0    | 0   | 0     | 1200 - 1300   | 4     |
| 1215 - 1230 | 0                                 | 0  | 0   | 1   | 0    | 0    | 0   | 1     | 1215 - 1315   | 5     |
| 1230 - 1245 | 0                                 | 0  | 0   | 0   | 0    | 0    | 0   | 0     | 1230 - 1330   | 4     |
| 1245 - 1300 | 0                                 | 0  | 0   | 3   | 0    | 0    | 0   | 3     | 1245 - 1345   | 4     |
| 1300 - 1315 | 0                                 | 0  | 0   | 1   | 0    | 0    | 0   | 1     | 1300 - 1400   | 1     |
| 1315 - 1330 | 0                                 | 0  | 0   | 0   | 0    | 0    | 0   | 0     | 1315 - 1415   | 2     |
| 1330 - 1345 | 0                                 | 0  | 0   | 0   | 0    | 0    | 0   | 0     | 1330 - 1430   | 4     |
| 1345 - 1400 | 0                                 | 0  | 0   | 0   | 0    | 0    | 0   | 0     | 1345 - 1445   | 5     |
| 1400 - 1415 | 0                                 | 0  | 0   | 2   | 0    | 0    | 0   | 2     | 1400 - 1500   | 5     |
| 1415 - 1430 | 0                                 | 0  | 0   | 2   | 0    | 0    | 0   | 2     | 1415 - 1515   | 3     |
| 1430 - 1445 | 0                                 | 0  | 1   | 0   | 0    | 0    | 0   | 1     | 1430 - 1530   | 1     |
| 1445 - 1500 | 0                                 | 0  | 0   | 0   | 0    | 0    | 0   | 0     | 1445 - 1545   | 0     |
| 1500 - 1515 | 0                                 | 0  | 0   | 0   | 0    | 0    | 0   | 0     | 1500 - 1600   | 0     |
| 1515 - 1530 | 0                                 | 0  | 0   | 0   | 0    | 0    | 0   | 0     | 1515 - 1615   | 0     |
| 1530 - 1545 | 0                                 | 0  | 0   | 0   | 0    | 0    | 0   | 0     | 1530 - 1630   | 1     |
| 1545 - 1600 | 0                                 | 0  | 0   | 0   | 0    | 0    | 0   | 0     | 1545 - 1645   | 1     |
| 1600 - 1615 | 0                                 | 0  | 0   | 0   | 0    | 0    | 0   | 0     | 1600 - 1700   | 2     |
| 1615 - 1630 | 0                                 | 0  | 0   | 1   | 0    | 0    | 0   | 1     | 1615 - 1715   | 2     |
| 1630 - 1645 | 0                                 | 0  | 0   | 0   | 0    | 0    | 0   | 0     | 1630 - 1730   | 1     |
| 1645 - 1700 | 0                                 | 0  | 0   | 1   | 0    | 0    | 0   | 1     | 1645 - 1745   | 1     |
| 1700 - 1715 | 0                                 | 0  | 0   | 0   | 0    | 0    | 0   | 0     | 1700 - 1800   | 0     |
| 1715 - 1730 | 0                                 | 0  | 0   | 0   | 0    | 0    | 0   | 0     | 1715 - 1815   | 0     |
| 1730 - 1745 | 0                                 | 0  | 0   | 0   | 0    | 0    | 0   | 0     | 1730 - 1830   | 0     |
| 1745 - 1800 | 0                                 | 0  | 0   | 0   | 0    | 0    | 0   | 0     | 1745 - 1845   | 0     |
| 1800 - 1815 | 0                                 | 0  | 0   | 0   | 0    | 0    | 0   | 0     | 1800 - 1900   | 1     |
| 1815 - 1830 | 0                                 | 0  | 0   | 0   | 0    | 0    | 0   | 0     |               |       |
| 1830 - 1845 | 0                                 | 0  | 0   | 0   | 0    | 0    | 0   | 0     |               |       |
| 1845 - 1900 | 1                                 | 0  | 0   | 0   | 0    | 0    | 0   | 1     |               |       |

**TSUK**

Gordon St, London  
 Tuesday 08 October 2013  
**Service Entrance**

| Time        | SE3 - Left to Gordon St, North |    |     |     |      |      |     |       | Hourly Totals |       |
|-------------|--------------------------------|----|-----|-----|------|------|-----|-------|---------------|-------|
|             | PC                             | MC | CAR | LGV | OGV1 | OGV2 | PSV | Total | Hourly        | Total |
| 0700 - 0715 | 0                              | 0  | 0   | 0   | 0    | 0    | 0   | 0     | 0700 - 0800   | 2     |
| 0715 - 0730 | 0                              | 0  | 0   | 1   | 0    | 0    | 0   | 1     | 0715 - 0815   | 3     |
| 0730 - 0745 | 0                              | 0  | 0   | 0   | 1    | 0    | 0   | 1     | 0730 - 0830   | 4     |
| 0745 - 0800 | 0                              | 0  | 0   | 0   | 0    | 0    | 0   | 0     | 0745 - 0845   | 3     |
| 0800 - 0815 | 0                              | 0  | 0   | 1   | 0    | 0    | 0   | 1     | 0800 - 0900   | 5     |
| 0815 - 0830 | 0                              | 0  | 0   | 0   | 2    | 0    | 0   | 2     | 0815 - 0915   | 4     |
| 0830 - 0845 | 0                              | 0  | 0   | 0   | 0    | 0    | 0   | 0     | 0830 - 0930   | 2     |
| 0845 - 0900 | 0                              | 0  | 1   | 1   | 0    | 0    | 0   | 2     | 0845 - 0945   | 3     |
| 0900 - 0915 | 0                              | 0  | 0   | 0   | 0    | 0    | 0   | 0     | 0900 - 1000   | 2     |
| 0915 - 0930 | 0                              | 0  | 0   | 0   | 0    | 0    | 0   | 0     | 0915 - 1015   | 3     |
| 0930 - 0945 | 0                              | 0  | 0   | 1   | 0    | 0    | 0   | 1     | 0930 - 1030   | 3     |
| 0945 - 1000 | 0                              | 0  | 0   | 1   | 0    | 0    | 0   | 1     | 0945 - 1045   | 2     |
| 1000 - 1015 | 0                              | 0  | 0   | 1   | 0    | 0    | 0   | 1     | 1000 - 1100   | 2     |
| 1015 - 1030 | 0                              | 0  | 0   | 0   | 0    | 0    | 0   | 0     | 1015 - 1115   | 1     |
| 1030 - 1045 | 0                              | 0  | 0   | 0   | 0    | 0    | 0   | 0     | 1030 - 1130   | 3     |
| 1045 - 1100 | 0                              | 0  | 0   | 1   | 0    | 0    | 0   | 1     | 1045 - 1145   | 3     |
| 1100 - 1115 | 0                              | 0  | 0   | 0   | 0    | 0    | 0   | 0     | 1100 - 1200   | 3     |
| 1115 - 1130 | 1                              | 0  | 0   | 1   | 0    | 0    | 0   | 2     | 1115 - 1215   | 3     |
| 1130 - 1145 | 0                              | 0  | 0   | 0   | 0    | 0    | 0   | 0     | 1130 - 1230   | 1     |
| 1145 - 1200 | 0                              | 0  | 0   | 1   | 0    | 0    | 0   | 1     | 1145 - 1245   | 2     |
| 1200 - 1215 | 0                              | 0  | 0   | 0   | 0    | 0    | 0   | 0     | 1200 - 1300   | 1     |
| 1215 - 1230 | 0                              | 0  | 0   | 0   | 0    | 0    | 0   | 0     | 1215 - 1315   | 2     |
| 1230 - 1245 | 0                              | 0  | 0   | 1   | 0    | 0    | 0   | 1     | 1230 - 1330   | 4     |
| 1245 - 1300 | 0                              | 0  | 0   | 0   | 0    | 0    | 0   | 0     | 1245 - 1345   | 4     |
| 1300 - 1315 | 0                              | 0  | 0   | 1   | 0    | 0    | 0   | 1     | 1300 - 1400   | 5     |
| 1315 - 1330 | 1                              | 0  | 0   | 0   | 1    | 0    | 0   | 2     | 1315 - 1415   | 4     |
| 1330 - 1345 | 0                              | 0  | 0   | 1   | 0    | 0    | 0   | 1     | 1330 - 1430   | 2     |
| 1345 - 1400 | 0                              | 0  | 0   | 1   | 0    | 0    | 0   | 1     | 1345 - 1445   | 2     |
| 1400 - 1415 | 0                              | 0  | 0   | 0   | 0    | 0    | 0   | 0     | 1400 - 1500   | 2     |
| 1415 - 1430 | 0                              | 0  | 0   | 0   | 0    | 0    | 0   | 0     | 1415 - 1515   | 3     |
| 1430 - 1445 | 0                              | 0  | 0   | 1   | 0    | 0    | 0   | 1     | 1430 - 1530   | 3     |
| 1445 - 1500 | 0                              | 0  | 0   | 1   | 0    | 0    | 0   | 1     | 1445 - 1545   | 2     |
| 1500 - 1515 | 0                              | 0  | 1   | 0   | 0    | 0    | 0   | 1     | 1500 - 1600   | 1     |
| 1515 - 1530 | 0                              | 0  | 0   | 0   | 0    | 0    | 0   | 0     | 1515 - 1615   | 0     |
| 1530 - 1545 | 0                              | 0  | 0   | 0   | 0    | 0    | 0   | 0     | 1530 - 1630   | 0     |
| 1545 - 1600 | 0                              | 0  | 0   | 0   | 0    | 0    | 0   | 0     | 1545 - 1645   | 0     |
| 1600 - 1615 | 0                              | 0  | 0   | 0   | 0    | 0    | 0   | 0     | 1600 - 1700   | 0     |
| 1615 - 1630 | 0                              | 0  | 0   | 0   | 0    | 0    | 0   | 0     | 1615 - 1715   | 1     |
| 1630 - 1645 | 0                              | 0  | 0   | 0   | 0    | 0    | 0   | 0     | 1630 - 1730   | 1     |
| 1645 - 1700 | 0                              | 0  | 0   | 0   | 0    | 0    | 0   | 0     | 1645 - 1745   | 1     |
| 1700 - 1715 | 1                              | 0  | 0   | 0   | 0    | 0    | 0   | 1     | 1700 - 1800   | 1     |
| 1715 - 1730 | 0                              | 0  | 0   | 0   | 0    | 0    | 0   | 0     | 1715 - 1815   | 0     |
| 1730 - 1745 | 0                              | 0  | 0   | 0   | 0    | 0    | 0   | 0     | 1730 - 1830   | 0     |
| 1745 - 1800 | 0                              | 0  | 0   | 0   | 0    | 0    | 0   | 0     | 1745 - 1845   | 1     |
| 1800 - 1815 | 0                              | 0  | 0   | 0   | 0    | 0    | 0   | 0     | 1800 - 1900   | 2     |
| 1815 - 1830 | 0                              | 0  | 0   | 0   | 0    | 0    | 0   | 0     |               |       |
| 1830 - 1845 | 1                              | 0  | 0   | 0   | 0    | 0    | 0   | 1     |               |       |
| 1845 - 1900 | 1                              | 0  | 0   | 0   | 0    | 0    | 0   | 1     |               |       |

**TSUK**

Gordon St, London  
 Tuesday 08 October 2013  
**Service Entrance**

| Time        | SE4 - Right to Gordon St, South |    |     |     |      |      |     |       | Hourly Totals |       |
|-------------|---------------------------------|----|-----|-----|------|------|-----|-------|---------------|-------|
|             | PC                              | MC | CAR | LGV | OGV1 | OGV2 | PSV | Total | Hourly        | Total |
| 0700 - 0715 | 0                               | 0  | 0   | 0   | 0    | 0    | 0   | 0     | 0700 - 0800   | 2     |
| 0715 - 0730 | 0                               | 0  | 0   | 0   | 0    | 0    | 0   | 0     | 0715 - 0815   | 3     |
| 0730 - 0745 | 0                               | 0  | 0   | 0   | 0    | 0    | 0   | 0     | 0730 - 0830   | 5     |
| 0745 - 0800 | 0                               | 0  | 0   | 2   | 0    | 0    | 0   | 2     | 0745 - 0845   | 5     |
| 0800 - 0815 | 0                               | 0  | 0   | 1   | 0    | 0    | 0   | 1     | 0800 - 0900   | 3     |
| 0815 - 0830 | 1                               | 0  | 0   | 1   | 0    | 0    | 0   | 2     | 0815 - 0915   | 2     |
| 0830 - 0845 | 0                               | 0  | 0   | 0   | 0    | 0    | 0   | 0     | 0830 - 0930   | 0     |
| 0845 - 0900 | 0                               | 0  | 0   | 0   | 0    | 0    | 0   | 0     | 0845 - 0945   | 4     |
| 0900 - 0915 | 0                               | 0  | 0   | 0   | 0    | 0    | 0   | 0     | 0900 - 1000   | 5     |
| 0915 - 0930 | 0                               | 0  | 0   | 0   | 0    | 0    | 0   | 0     | 0915 - 1015   | 5     |
| 0930 - 0945 | 0                               | 0  | 0   | 4   | 0    | 0    | 0   | 4     | 0930 - 1030   | 5     |
| 0945 - 1000 | 0                               | 0  | 1   | 0   | 0    | 0    | 0   | 1     | 0945 - 1045   | 1     |
| 1000 - 1015 | 0                               | 0  | 0   | 0   | 0    | 0    | 0   | 0     | 1000 - 1100   | 0     |
| 1015 - 1030 | 0                               | 0  | 0   | 0   | 0    | 0    | 0   | 0     | 1015 - 1115   | 1     |
| 1030 - 1045 | 0                               | 0  | 0   | 0   | 0    | 0    | 0   | 0     | 1030 - 1130   | 1     |
| 1045 - 1100 | 0                               | 0  | 0   | 0   | 0    | 0    | 0   | 0     | 1045 - 1145   | 1     |
| 1100 - 1115 | 0                               | 0  | 0   | 1   | 0    | 0    | 0   | 1     | 1100 - 1200   | 3     |
| 1115 - 1130 | 0                               | 0  | 0   | 0   | 0    | 0    | 0   | 0     | 1115 - 1215   | 2     |
| 1130 - 1145 | 0                               | 0  | 0   | 0   | 0    | 0    | 0   | 0     | 1130 - 1230   | 4     |
| 1145 - 1200 | 0                               | 0  | 0   | 2   | 0    | 0    | 0   | 2     | 1145 - 1245   | 5     |
| 1200 - 1215 | 0                               | 0  | 0   | 0   | 0    | 0    | 0   | 0     | 1200 - 1300   | 3     |
| 1215 - 1230 | 1                               | 0  | 0   | 1   | 0    | 0    | 0   | 2     | 1215 - 1315   | 4     |
| 1230 - 1245 | 0                               | 0  | 0   | 1   | 0    | 0    | 0   | 1     | 1230 - 1330   | 3     |
| 1245 - 1300 | 0                               | 0  | 0   | 0   | 0    | 0    | 0   | 0     | 1245 - 1345   | 3     |
| 1300 - 1315 | 0                               | 0  | 0   | 1   | 0    | 0    | 0   | 1     | 1300 - 1400   | 3     |
| 1315 - 1330 | 0                               | 0  | 0   | 1   | 0    | 0    | 0   | 1     | 1315 - 1415   | 3     |
| 1330 - 1345 | 1                               | 0  | 0   | 0   | 0    | 0    | 0   | 1     | 1330 - 1430   | 6     |
| 1345 - 1400 | 0                               | 0  | 0   | 0   | 0    | 0    | 0   | 0     | 1345 - 1445   | 6     |
| 1400 - 1415 | 0                               | 0  | 0   | 1   | 0    | 0    | 0   | 1     | 1400 - 1500   | 7     |
| 1415 - 1430 | 1                               | 0  | 0   | 3   | 0    | 0    | 0   | 4     | 1415 - 1515   | 6     |
| 1430 - 1445 | 1                               | 0  | 0   | 0   | 0    | 0    | 0   | 1     | 1430 - 1530   | 2     |
| 1445 - 1500 | 0                               | 0  | 0   | 1   | 0    | 0    | 0   | 1     | 1445 - 1545   | 1     |
| 1500 - 1515 | 0                               | 0  | 0   | 0   | 0    | 0    | 0   | 0     | 1500 - 1600   | 0     |
| 1515 - 1530 | 0                               | 0  | 0   | 0   | 0    | 0    | 0   | 0     | 1515 - 1615   | 0     |
| 1530 - 1545 | 0                               | 0  | 0   | 0   | 0    | 0    | 0   | 0     | 1530 - 1630   | 2     |
| 1545 - 1600 | 0                               | 0  | 0   | 0   | 0    | 0    | 0   | 0     | 1545 - 1645   | 3     |
| 1600 - 1615 | 0                               | 0  | 0   | 0   | 0    | 0    | 0   | 0     | 1600 - 1700   | 8     |
| 1615 - 1630 | 0                               | 0  | 1   | 1   | 0    | 0    | 0   | 2     | 1615 - 1715   | 8     |
| 1630 - 1645 | 1                               | 0  | 0   | 0   | 0    | 0    | 0   | 1     | 1630 - 1730   | 8     |
| 1645 - 1700 | 4                               | 0  | 0   | 1   | 0    | 0    | 0   | 5     | 1645 - 1745   | 9     |
| 1700 - 1715 | 0                               | 0  | 0   | 0   | 0    | 0    | 0   | 0     | 1700 - 1800   | 5     |
| 1715 - 1730 | 2                               | 0  | 0   | 0   | 0    | 0    | 0   | 2     | 1715 - 1815   | 6     |
| 1730 - 1745 | 2                               | 0  | 0   | 0   | 0    | 0    | 0   | 2     | 1730 - 1830   | 5     |
| 1745 - 1800 | 1                               | 0  | 0   | 0   | 0    | 0    | 0   | 1     | 1745 - 1845   | 3     |
| 1800 - 1815 | 1                               | 0  | 0   | 0   | 0    | 0    | 0   | 1     | 1800 - 1900   | 3     |
| 1815 - 1830 | 1                               | 0  | 0   | 0   | 0    | 0    | 0   | 1     |               |       |
| 1830 - 1845 | 0                               | 0  | 0   | 0   | 0    | 0    | 0   | 0     |               |       |
| 1845 - 1900 | 1                               | 0  | 0   | 0   | 0    | 0    | 0   | 1     |               |       |

## **A11. SWEPT PATH ANALYSIS**

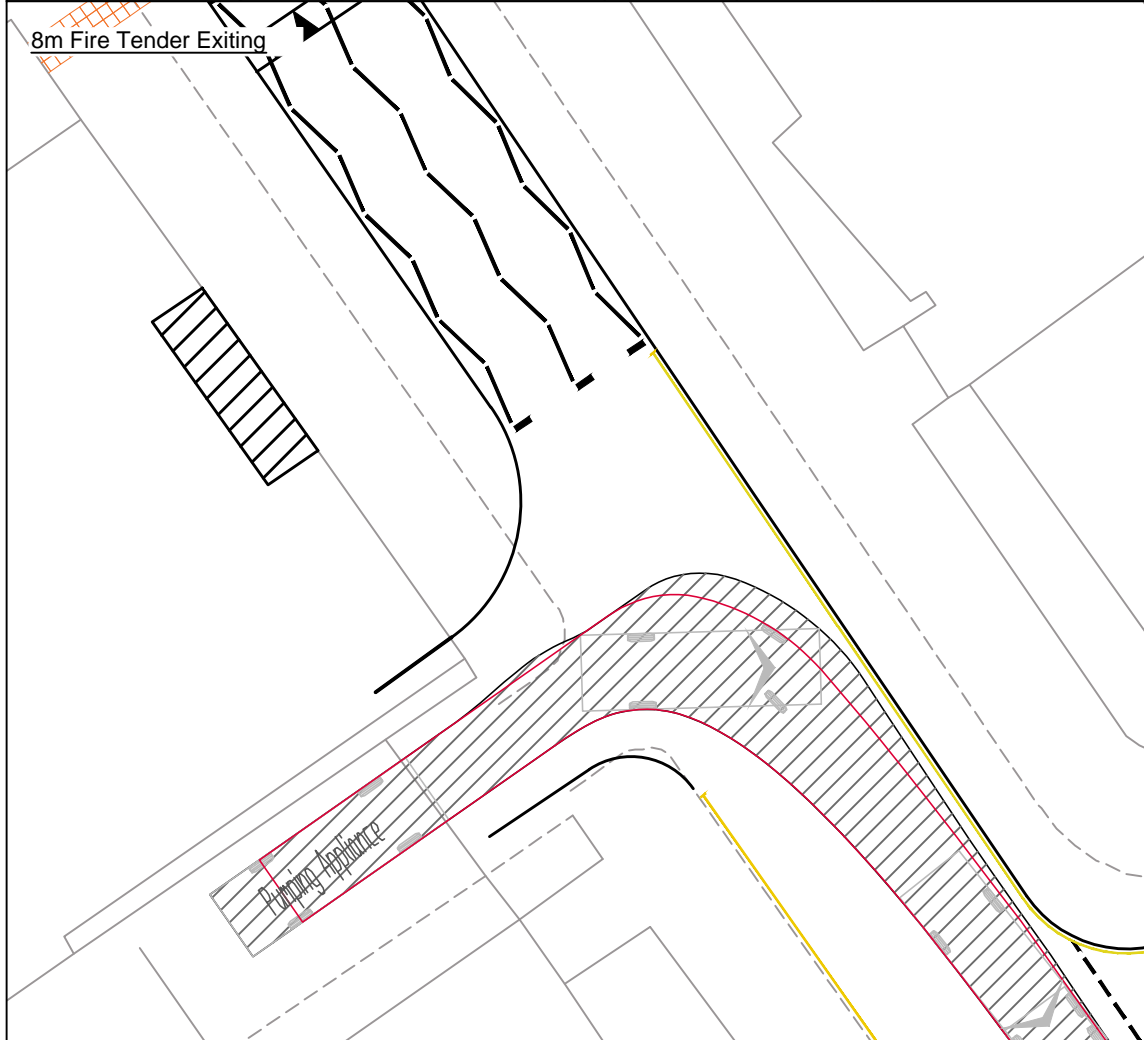
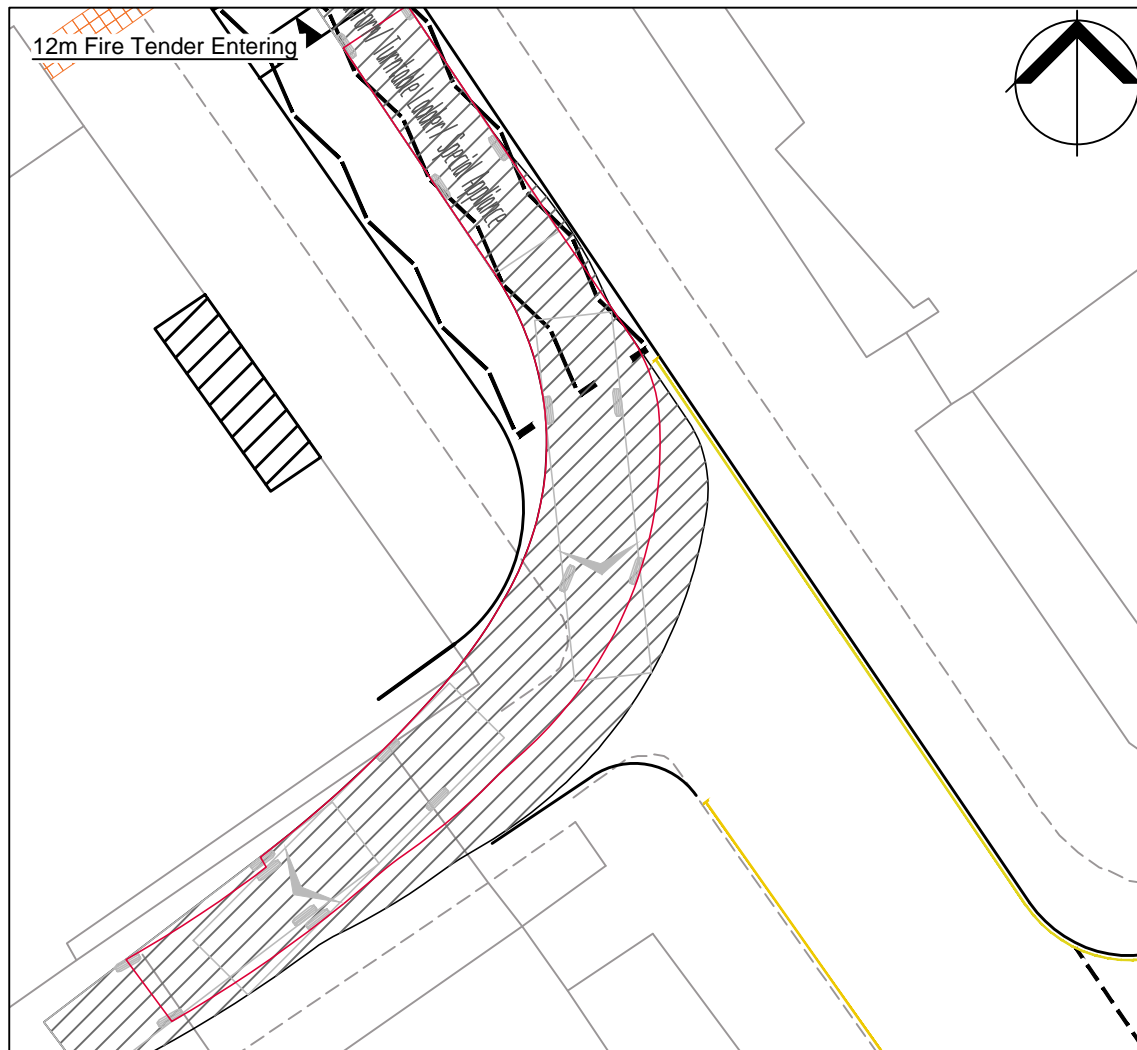
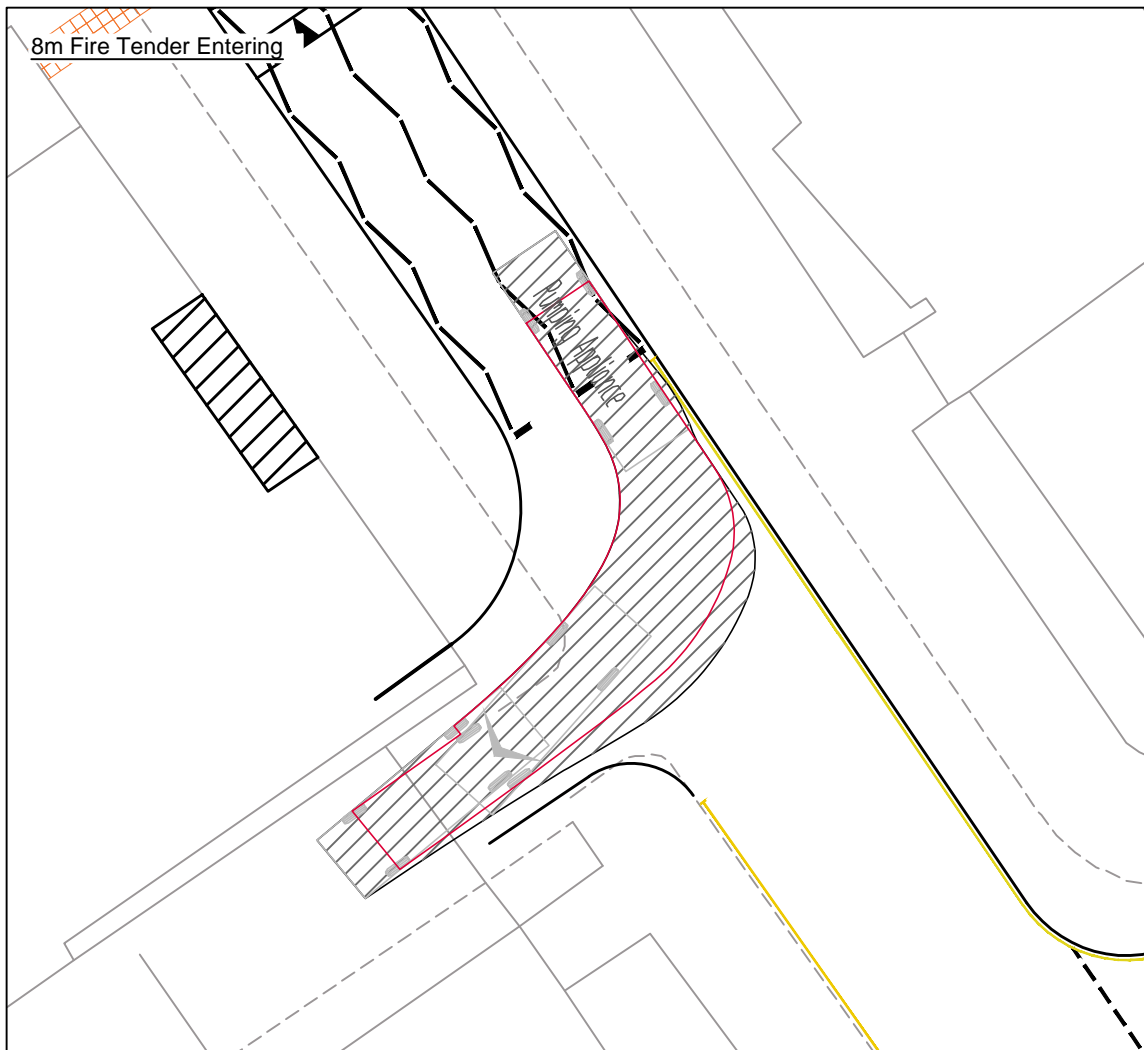

- Notes;
1. Based upon the Ordnance Survey's (1:1250) Map with permission of the controller of Her Majesty's Stationery Office, Crown copyright reserved.
  2. The crossings shown have been designed in accordance with 'The Zebra, Pelican and Puffin Pedestrian Crossings Regulations and General Directions 1997' document.

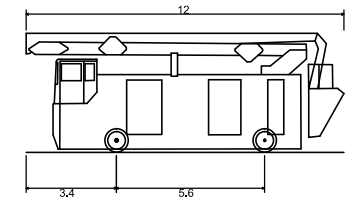

|  |         |
|--|---------|
| Aerial Platform/ Turntable Ladder/ Special Appliance |         |
| Overall Length                                       | 12.000m |
| Overall Width  | 2.550m  |
| Overall Body Height                                  | 4.500m  |
| Min Body Ground Clearance                            | 0.130m  |
| Track Width  | 2.550m  |
| Lock to Lock Time                                    | 4.00s   |
| Kerb to Kerb Turning Radius                          | 13.750m |

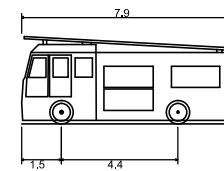

|                             |        |
|-----------------------------|--------|
| Pumping Appliance           |        |
| Overall Length              | 7.900m |
| Overall Width               | 2.500m |
| Overall Body Height         | 3.300m |
| Min Body Ground Clearance   | 0.140m |
| Track Width                 | 2.500m |
| Lock to Lock Time           | 4.00s  |
| Kerb to Kerb Turning Radius | 7.750m |

| Rev | Date     | Amendments     | Drawn | Chk | App |
|-----|----------|----------------|-------|-----|-----|
| A   | 18.05.15 | Access Amended | RB    | FP  | FP  |

**Iceni Projects**  
 Flitcroft House  
 114-116 Charing Cross Road  
 London, WC2H 0JR



T 020 3640 8508  
 F 020 3435 4228  
 mail@iceniprojects.com



Client \_\_\_\_\_

University College London (UCL) Estates

Project \_\_\_\_\_

Student Centre, Gordon Street, London

Title \_\_\_\_\_

Swept Path Analysis

|          |            |             |
|----------|------------|-------------|
| Drawn By | Checked By | Approved By |
| RB       | FP         | FP          |
|          | 08.05.2015 | 08.05.2015  |

|            |            |
|------------|------------|
| Scale @ A3 | Date       |
| 1:250      | 08.05.2015 |

|             |             |      |
|-------------|-------------|------|
| Project No. | Drawing No. | Rev. |
| 13-T097     | 07A         | A    |

## **A12. ENVIRONMENTAL SURVEY RESULTS**

| Mode of Travel  | Staff Survey |            |          |          |       | Student Survey |            |          |          |       |
|---|--------------|------------|----------|----------|-------|----------------|------------|----------|----------|-------|
|   | Respondents  | Percentage | Proposed | Adjusted |       | Respondents    | Percentage | Proposed | Adjusted |       |
| A car or van as a driver  | 42           | 3.1%       | 3        | 0        | 0.0%  | 7              | 0.7%       | 7        | 0        | 0.0%  |
| A car or van as a passenger   | 31           | 2.3%       | 3        | 3        | 2.3%  | 10             | 1.0%       | 10       | 10       | 1.0%  |
| A motorbike, moped or scooter   | 8            | 0.6%       | 1        | 1        | 0.6%  | 4              | 0.4%       | 4        | 4        | 0.4%  |
| A bicycle you own, borrow or hire (not from Barclays Cycle Hire Scheme) | 121          | 8.8%       | 10       | 10       | 9.1%  | 95             | 9.2%       | 96       | 97       | 9.3%  |
| A bicycle hired from the Barclays Cycle Scheme                          | 11           | 0.8%       | 1        | 1        | 0.8%  | 16             | 1.6%       | 16       | 16       | 1.6%  |
| Microscooter/board/blade  | 0            | 0.0%       | 0        | 0        | 0.0%  | 1              | 0.1%       | 1        | 1        | 0.1%  |
| Walk  | 422          | 30.8%      | 34       | 36       | 31.8% | 427            | 41.5%      | 432      | 435      | 41.7% |
| Bus   | 161          | 11.8%      | 13       | 14       | 12.1% | 123            | 11.9%      | 124      | 125      | 12.0% |
| Underground   | 314          | 22.9%      | 26       | 26       | 23.6% | 245            | 23.8%      | 248      | 250      | 23.9% |
| DLR   | 6            | 0.4%       | 0        | 1        | 0.5%  | 8              | 0.8%       | 8        | 8        | 0.8%  |
| Riverboat   | 2            | 0.1%       | 0        | 0        | 0.2%  | 2              | 0.2%       | 2        | 2        | 0.2%  |
| Tram  | 0            | 0.0%       | 0        | 0        | 0.0%  | 3              | 0.3%       | 3        | 3        | 0.3%  |
| Overland trains   | 252          | 18.4%      | 21       | 21       | 19.0% | 89             | 8.6%       | 90       | 91       | 8.7%  |
|   | 1370         |            | 112      |          |       | 1030           |            | 1042     |          |       |