

DO5_A - EAVES

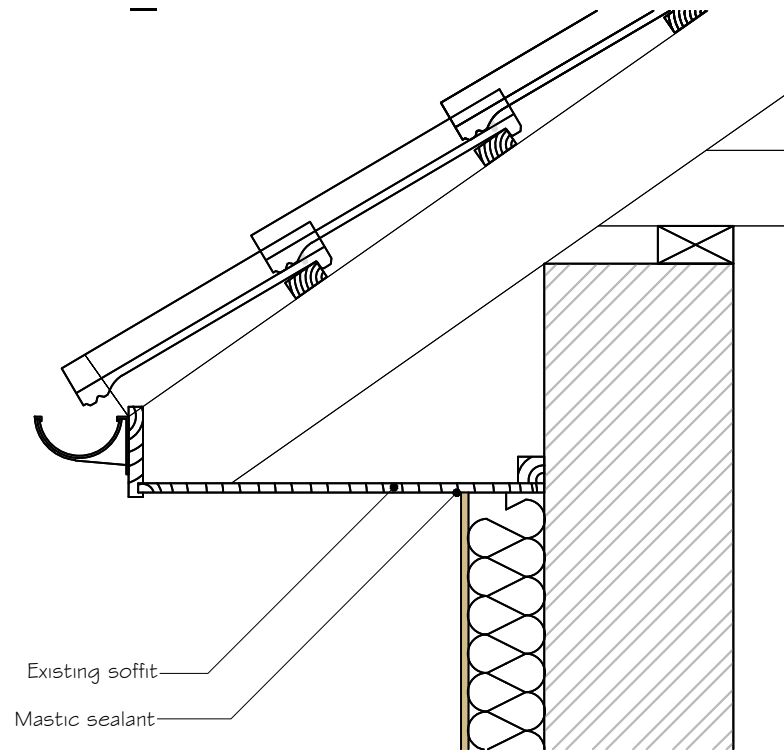

DO5_B - BALCONY DOOR

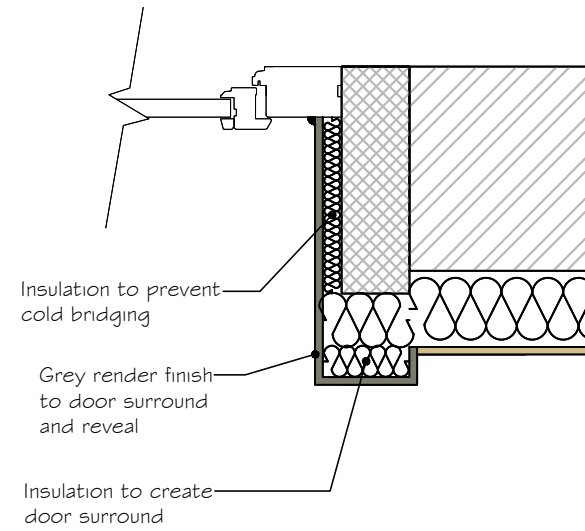

DO5_C - BUTTRESS DETAIL

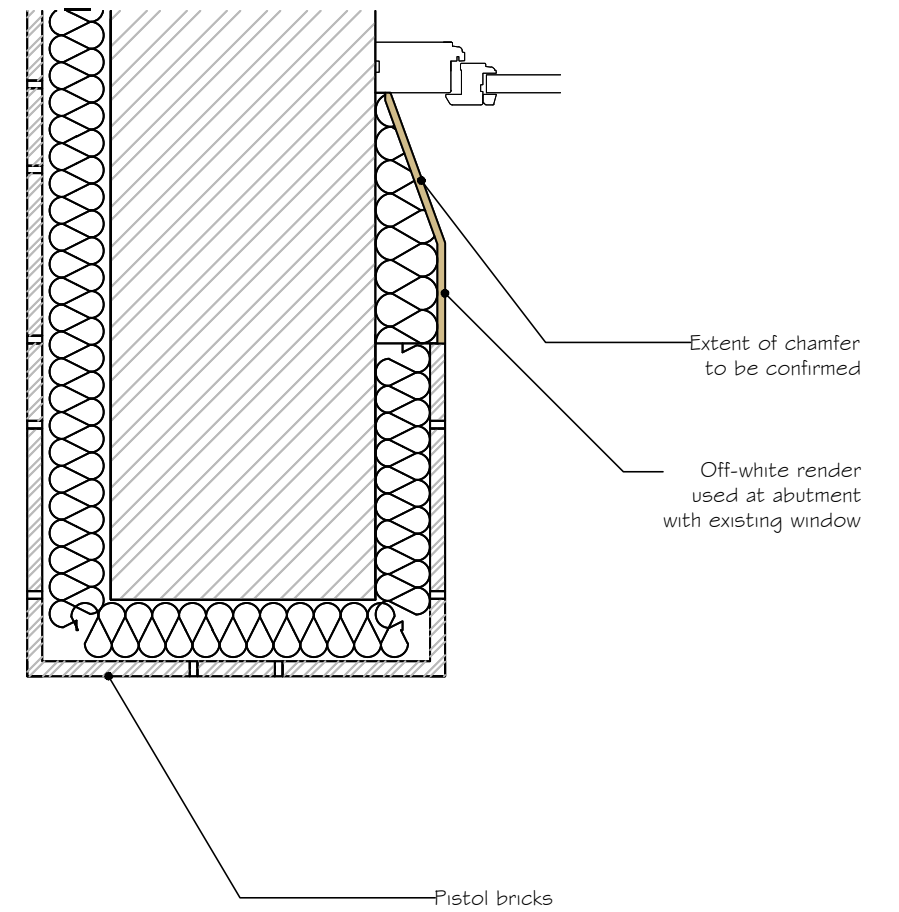

DO5_D - BRICK SLIPS BASE

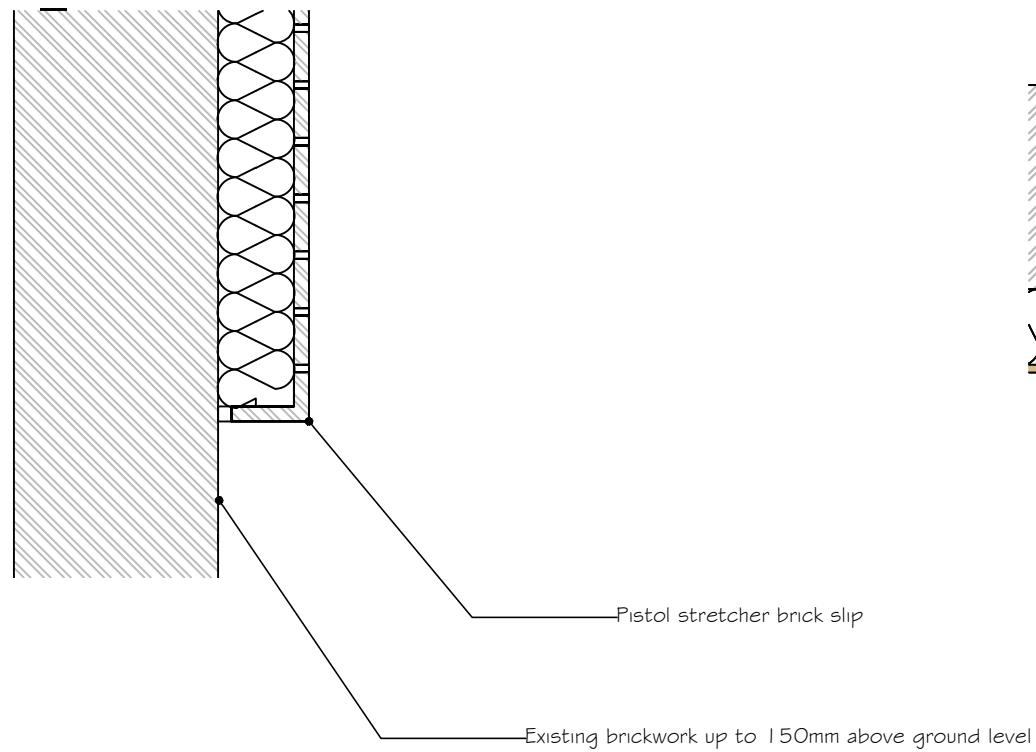

DO5_E - ENTRANCE DOOR

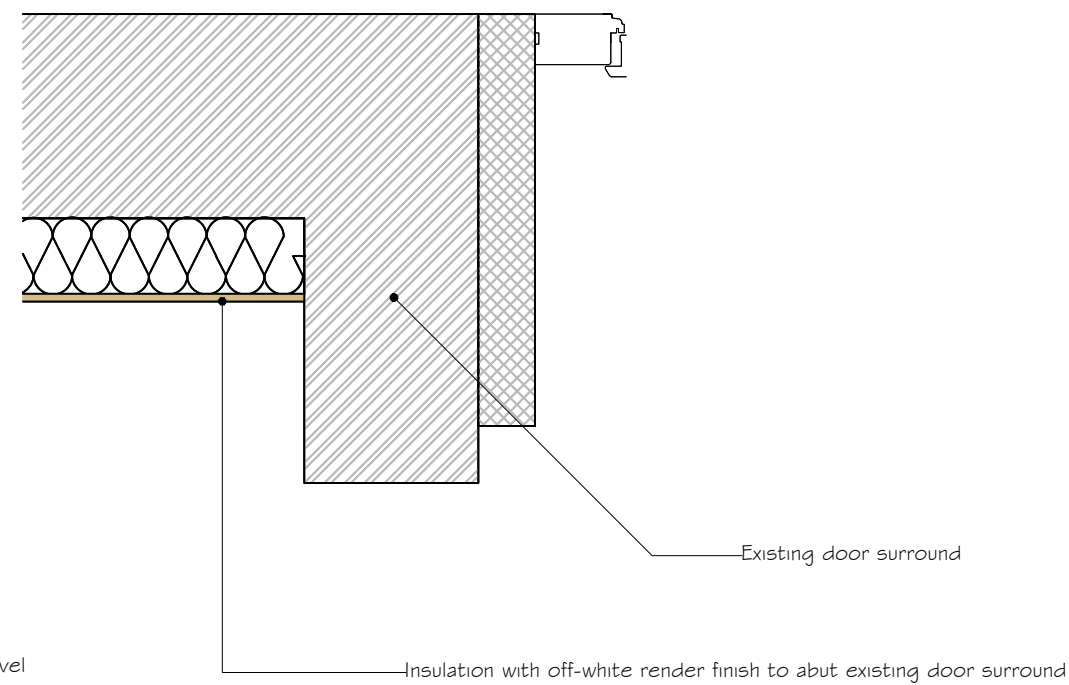

Archetype 5 - Proposed Details
Scale 1:10 & 1:20 @ A-3

Ref:1325/PS/HE/D/05

17-24 Dobson Close
Hilgrove Estate
London
NW6 4RS



Client: Lakehouse



Drawn by: SF
Date: June 2015

pod LLP
Unit 313
Metal Box Factory
30 Great Guildford Street
London
SE1 0HS



Tel: 020 3176 5590
Mob: 07808 037 998
Email: simon@podpartnership.com
Web: www.podpartnership.com