

DOI_A BUTTRESS PLAN

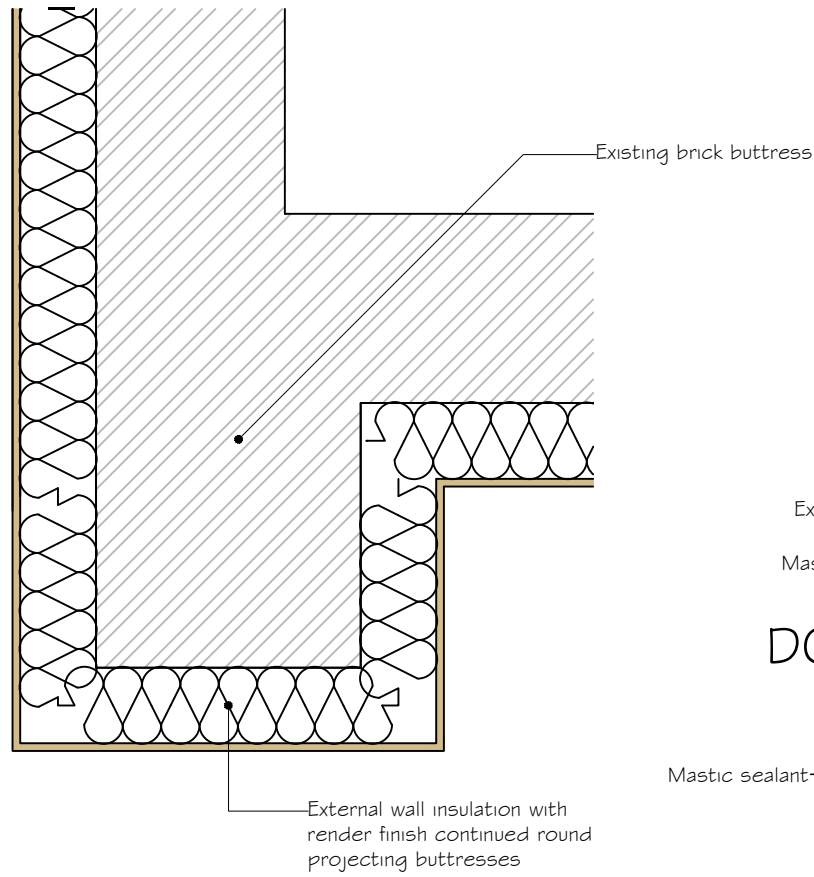

DOI_B - EAVES

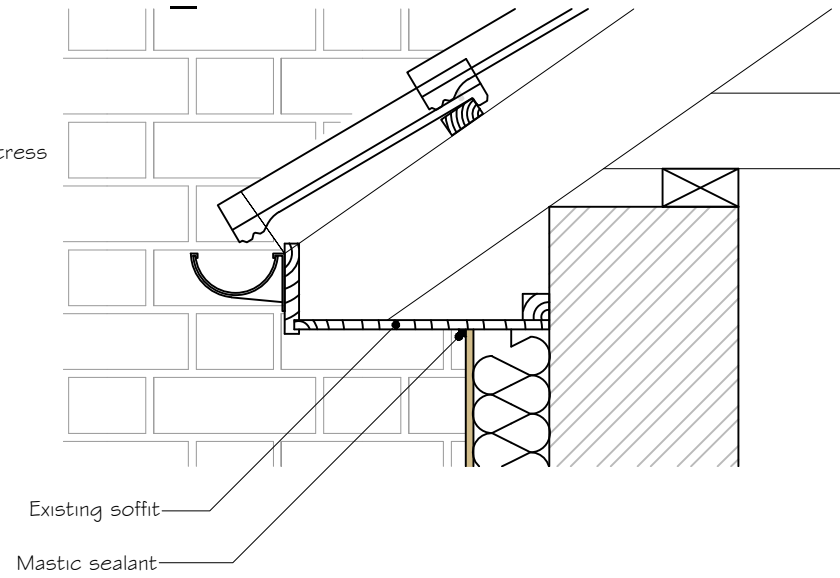

DOI_C - BUTTRESS EAVES

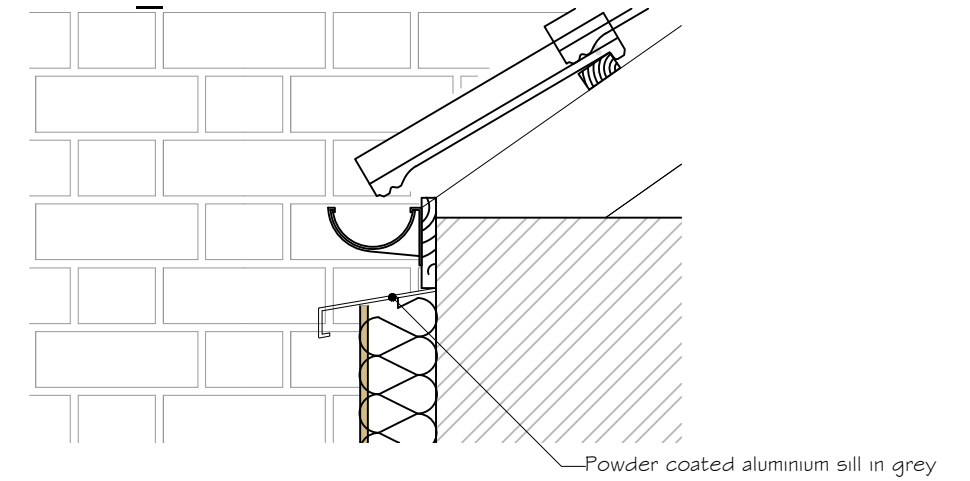

DOI_D - WINDOW JAMB

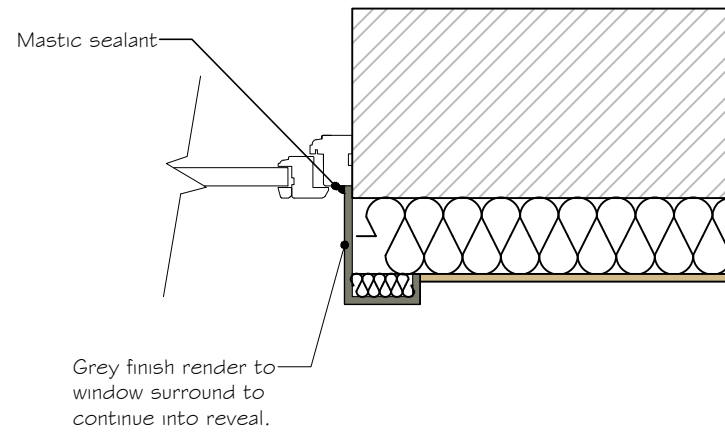

DOI_E - WINDOW HEAD

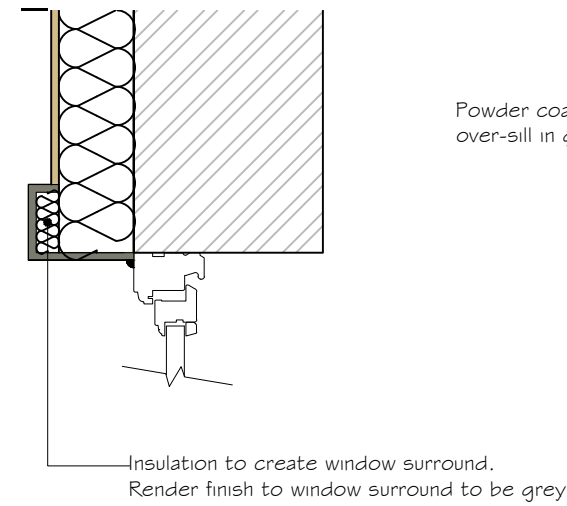

DOI_F - WINDOW SILL

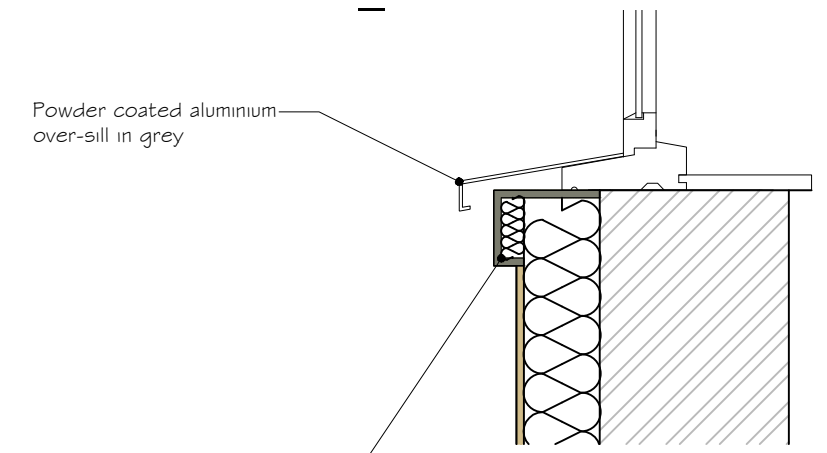

DOI_G - ENTRANCE DETAIL

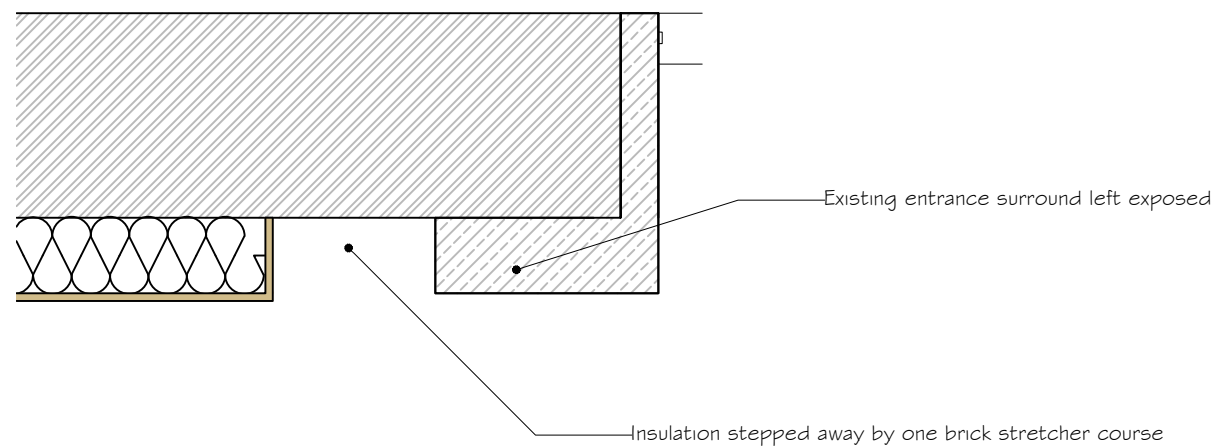

Archetype 1 - Proposed Details
Scale 1:10 @ A-3

Ref:1325/PS/HE/D/01

Nos. 25 - 48
Hilgrove Estate
London
NW6 4RT



Client: Lakehouse



Drawn by: SF
Date: June 2015

pod LLP
Unit 313
Metal Box Factory
30 Great Guildford Street
London
SE1 0HS



Tel: 020 3176 5590
Mob: 07808 037 998
Email: simon@podpartnership.com
Web: www.podpartnership.com

- This drawing is for planning purposes only.
 - All dimensions to be verified on site.
 - To be read in conjunction with specialist supplier's details and specifications.
 - Any discrepancies are to be notified to pod LLP immediately.
 - This document is copyright of pod LLP.