

TIMBER GROUND FIXED TO SOFFIT PANEL

SECONDARY GLAZING IN ALUMINIUM FRAMED VERTICAL SLIDING UNITS PAINTED WHITE AND FIXED VIA MOULDED HARDWOOD GROUNDS TO EXISTING JOINERY
INDICATIVE SPECIFICATION: SELECTAGLAZE
- SERIES 90 FOR FRONT FACING WINDOWS @ FIRST FLOOR (APPROX. 3500mm HIGH)
- SERIES 20 FOR ALL OTHER WINDOWS (LESS THAN 3000mm HIGH)

EXISTING TIMBER WINDOWS TO BE REFURBISHED, CHECKED FOR PROPER OPERATION AND REDECORATED

HEAD DETAIL USING SERIES 20 UNITS AT THIRD FLOOR DORMER

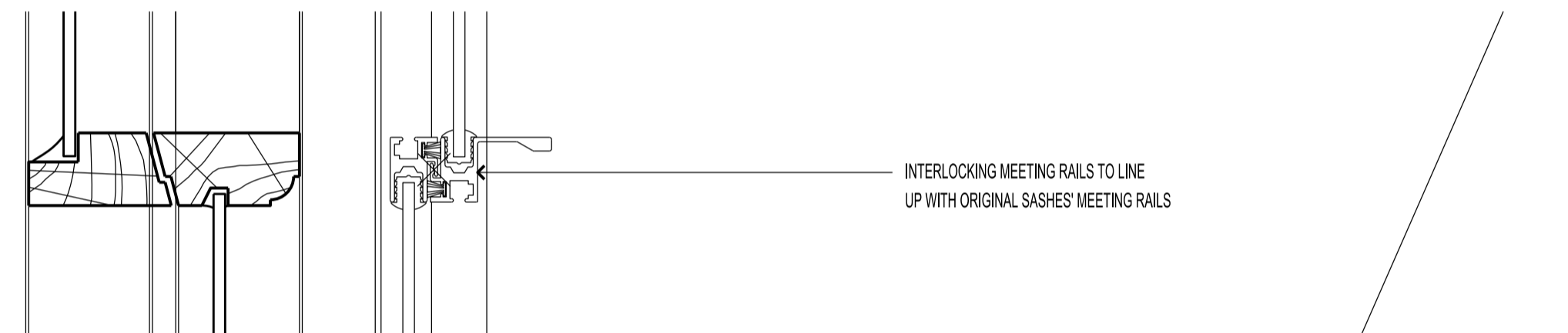

INTERLOCKING MEETING RAILS TO LINE UP WITH ORIGINAL SASHES' MEETING RAILS

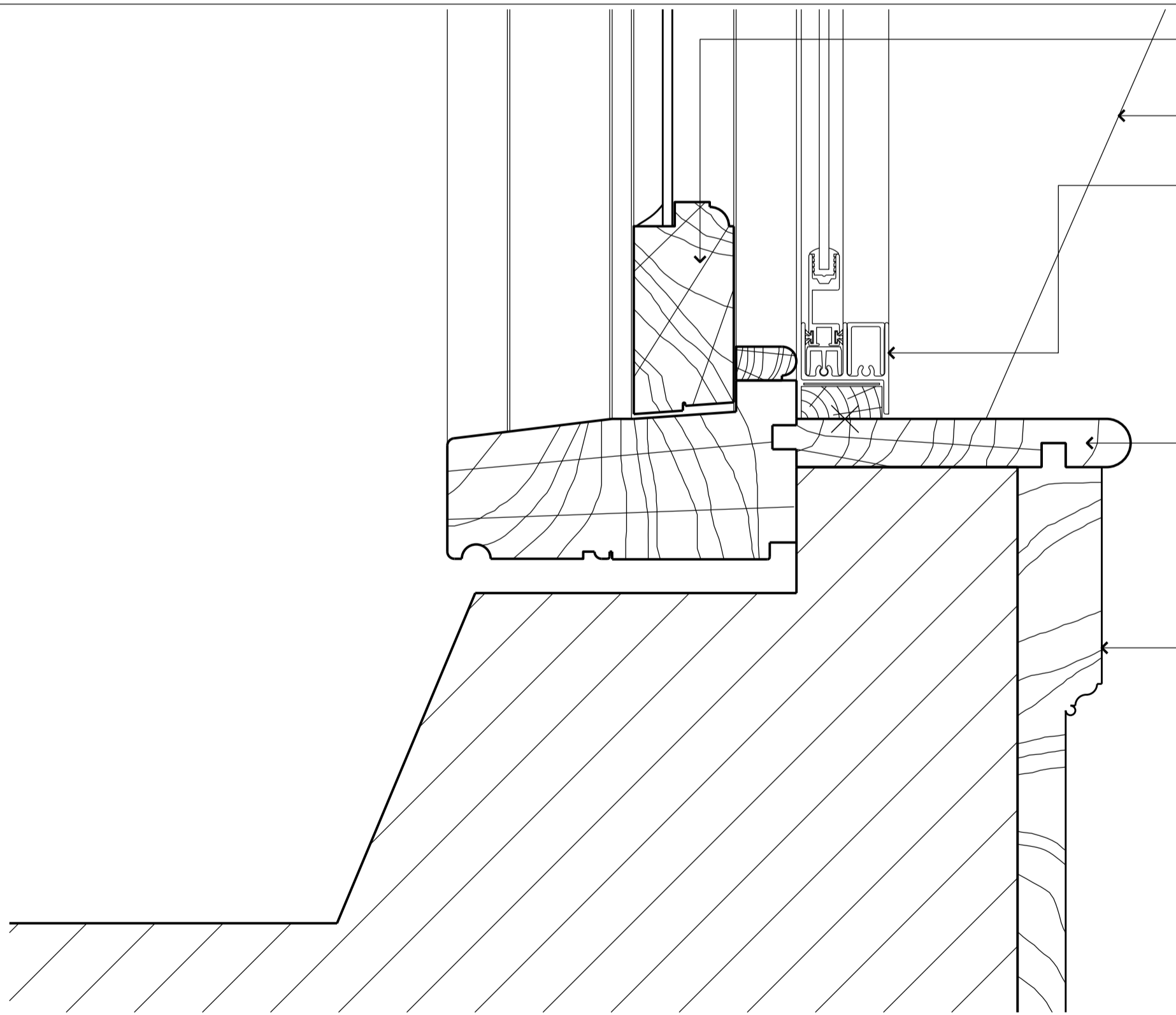

EXISTING TIMBER WINDOWS TO BE REFURBISHED, CHECKED FOR PROPER OPERATION AND REDECORATED

SLOPING LINE OF DORMER REVEAL

SECONDARY GLAZING IN ALUMINIUM FRAMED VERTICAL SLIDING UNITS PAINTED WHITE AND FIXED VIA MOULDED HARDWOOD GROUNDS TO EXISTING JOINERY
INDICATIVE SPECIFICATION: SELECTAGLAZE
- SERIES 90 FOR FRONT FACING WINDOWS @ FIRST FLOOR (APPROX. 3500mm HIGH)
- SERIES 20 FOR ALL OTHER WINDOWS (LESS THAN 3000mm HIGH)

EXISTING TIMBER CILL RETAINED AND REDECORATED
NOTE: CILLS WIDTH VARIES

EXISTING TIMBER PANELS TO BE REFURBISHED AND REDECORATED

CILL DETAIL USING SERIES 20 UNITS AT THIRD FLOOR DORMER

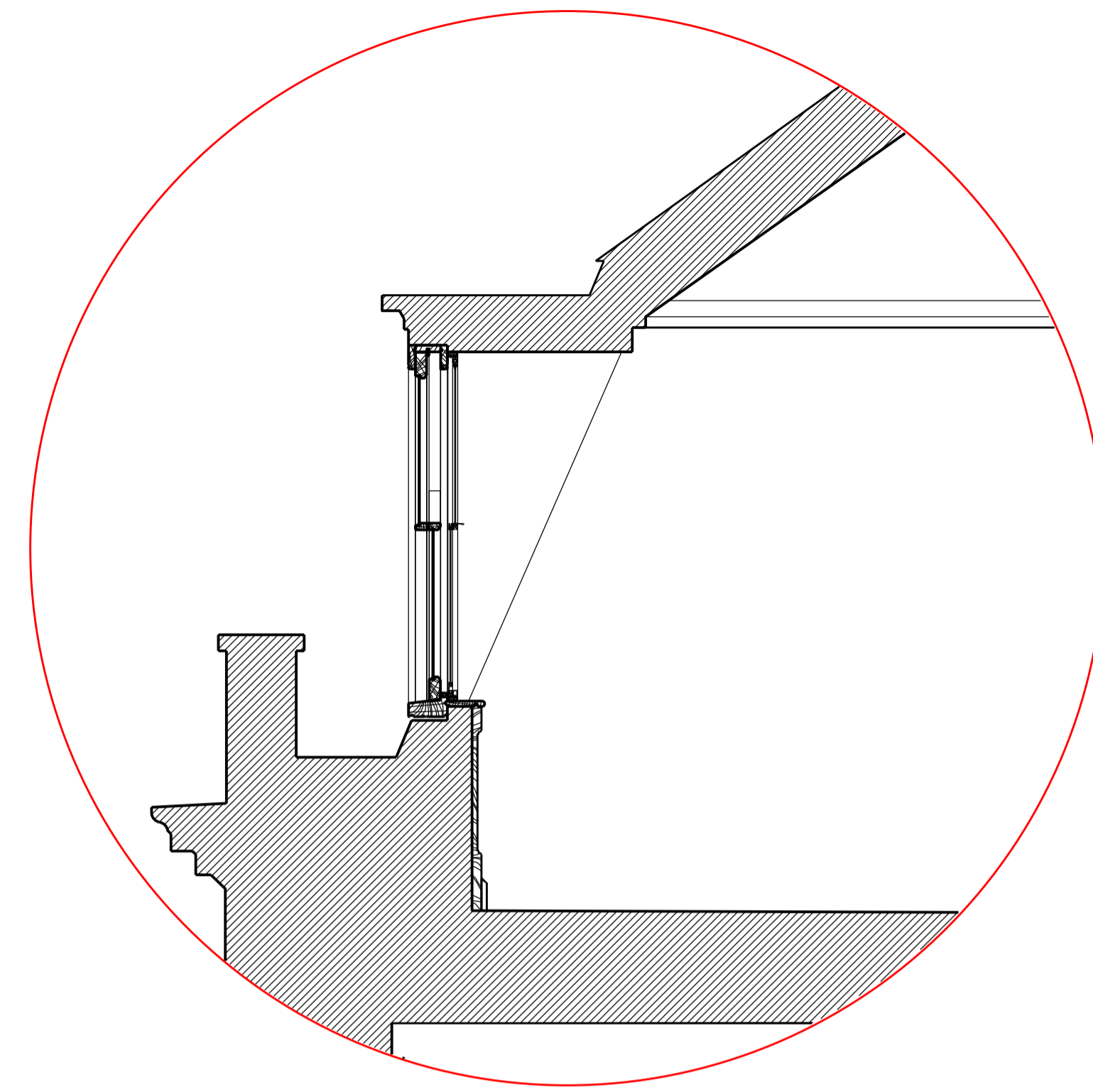

TYPICAL SECTION THROUGH THIRD FLOOR DORMER WINDOW SCALE 1:20

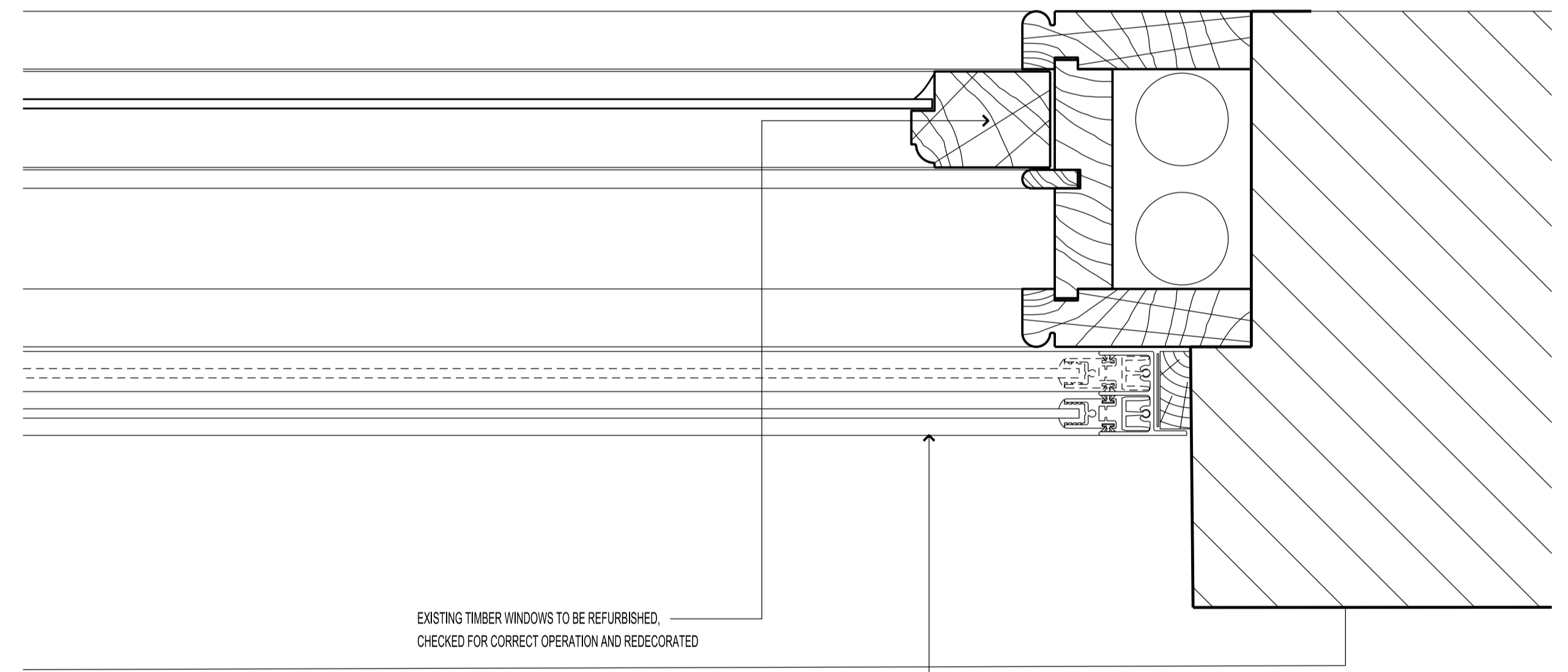

EXISTING TIMBER WINDOWS TO BE REFURBISHED, CHECKED FOR CORRECT OPERATION AND REDECORATED

SECONDARY GLAZING IN ALUMINIUM FRAMED VERTICAL SLIDING UNITS PAINTED WHITE AND FIXED VIA MOULDED HARDWOOD GROUNDS TO EXISTING JOINERY
INDICATIVE SPECIFICATION: SELECTAGLAZE
- SERIES 20 FOR ALL WINDOWS LESS THAN 3000mm HIGH

JAMB DETAIL USING SERIES 20 UNITS AT THIRD FLOOR DORMER

BUILDING DESIGN PARTNERSHIP LTD SHALL HAVE NO RESPONSIBILITY FOR ANY USE MADE OF THIS DOCUMENT OTHER THAN FOR THAT WHICH IT WAS PREPARED AND ISSUED

ALL DIMENSIONS SHOULD BE CHECKED ON SITE.

DO NOT SCALE FROM THIS DRAWING.

ANY DRAWING ERRORS OR DIVERGENCES SHOULD BE BROUGHT TO THE ATTENTION OF BUILDING DESIGN PARTNERSHIP LTD AT THE ADDRESS SHOWN.

REVISION / DESCRIPTION	DRAWN	CHECKED	DATE	REVISION / DESCRIPTION	DRAWN	CHECKED	DATE	REVISION / DESCRIPTION	DRAWN	CHECKED	DATE	REVISION / DESCRIPTION	DRAWN	CHECKED	DATE	REV. PLAN

FIRST ISSUE - LBC APPLICATION MB TL 01.06.2015

CLIENT LOGO

BDP.

16 Brewhouse Yard
Clerkenwell
London, EC1V 4LJ
United Kingdom

T +44 (0)20 7812 8000
F +44 (0)20 7812 8399
www.bdp.com

PROJECT TITLE
42 BEDFORD SQUARE

PROJECT NUMBER
P2005698

DRAWING TITLE
**SECONDARY GLAZING DETAILS
CILL, HEAD AND JAMB CONDITIONS
DORMER WINDOW CONDITION**

SCALE @ A1
1:2

DATE
05.2015

DRAWING NO.
P04_(31)AD015

REVISION
-