

1. DO NOT SCALE THIS DRAWING. DIMENSIONS SHOWN IN THIS DRAWING ARE TO BE TAKEN FROM THE DRAWING. DIMENSIONS ARE TO BE TAKEN FROM THE DRAWING UNLESS OTHERWISE SPECIFIED.
2. THIS DRAWING IS TO BE READ IN CONJUNCTION WITH ALL OTHER DRAWINGS, SPECIFICATIONS AND SPECIFICATIONS.
3. ALL DIMENSIONS AND LEVELS ARE TO BE CHECKED ON SITE. PREPARE ANY WORKING DRAWINGS OR COMMENCE ON SITE.
4. THE CONTRACTOR MUST ENSURE AND WILL BE HELD RESPONSIBLE FOR THE OVERALL STABILITY OF THE BUILDING/STRUCTURE/EXCAVATION AT ALL STAGES OF THE WORK.
5. ALL WORK BY THE CONTRACTOR MUST BE CARRIED OUT IN SUCH A WAY THAT ALL REQUIREMENTS UNDER THE HEALTH AND SAFETY AT WORK ACT ARE MET.
6. ALL WORK IS TO BE CARRIED OUT IN COMPLIANCE WITH THE REQUIREMENTS OF THE RELEVANT STATUTES, REGULATIONS, AUTHORITIES AND REGULATIONS.
7. REFER TO SPECIFICATIONS FOR FURTHER NOTES

GENERAL KEY :

	EXISTING MASONRY WALLS
	NEW MASONRY WALLS
	DEMOLITION
	STRUCTURAL WALLS UNDER
	MASS CONCRETE FOUNDATIONS
	NEW REINFORCED CONCRETE READY-MIX RC30/35
	SPAN OF EXISTING FLOOR
	SPAN OF NEW TIMBER/ CONCRETE SEE NOTES
	NEW STEEL BEAMS
	NEW TIMBER BEAMS
	TIMBER STUD PARTITIONS UNLESS NOTED OTHERWISE, DOUBLE UP JOISTS / PROVIDE SOLID NOGGING UNDER
	12MM RC SPEARTING FIXED WITH PERIMETER/250 INTERNALLY
	SEPARATE STRAPS AS PER SPEC AND DETAILS
	SOLID MASONRY WALLS TO MATCH EXISTING, TOOTHED IN TO THE EXISTING WALL AND DRY PACK OVER

READ IN CONJUNCTION WITH SPECIFICATION NOTES DRAWING SH-001

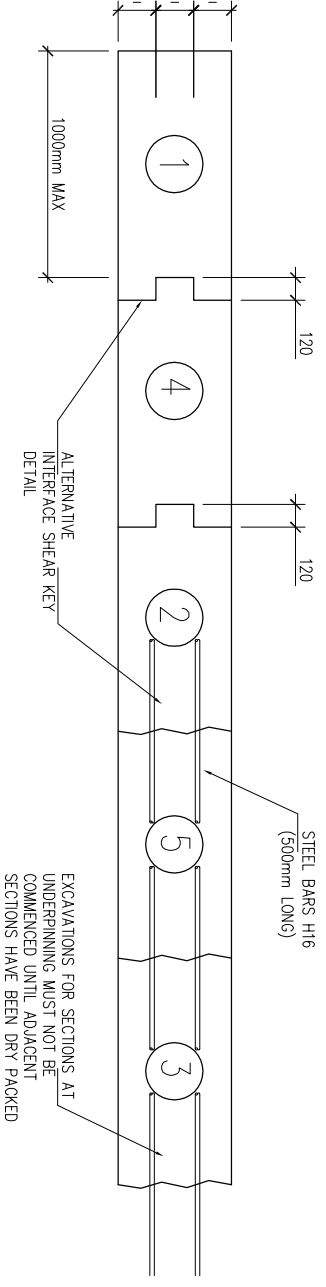
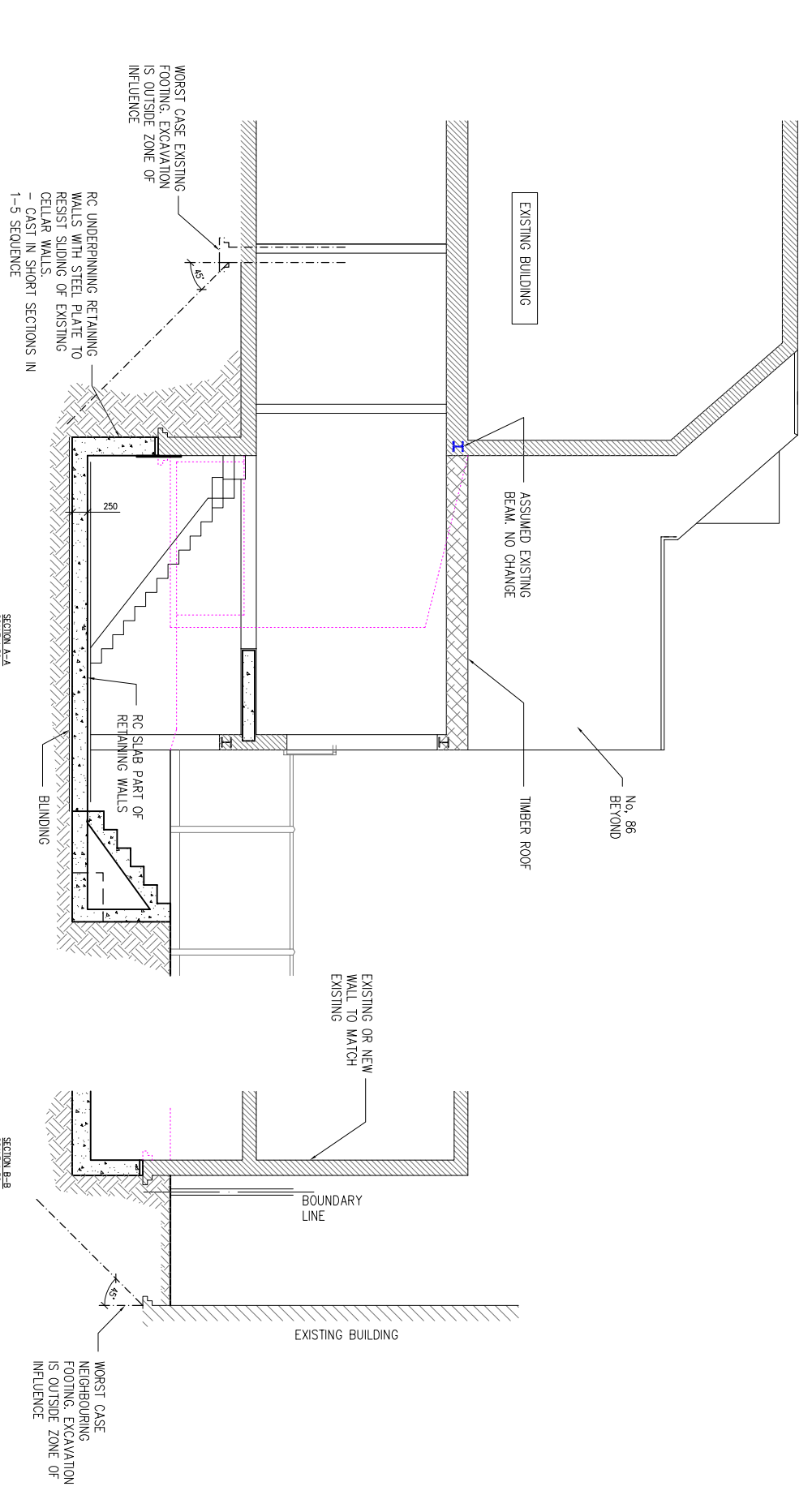

TYPICAL CONCRETE UNDERPINNING PLAN DETAIL

Rev	Date	Issued For
B1	24/06/2015	ISSUED FOR PLANNING

AXIOM STRUCTURES LIMITED
 M: 07736098377, T: 20 3837 2751
 email: office@axiom-structures.co.uk

SITE
 84A WEST END LANE
 LONDON NW6 2LX

PROPOSED PLANS

DATE	SCALE
JUNE '15	1:50 AT A1 1:100 AT A3
DRAWN	DRAWING STATUS
KL / AP	PLANNING
DRAWING NO:	REV
15093/25/200	11

THIS DRAWING HAS BEEN PREPARED TO ASSIST PLANNING APPLICATION AND SHOULD NOT BE READ AS FOR CONSTRUCTION.