

orsini**brewin**

Planning Drawings

36C Gloucester Crescent

Camden

London

NW1 7DL

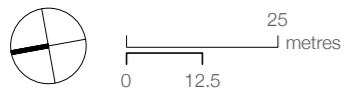

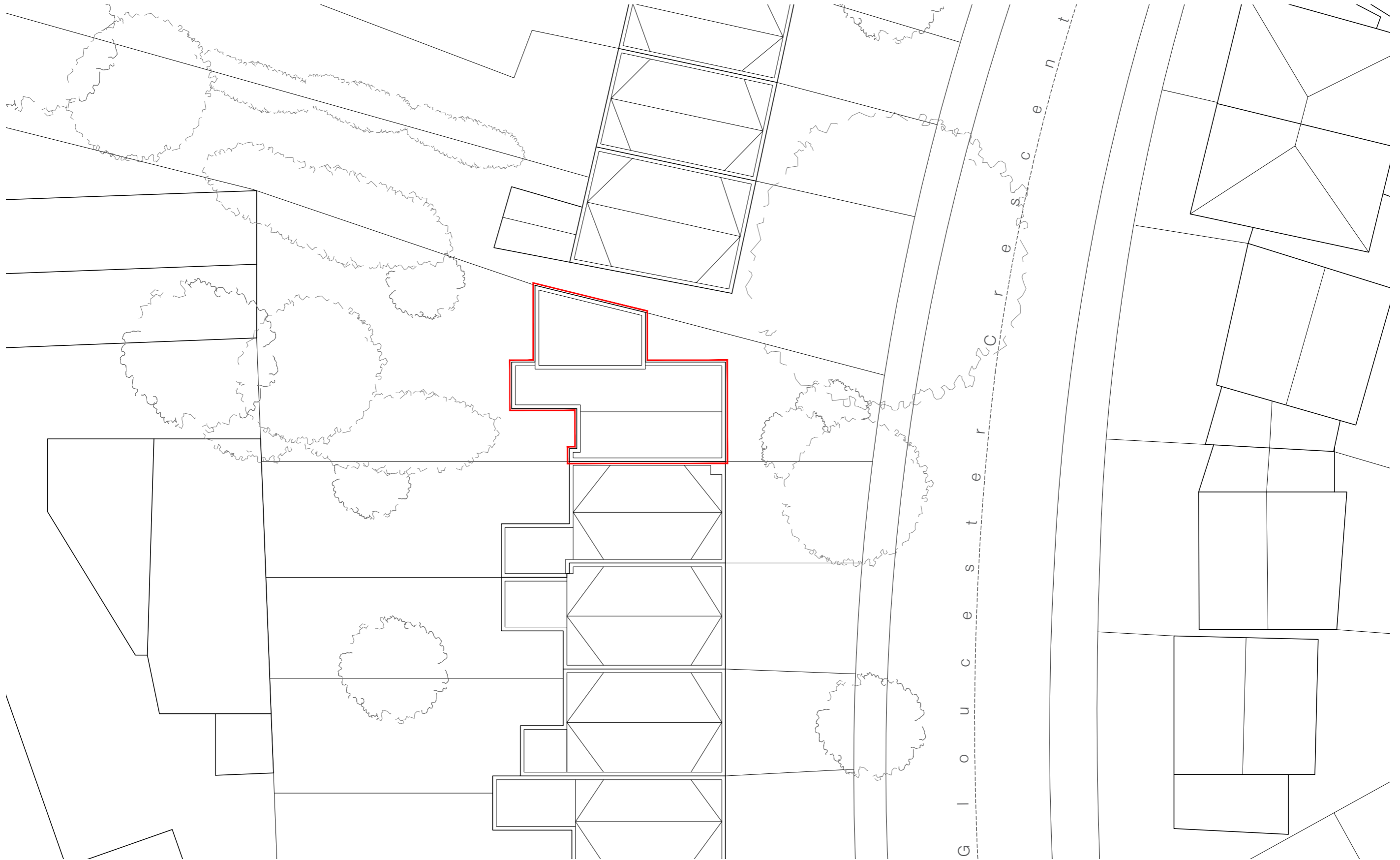

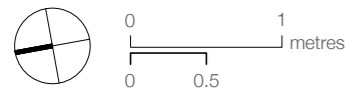
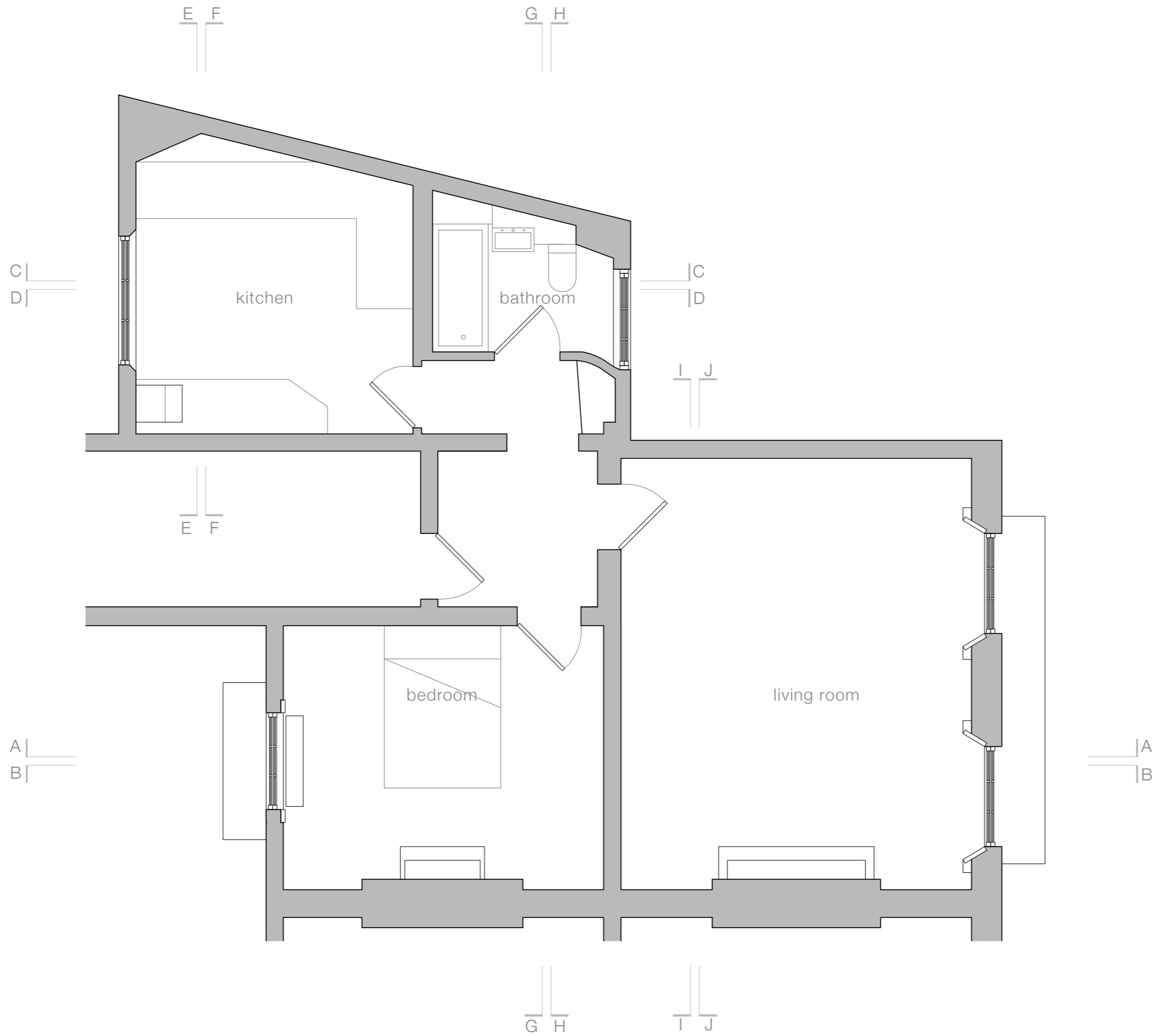

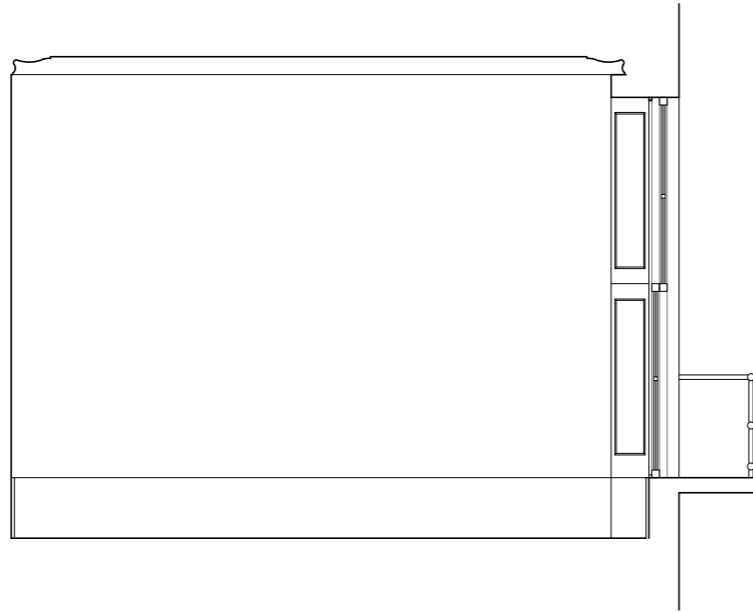

Section AA

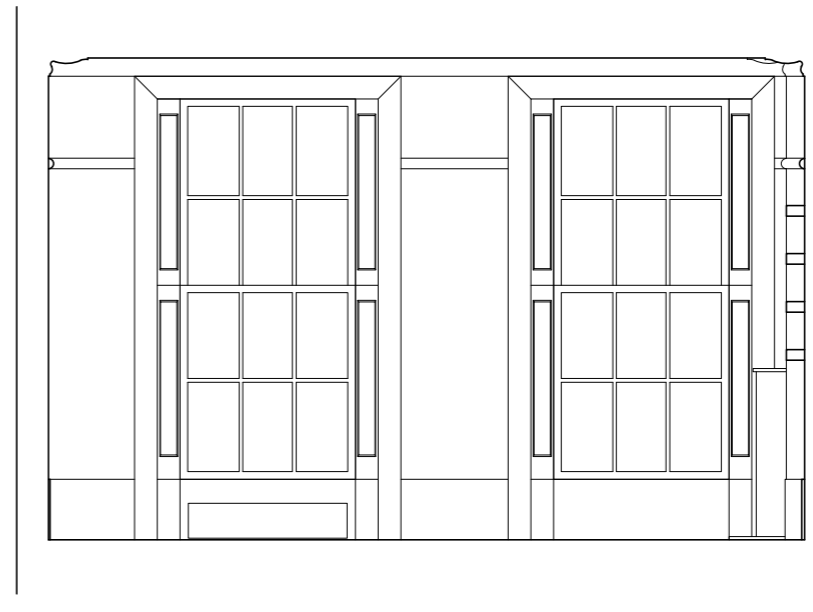

Section JJ

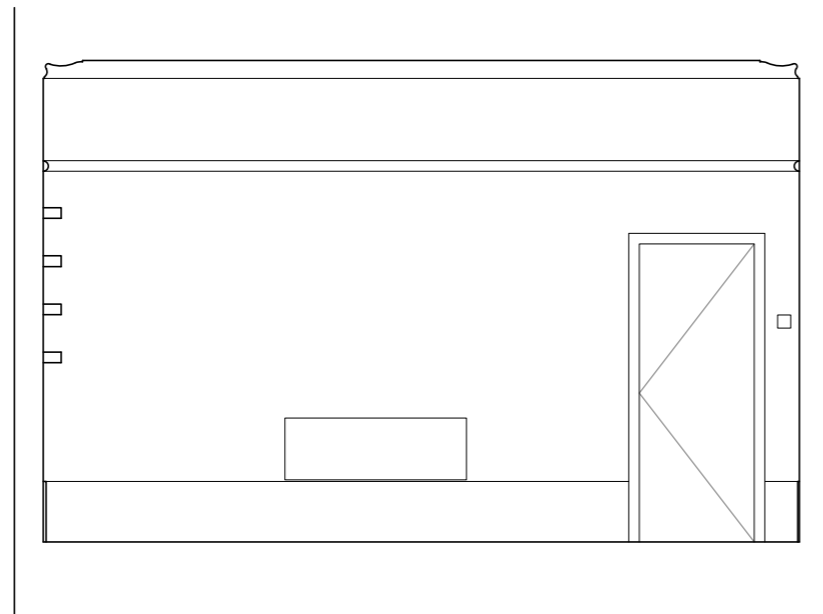

Section II

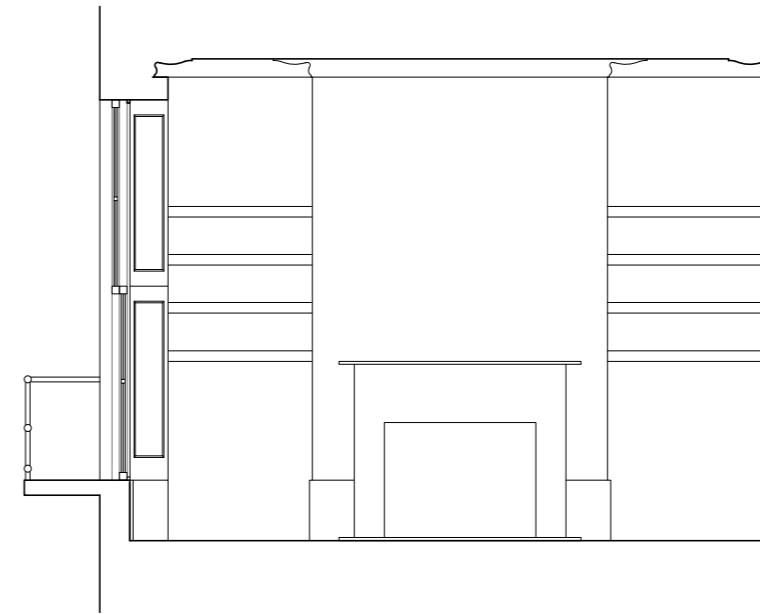

Section BB

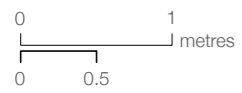

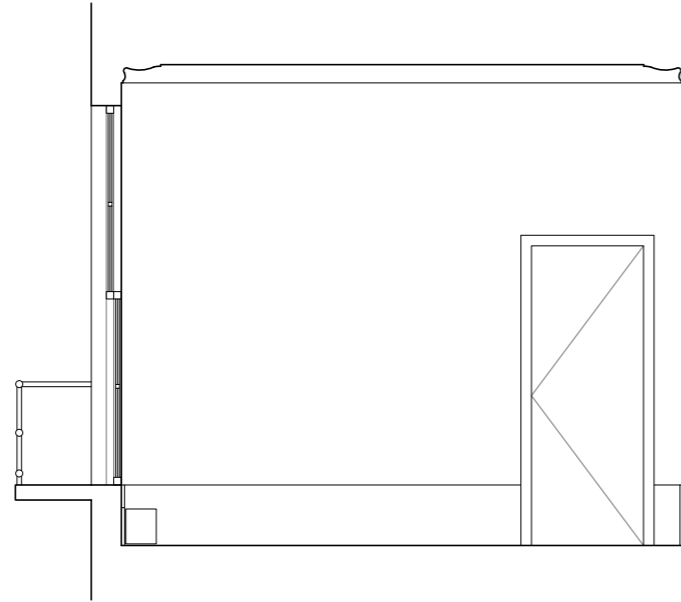

Section AA

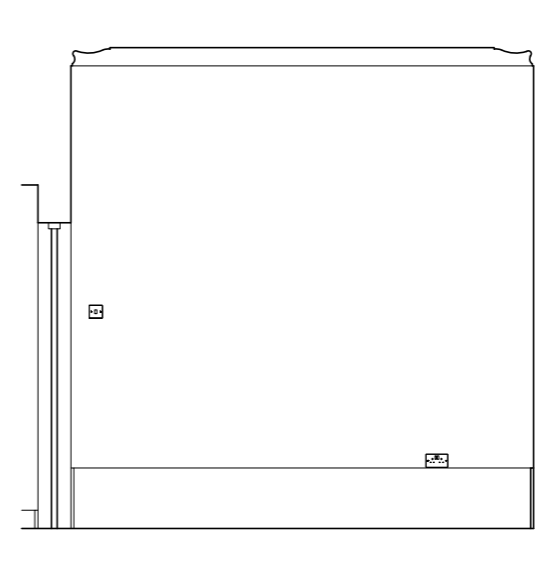

Section HH

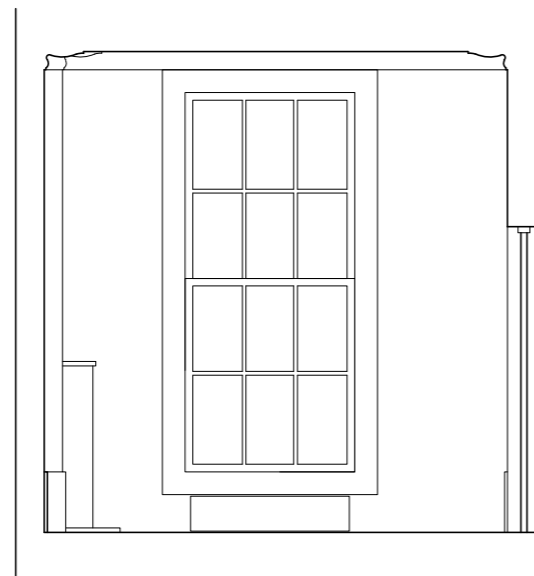

Section GG

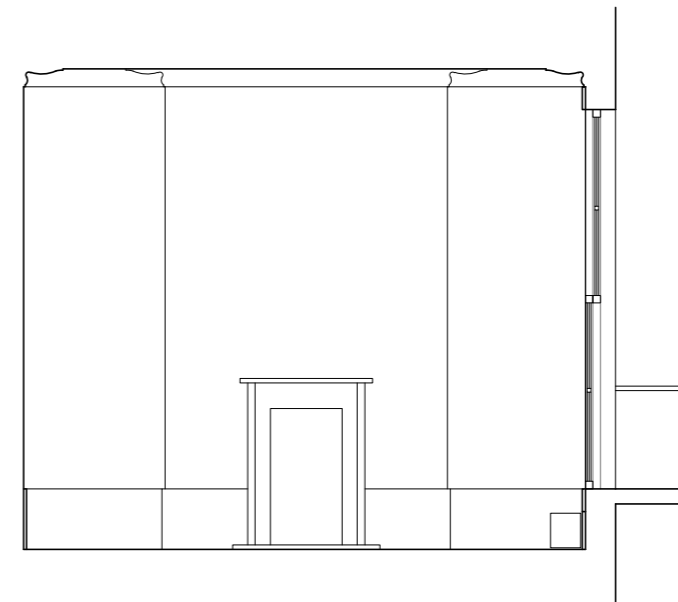

Section BB

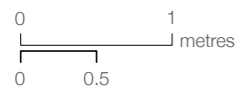

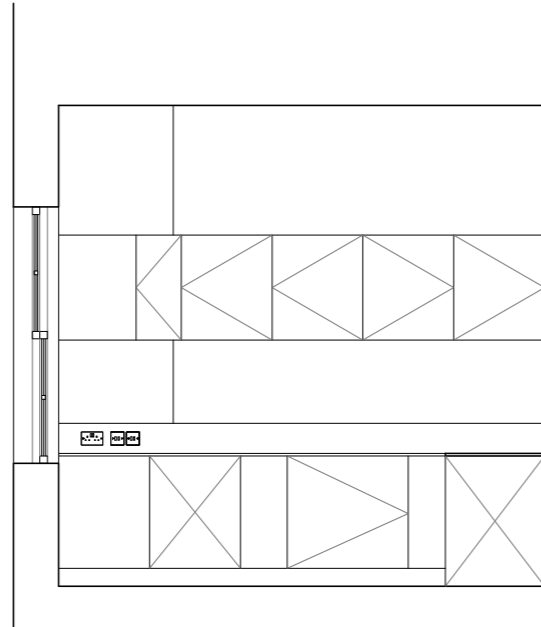

Section CC

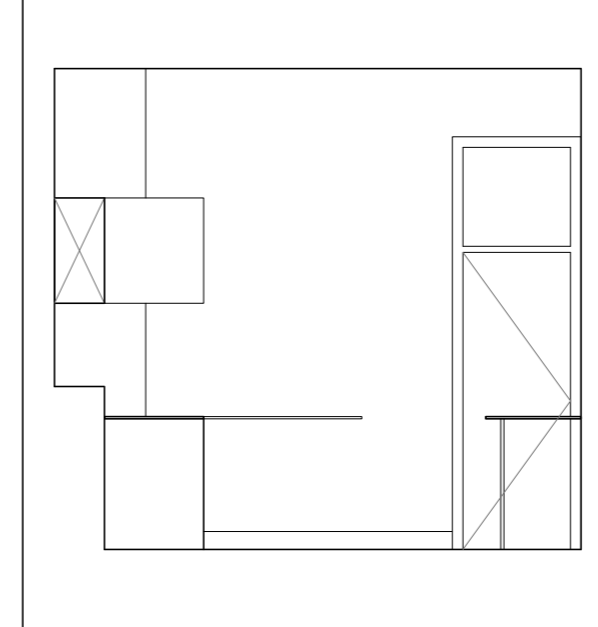

Section FF

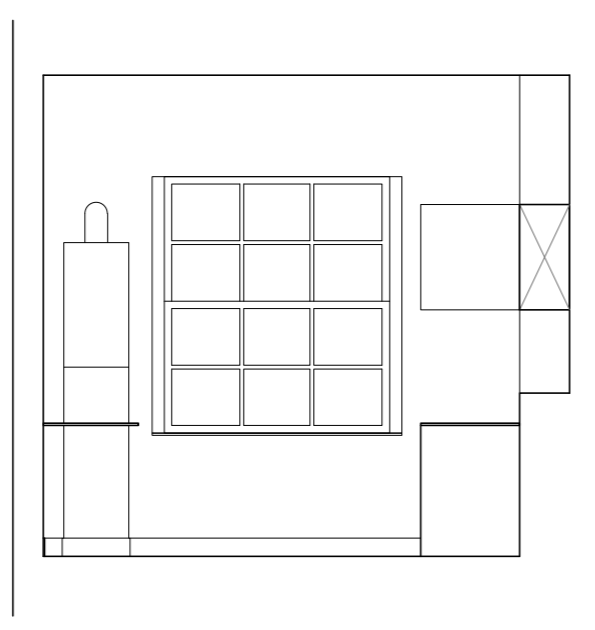

Section EE

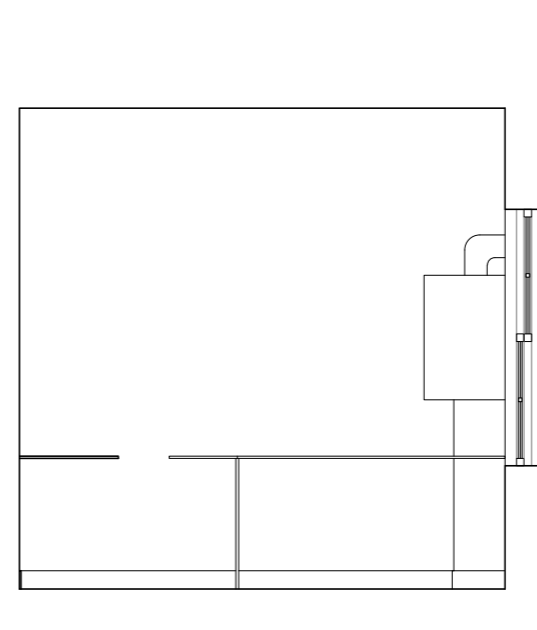

Section DD

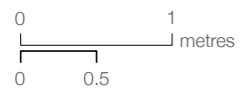

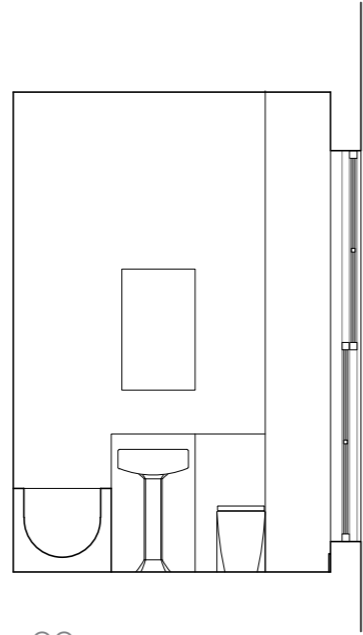

Section CC

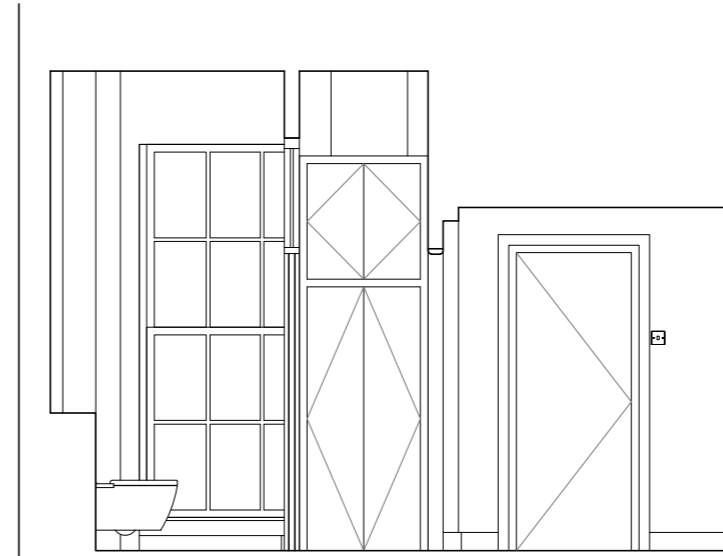

Section HH

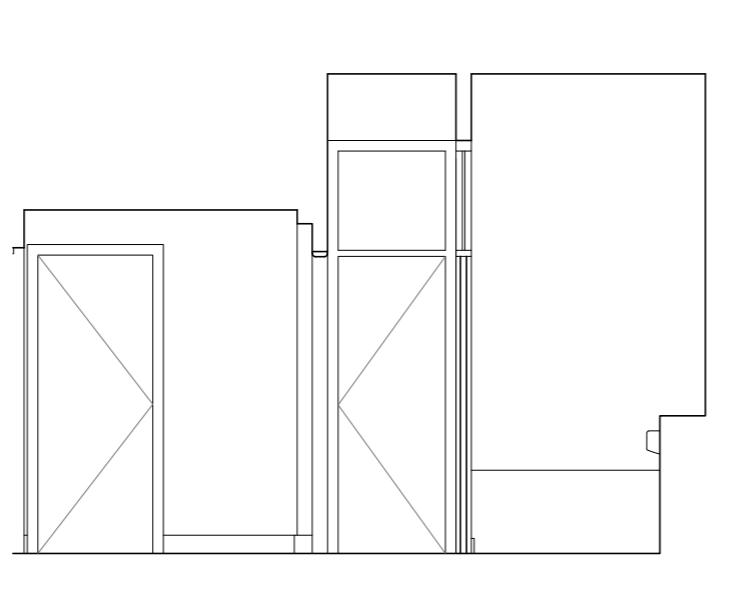

Section GG

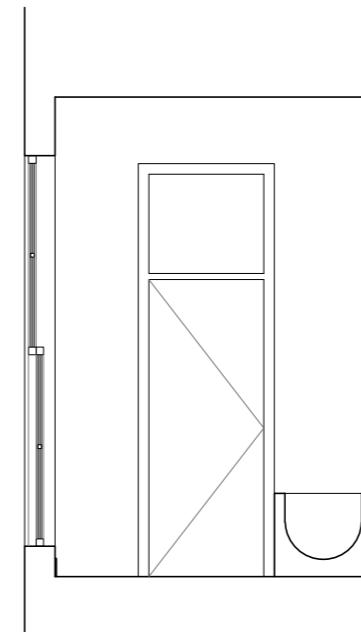

Section DD

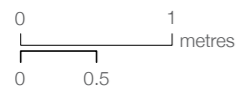

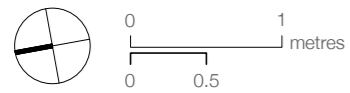
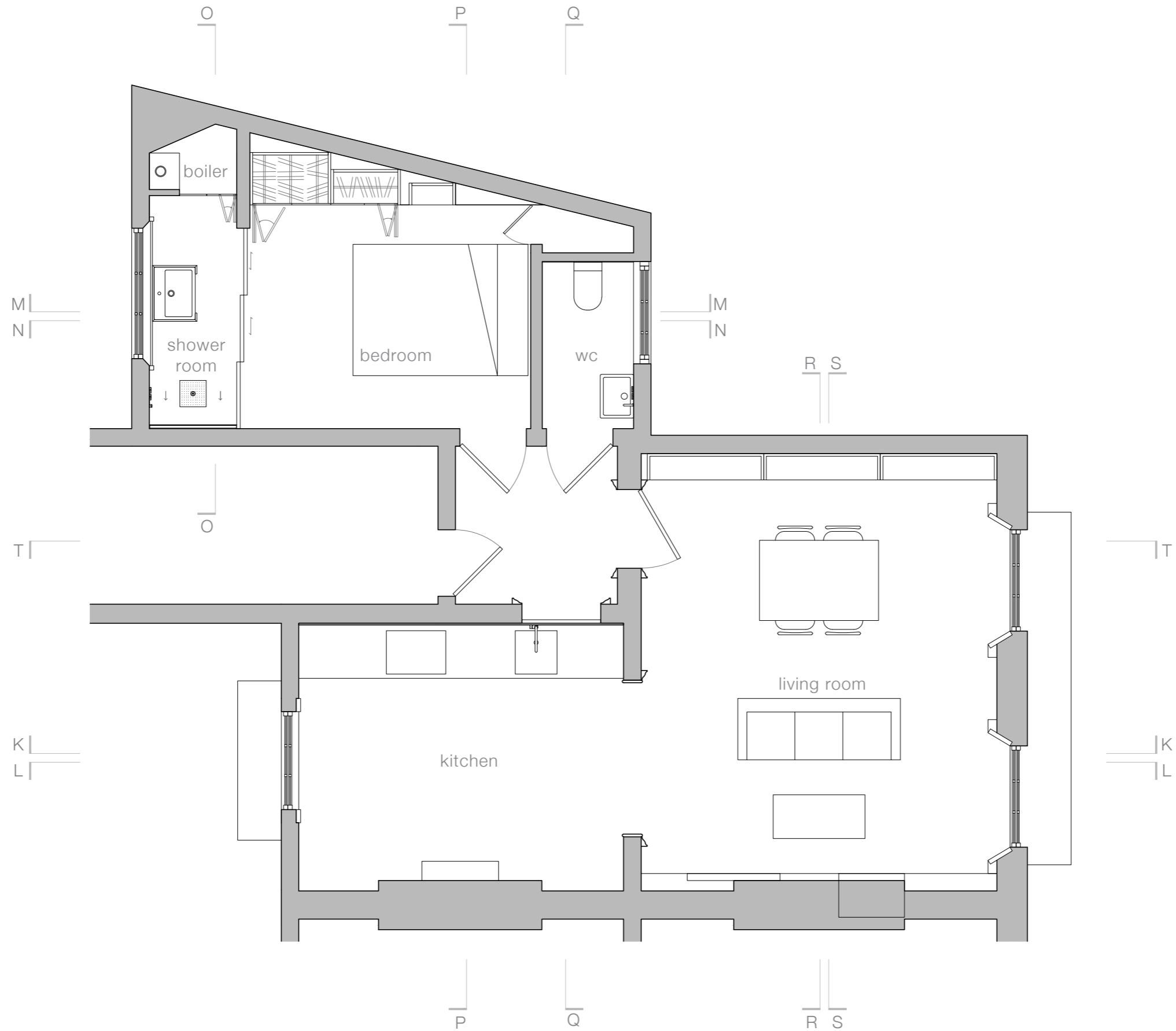

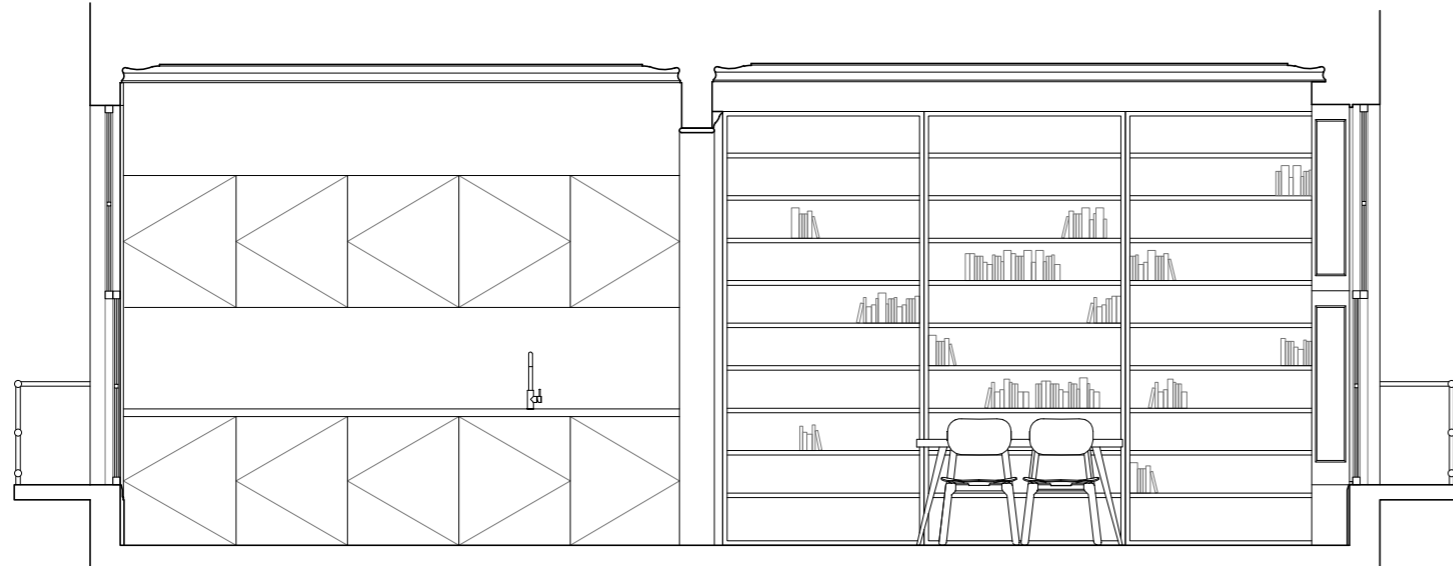

Section KK

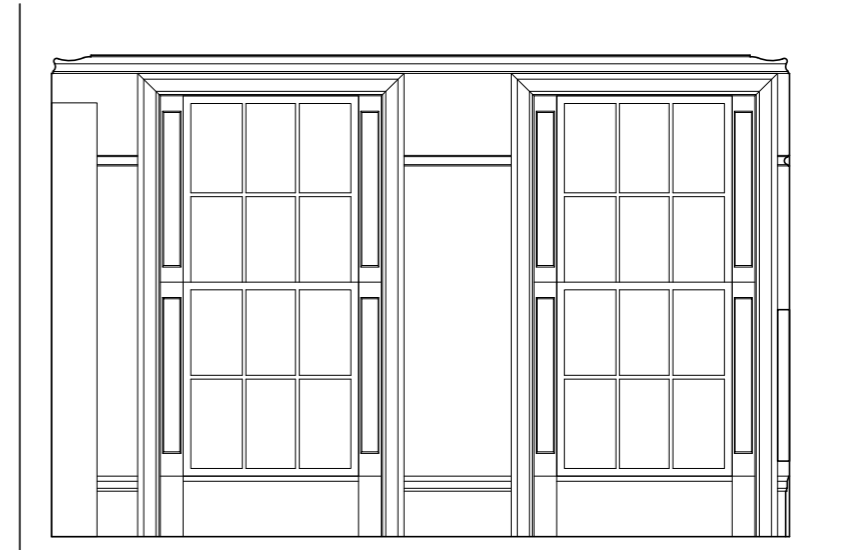

Section SS



Section PP

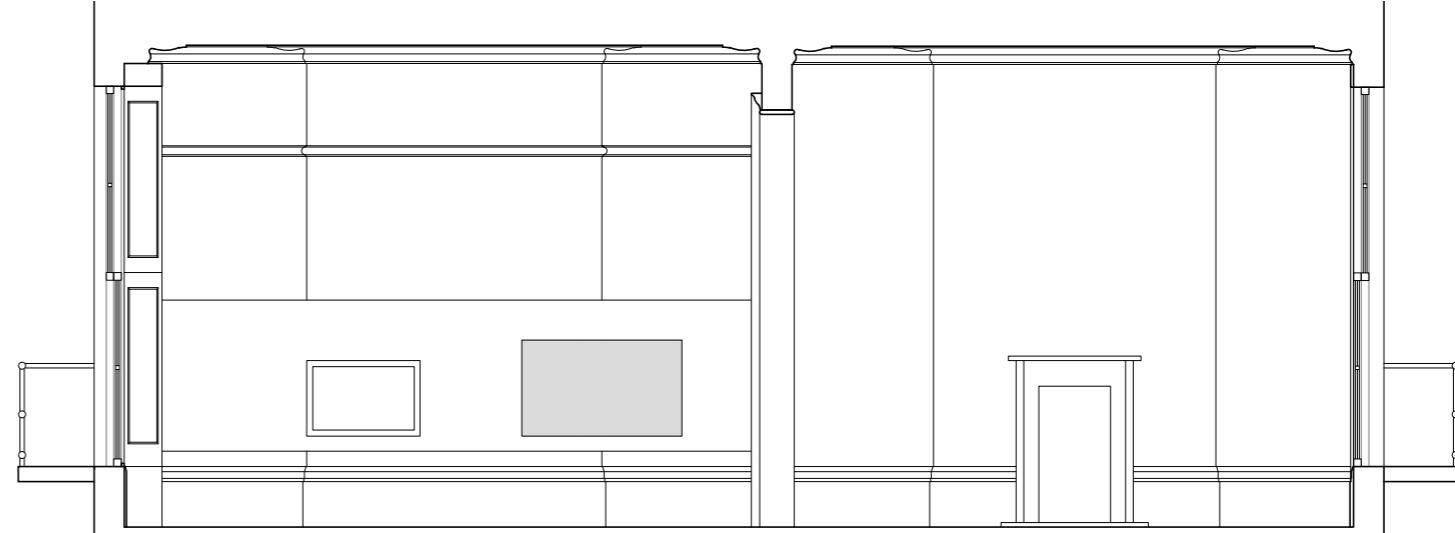

Section LL



Section RR



Section QQ

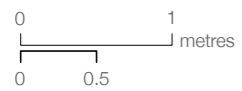

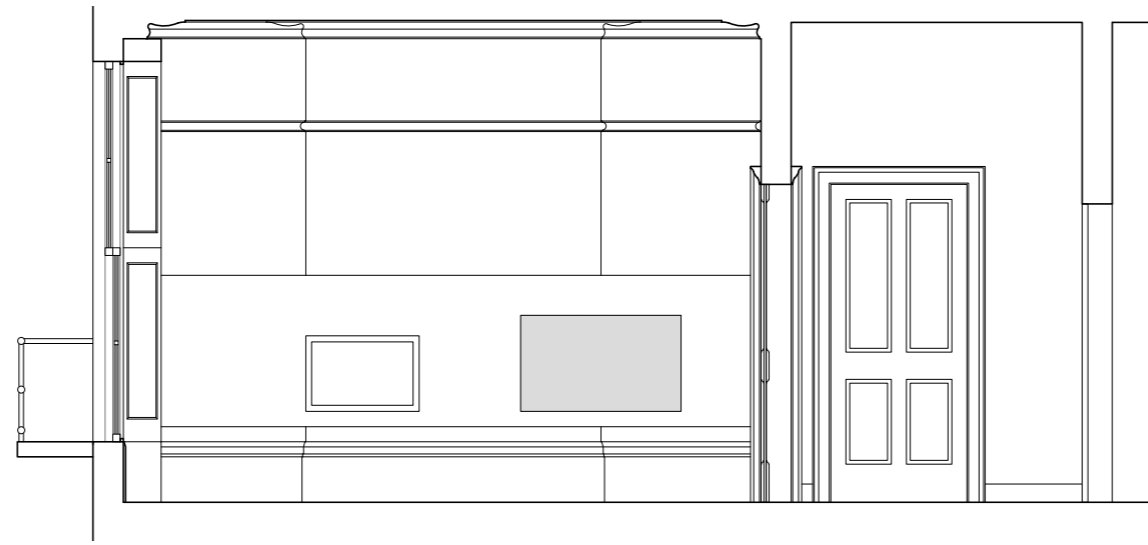

Section TT

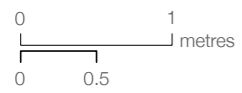

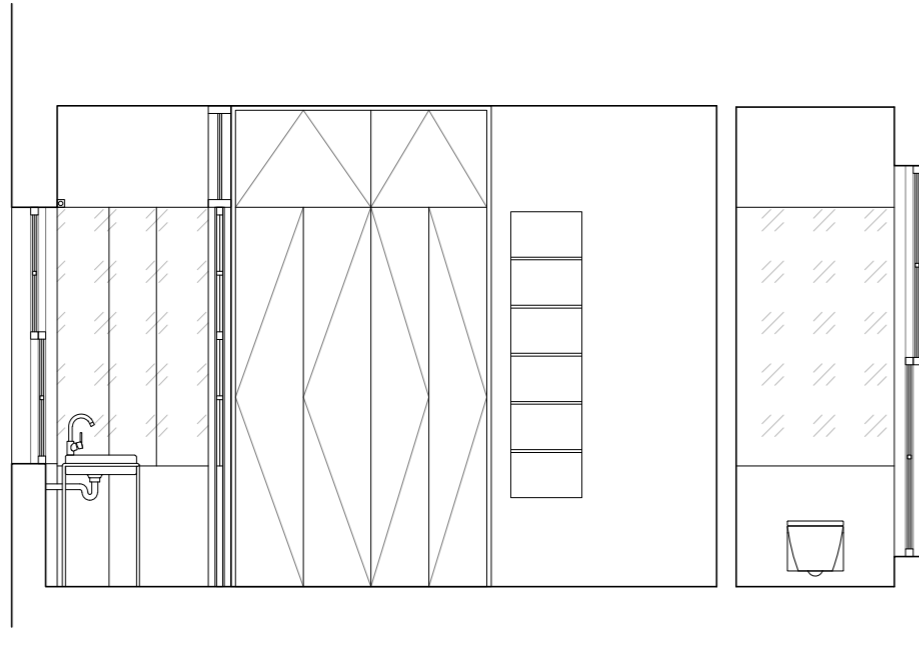

Section MM

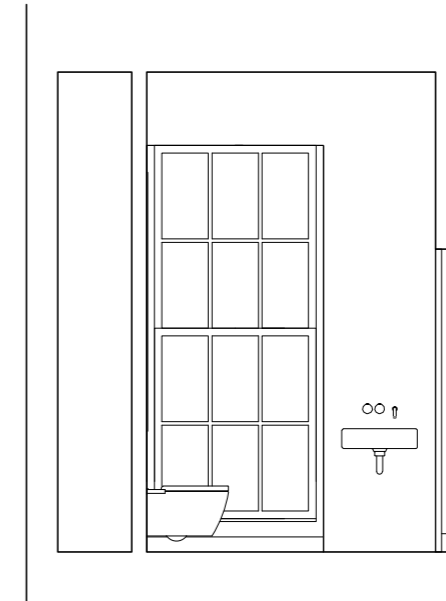

Section QQ

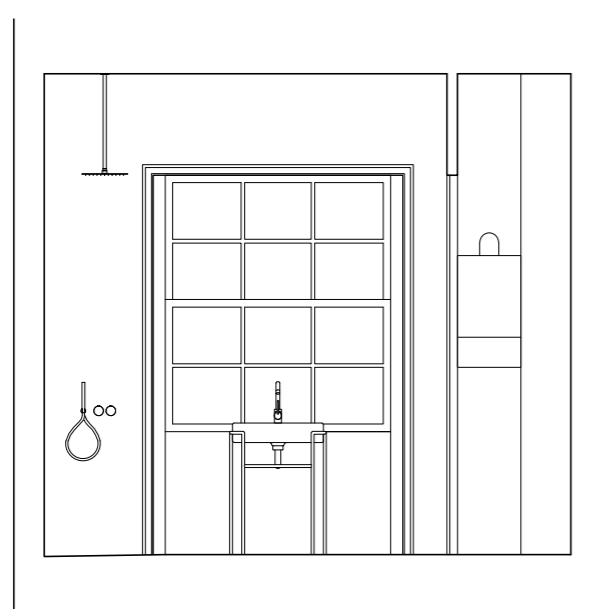

Section OO

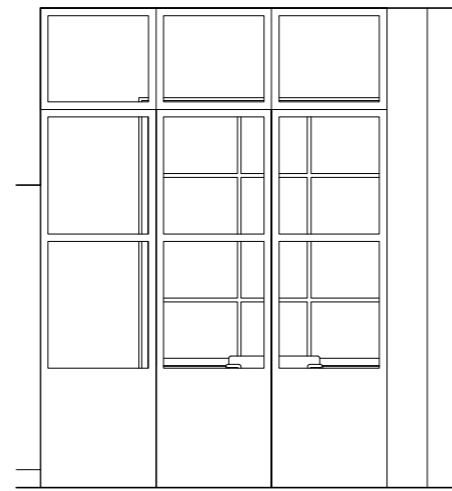

Section PP

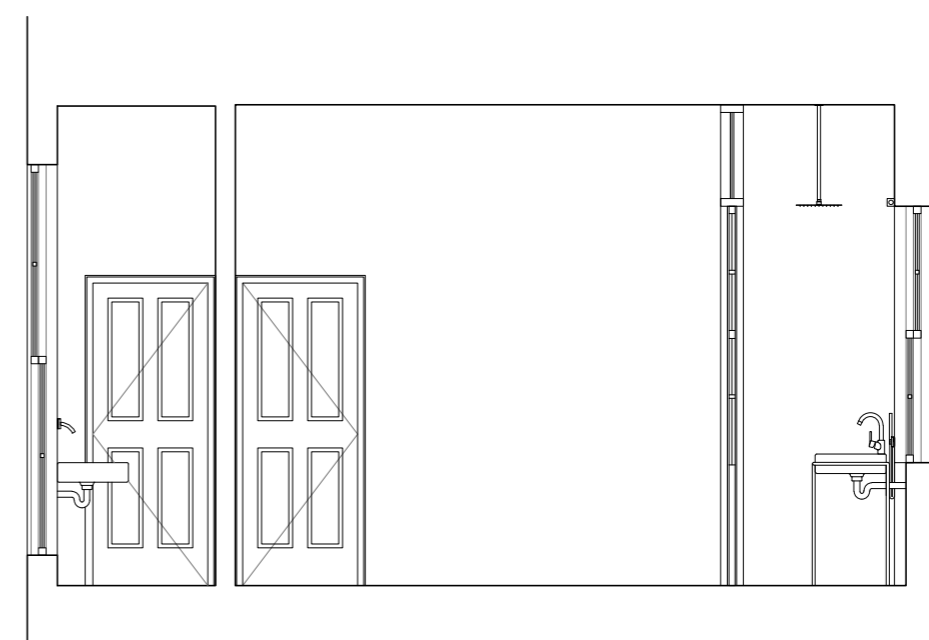

Section NN

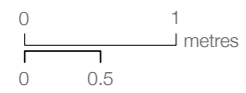

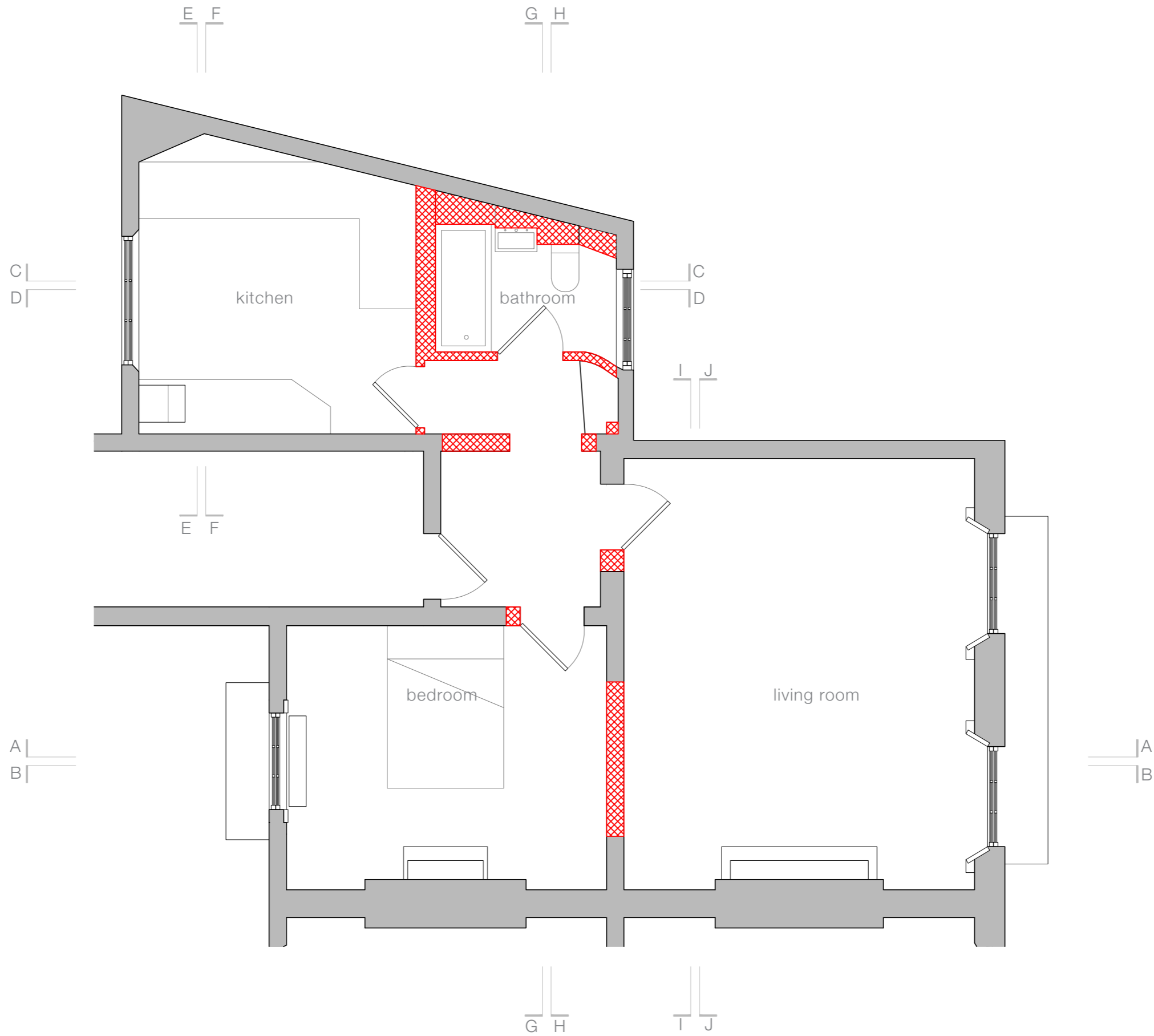

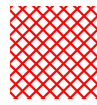
 areas to be demolished

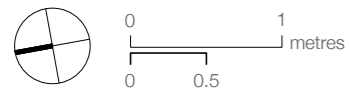

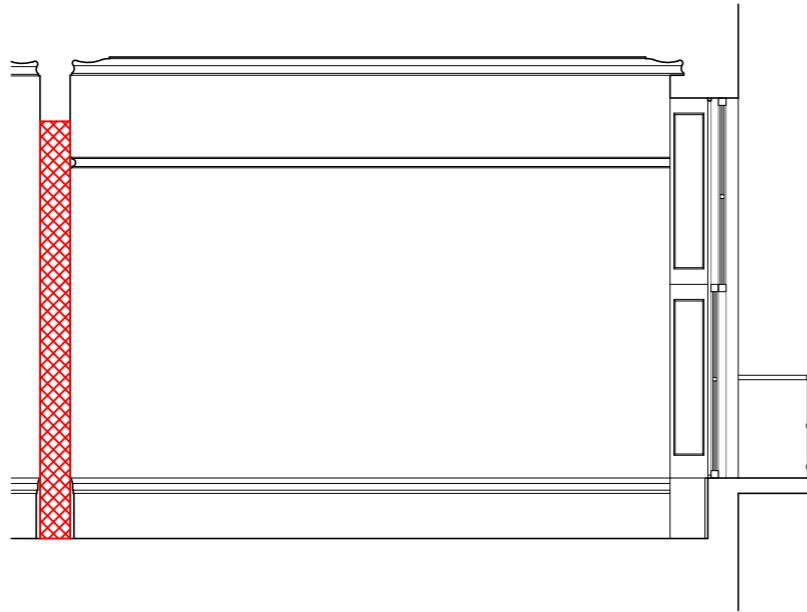

Section AA

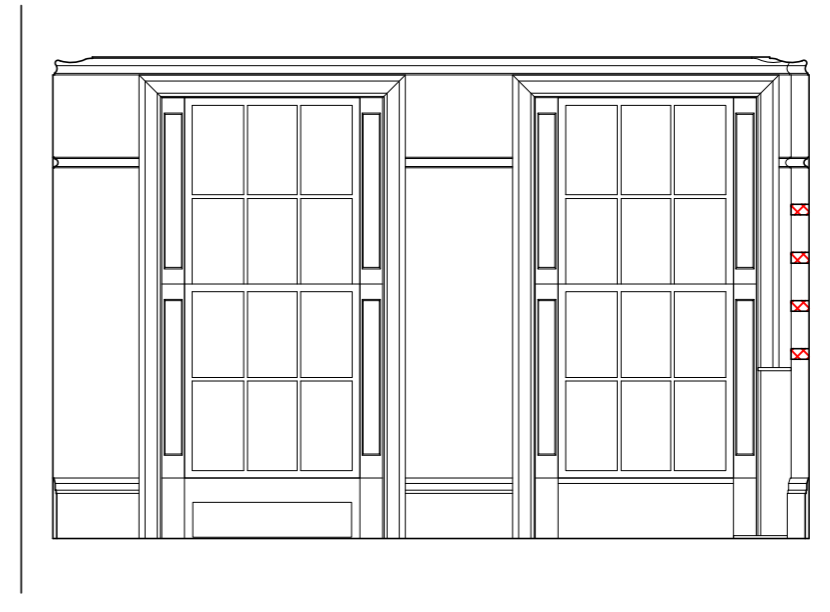

Section JJ

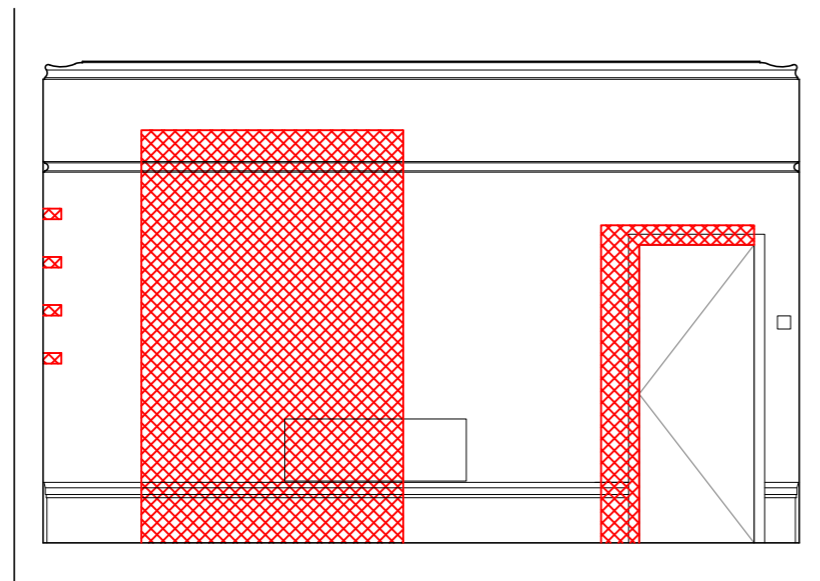

Section II

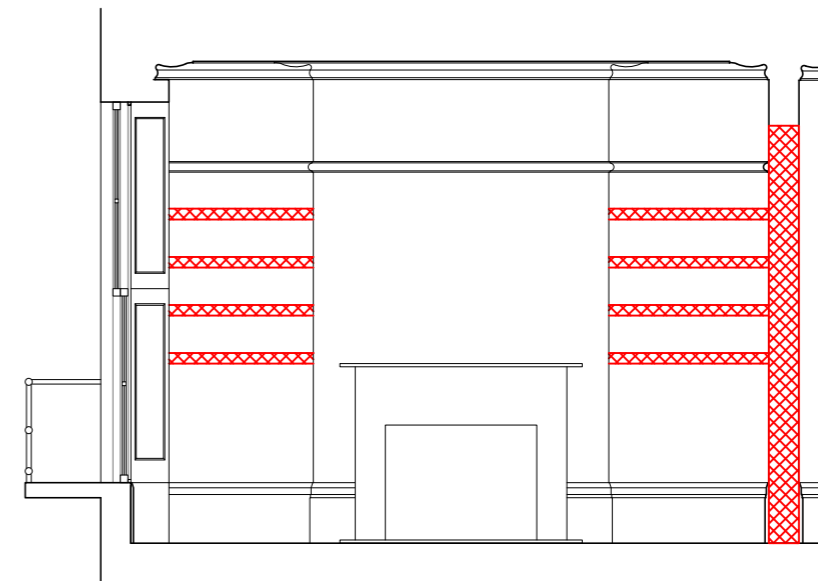

Section BB

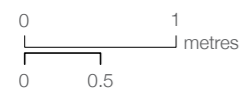
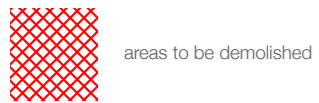

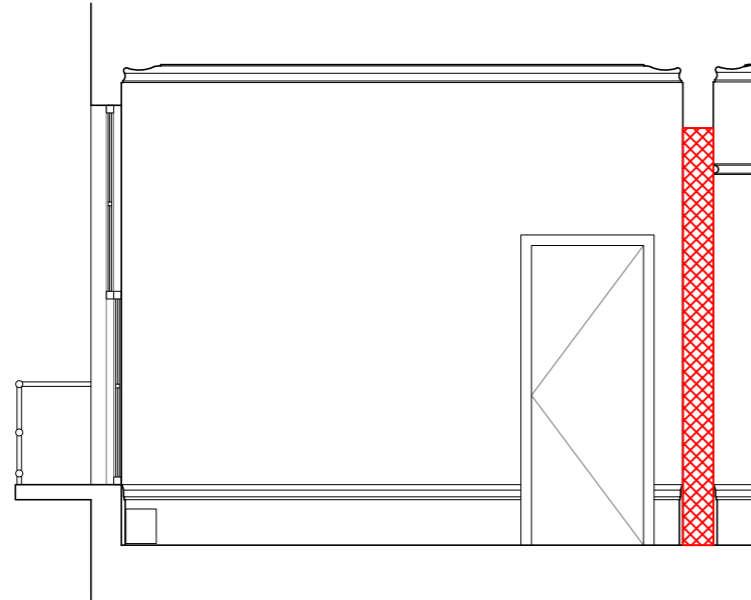

Section AA

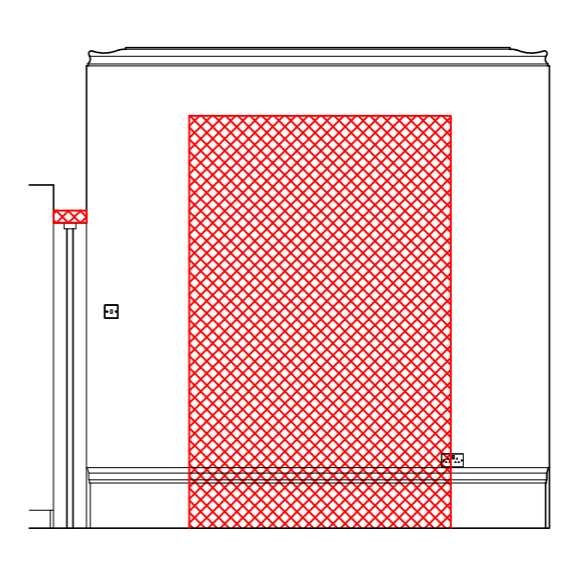

Section HH

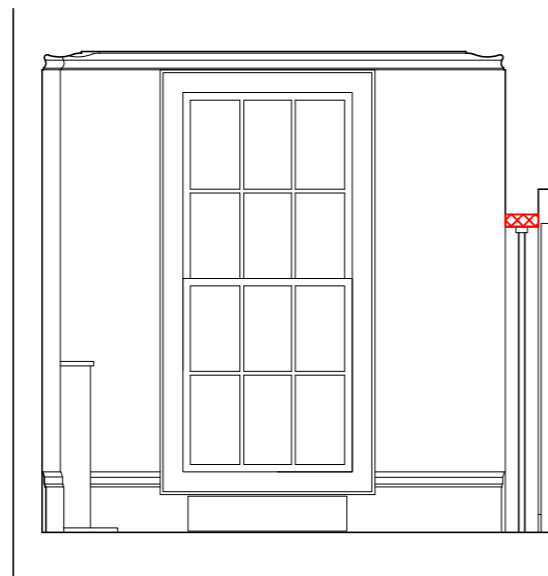

Section GG

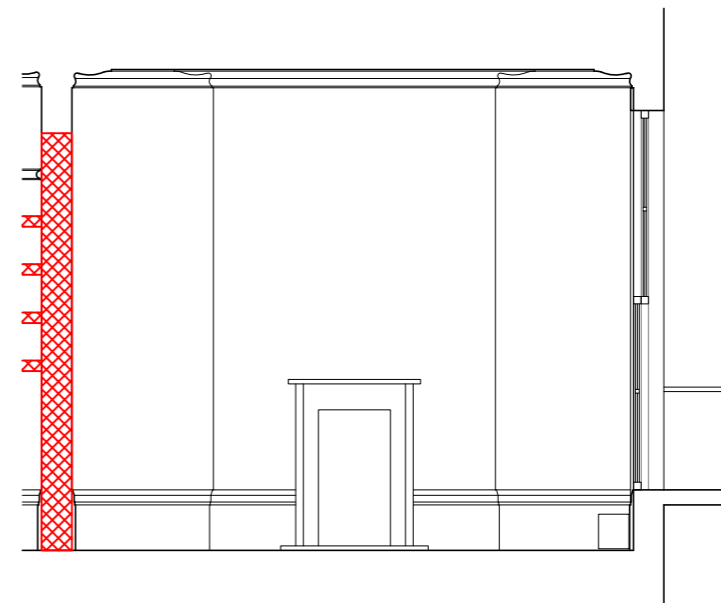

Section BB

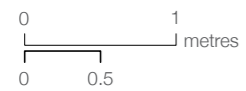
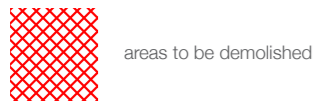

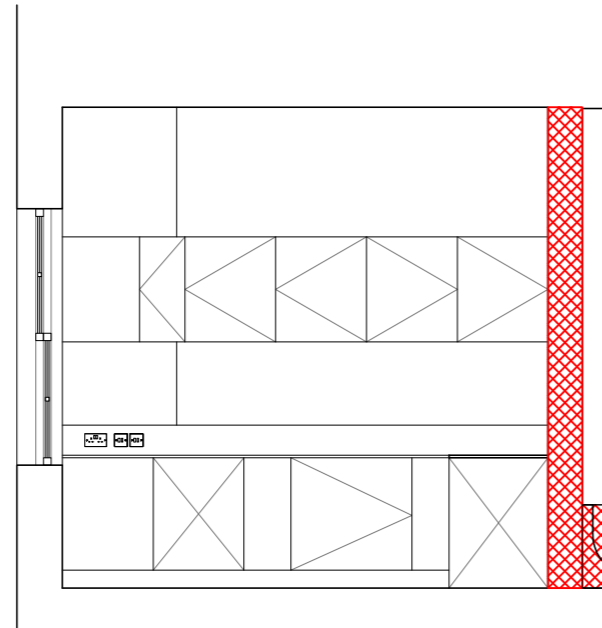

Section CC

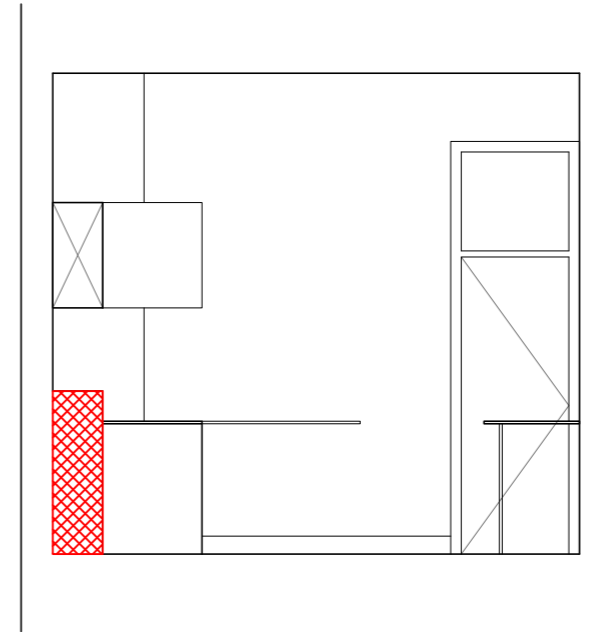

Section FF

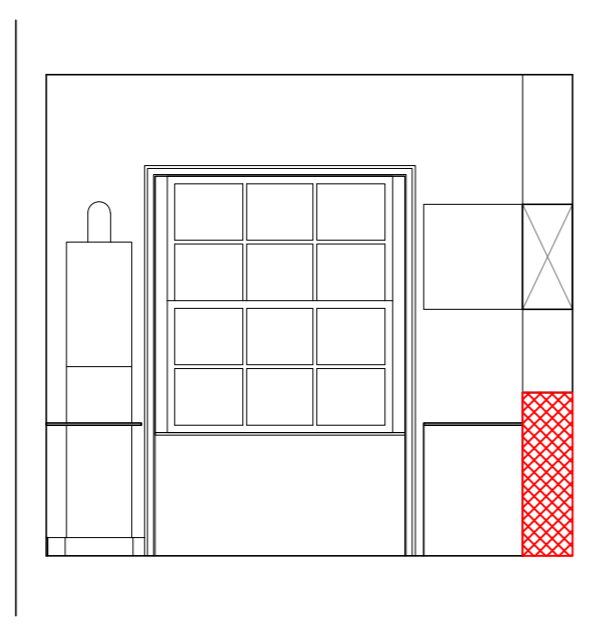

Section EE

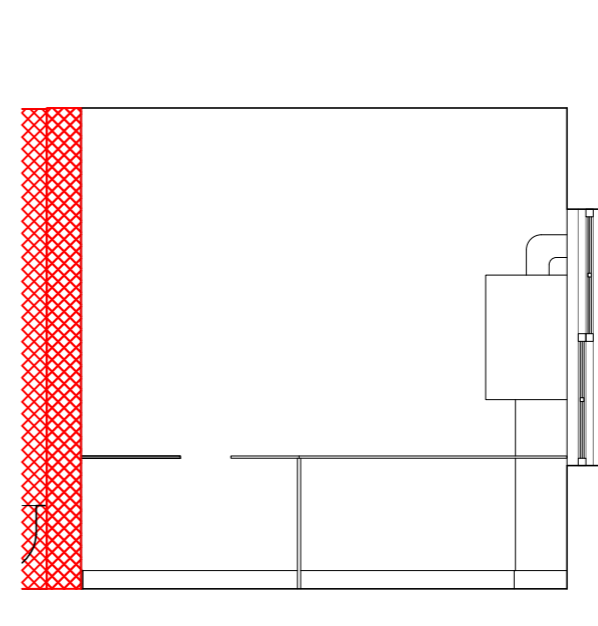

Section DD

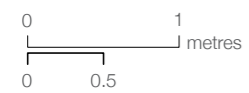
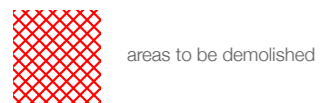

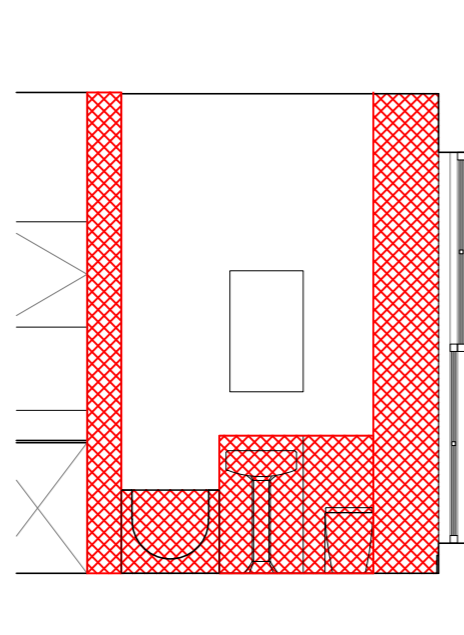

Section CC

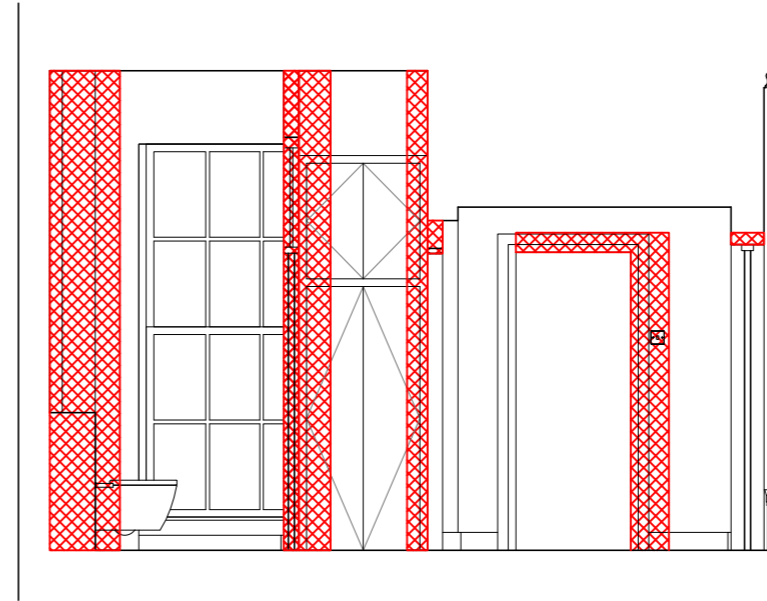

Section HH

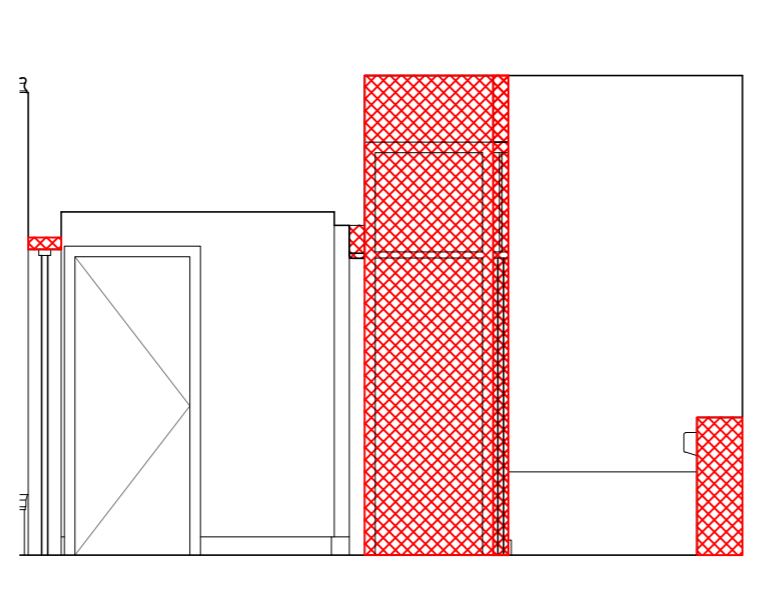

Section GG

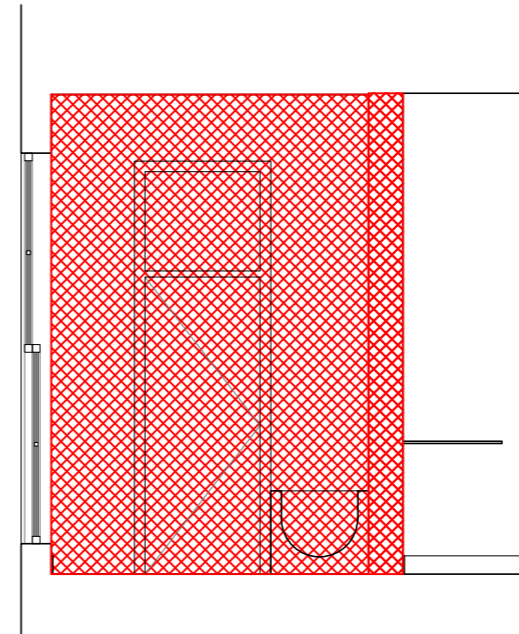

Section DD

