

PCA

POLYMER COMPOSITE ASIA

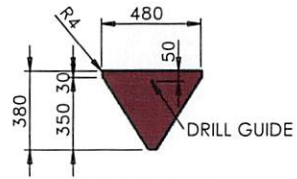

SECTION R-R
SCALE 1 : 25

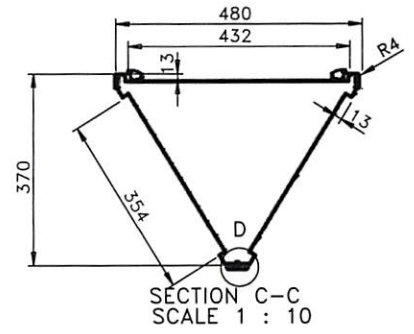
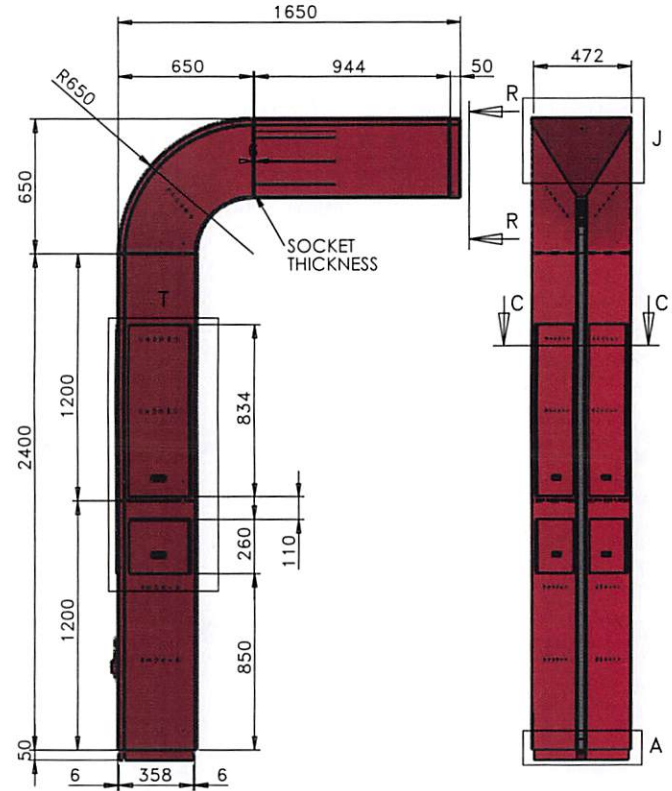
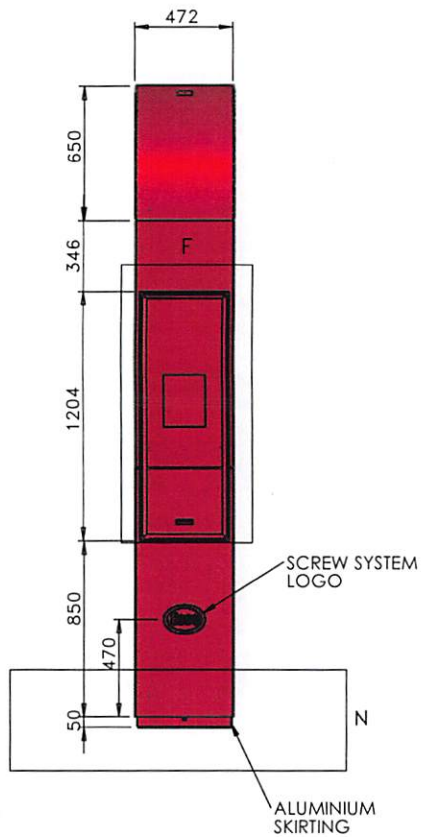
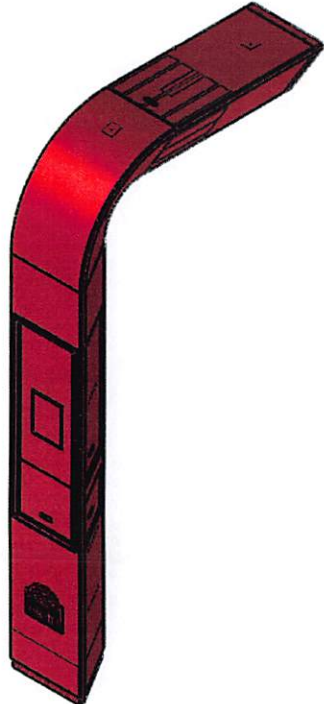
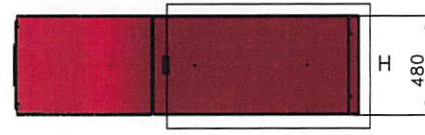

SECTION C-C
SCALE 1 : 10

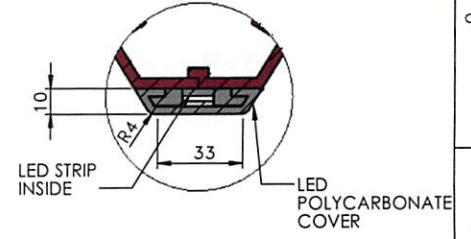

DETAIL D
SCALE 1 : 2

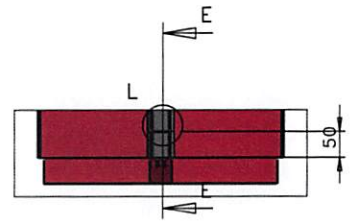

DETAIL A
SCALE 1 : 10

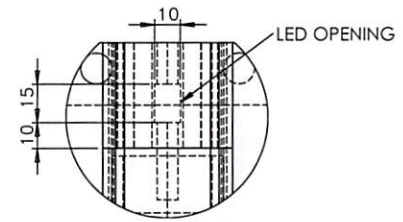

DETAIL L
SCALE 1 : 2

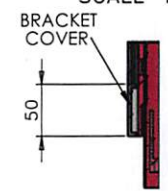

SECTION E-E
SCALE 1 : 5

PRODUCT : WAVE SPREADER

CUSTOMER : EXXON MOBIL

DRAWING NO. : EXX-PMR14-WV-001

APPROVED BY : *Tyork*