

Suitable for private houses, condominium and for retrofitting of old buildings. For permanent use only!
Horizontal even platforms.

Platform load max. 2600 kg (wheel load max. 650 kg).

The systems are designed for snow load zone II with up to 0.75 kN/m² in accordance to DIN 1055-5.

■ Parklift 461 · 2600 kg

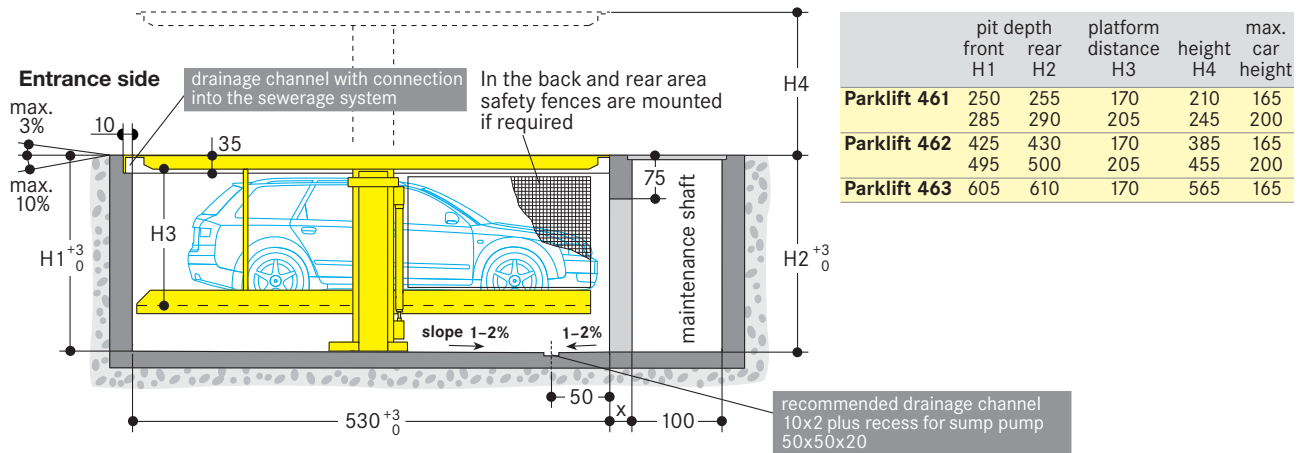

■ Parklift 462 · 2600 kg

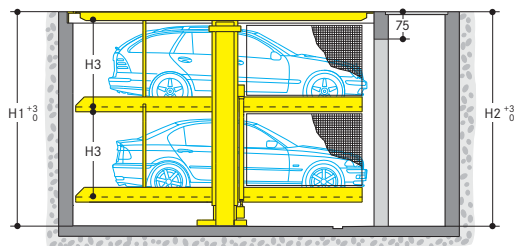

■ Parklift 463 · 2600 kg

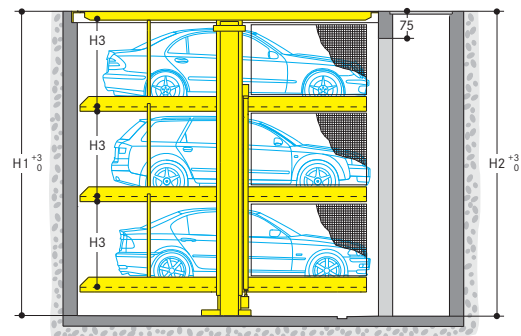

■ Clearance profile (car/station wagon)

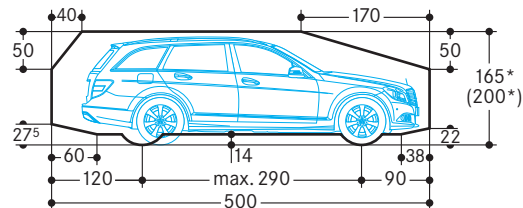

*The total car height includes roof rail and antenna fixture and must not exceed the mentioned max. height dimension.

■ Notes

1. Clear platform width of 250 cm for car widths of 190 cm (see width dimensions stated on page 2). For large touring sedans we recommend a clear platform width of at least 260–270 cm for single and 520–540 cm for double systems.
2. The upper platform is a welded construction (manufactured acc. to EN ISO 13920 with the tolerance class C). Finishes are available at the customers request, for example sand bedding/pavement slabs, sand bedding/pebbles, topsoil/lawn a.s.o. Please contact Wöhr for details of maximum allowed loadings.
3. When lowered, the upper platform is even to floor level and can be driven over by cars (max. weight 2600 kg, wheel load max. 650 kg). On special conditions the upper platforms of Parklift 461 and 462 may be used as parking places – please contact Wöhr.
4. In case higher loading is required e.g. passage for fire brigade, please contact Wöhr.
5. A locked key arrangement ensures that the unit is always left in the lowered position after each use.
6. A separate maintenance shaft with ladder is required. A safe maintenance access with a door has to be provided by the customer – please contact Wöhr. This shaft is important for ventilation and passage to the pit and can also house the hydraulic power pack.
7. At the edge of the pit a 10 cm wide, yellow-black marking according to ISO 3864 has to be provided by the customer (see “statics and construction requirements“ on page 3).
8. It is not possible to have channels or undercuts and/or concrete haunches along the pit floor-to-wall joints. In the event that channels or undercuts are necessary, the system width needs to be reduced or the pit needs to be wider.
9. The manufacturer reserves the right to construction or model modifications and/or alterations. Furthermore, the right to any subsequent part modification and/or variations and amendments in procedures and standards due to technical and engineering progresses in the art or due to environmental regulation changes, are also hereby reserved.

Width dimensions

All dimensions shown are minimum. Construction tolerances must be taken into consideration.
All dimensions in cm.

The access to the Parklift is possible with max. 3% declination and max. 10% inclination.

Top view closed pit

Single unit

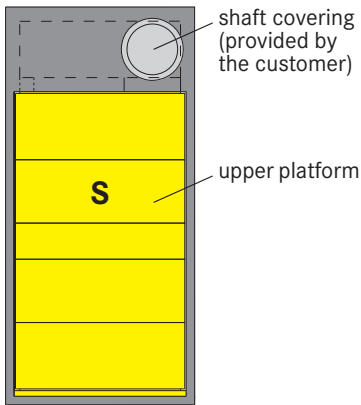

Entrance side

Double unit

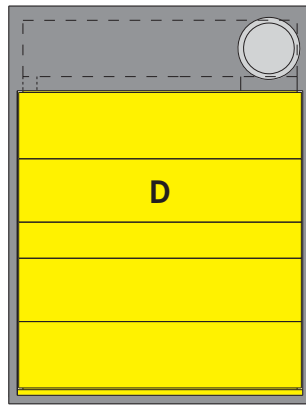

Row arrangement
(Single- and Doubleunits are combinable)

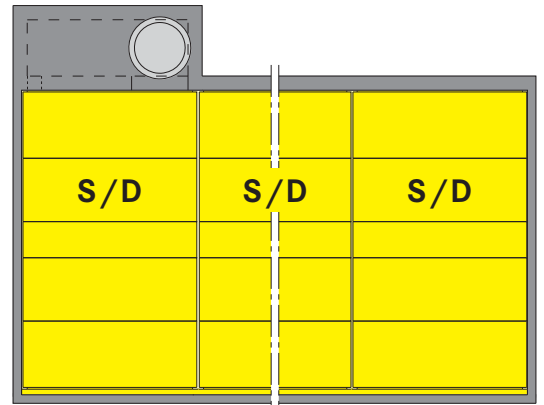

Pit dimensions

Single unit
(front view)

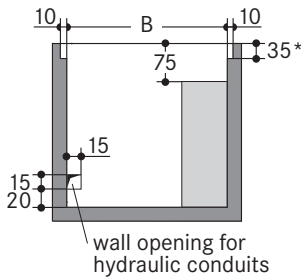

wall opening for hydraulic conduits

Double unit

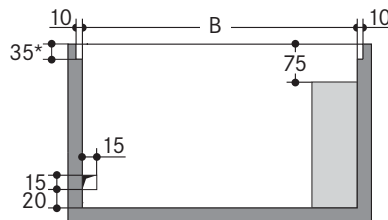

Row arrangement

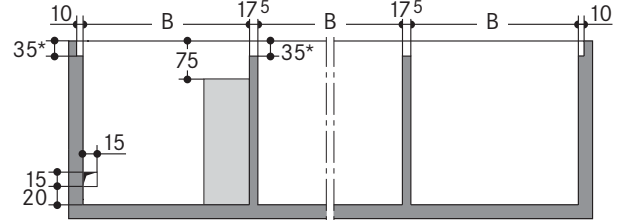

(top view)

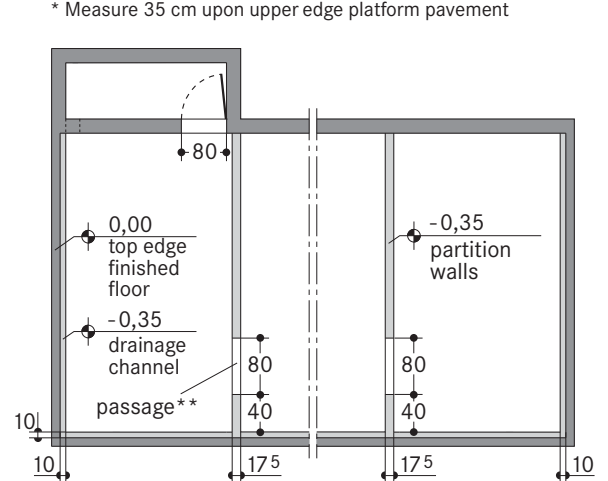
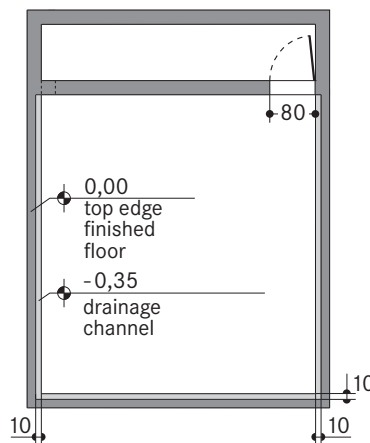
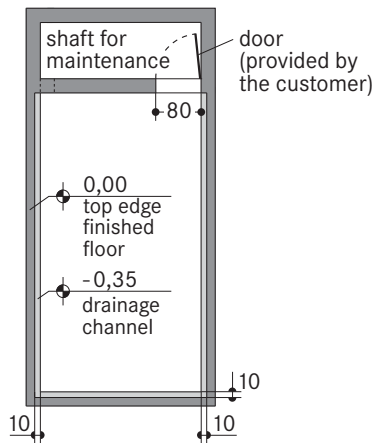

* Measure 35 cm upon upper edge platform pavement

** The passageway to the neighbour units must have the identical height like the passageway of the maintenance shaft in the pit.

Space required B	gives clear platform width	
	parking levels	upper platform
275	230	290
285	240	300
295	250	310
305	260	320
315	270	330

Space required B	gives clear platform width	
	parking levels	upper platform
505	460	520
525	480	540
545	500	560
565	520	580
585	540	600

A rectangular angle is required from the sidewalls to the front side. Max. tolerances are 1 cm!

Important notes

Attention:

If sides or the back are freely accessible, a safeguard is necessary (safety fences, marking, electrical hauling cable counter, or similar). This is planned dependent on project.

Belf maximum platform widths are not installed, difficulties might arise when entering or exiting the cars on the parking units. This depends on the car type, the access and the individual driving behaviour.

Cars wider than 190 cm should be parked on platforms 270/540 cm width only for entering/exiting at drivers position.

Pit edge

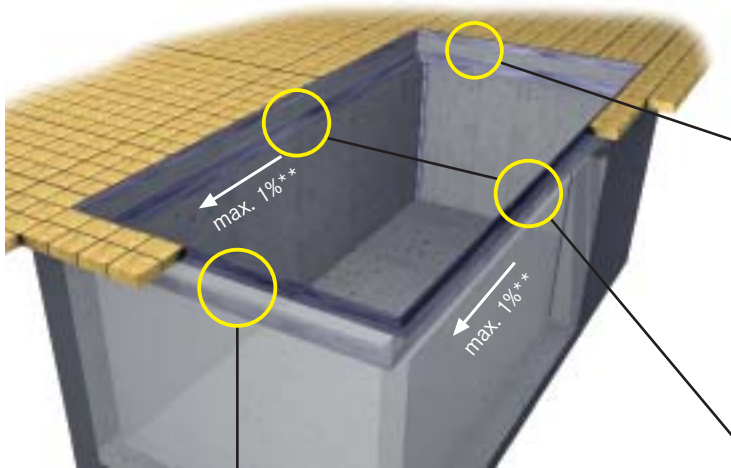
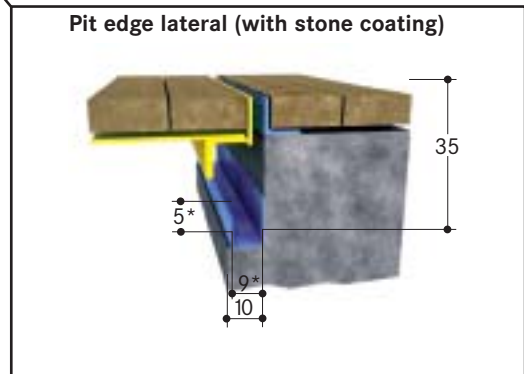
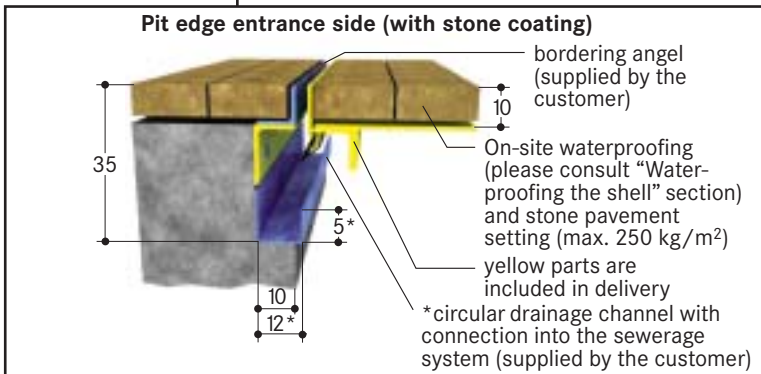
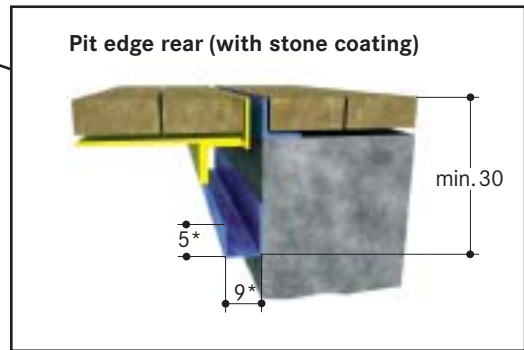

Illustration with stone coating (without Parklift)

** max. 1% slope of drainage channel to entrance side



Installation

For the installation a crane has to be provided by the customer. For installations in underground car parks or roofed areas a mobile crane must be provided by the client, min. hook height 5 m.

Parklift 461:

hook clearance min. 400 cm over height of entrance crane load approx. 700 kg

Parklift 462 and Parklift 463:

hook clearance min. 700 cm over height of entrance crane load approx. 1400 kg

Statics and construction requirements

Bearing loads are transmitted to the pit by base plates, fixed by heavy duty anchor bolts to a depth of approximately 10–12cm. When fixing to waterproof concrete floors chemical anchors are employed (to be advised by Wöhr). Concrete quality according to the static requirements of the building, but for the dowel fastening we require a concrete quality of min. C20/25. The walls of the pit must be formed of

Section

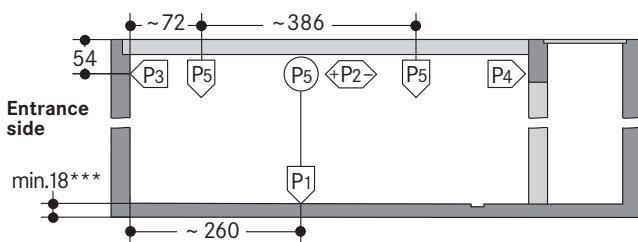

Top view

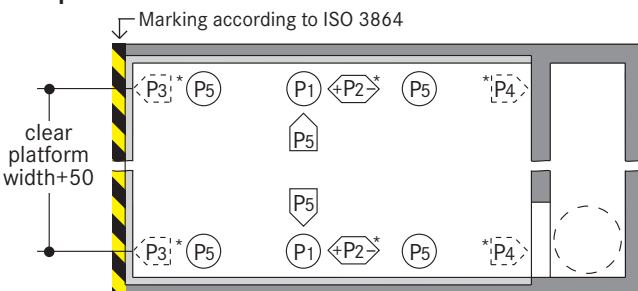

* The force P2 is only given when the pillars are fitted to the side walls. The forces P3 and P4 come only into effect when the pillars can not be fitted to the side walls.

** All static loadings include the weight of the car.

*** The loading capacity of the base plate must be proved by a structural engineer. Possibly stronger base plate could be necessary.

Waterproofing the shell

For on-site waterproofing of the shell, we recommend use of the »SikaCor Elastomastic TF« coating produced by Sika (please observe the product datasheet requirements).

Alternatively, use of comparable waterproofing systems is also possible (subject to prior consultation with the product supplier as to the on-site conditions).

concrete and must be perfectly flat and vertical without any protrusions. Tolerance in the evenness and angularity must be taken additionally into consideration. The specified lengths to the support points are mean values. Please contact us for exact positions for any variations on the standard units.

Statics

Parklift 461 · 2600 kg

Single unit	Double unit
P1 = + 93 kN**	P1 = + 160 kN (upper platform with stone coating)
P2 = ± 13 kN	P2 = ± 17 kN
P3 = + 13 kN	P3 = + 17 kN
P4 = + 13 kN	P4 = + 17 kN
P5 = + 13 kN	P5 = + 13 kN

Parklift 462 · 2600 kg

Single unit	Double unit
P1 = + 121 kN**	P1 = + 208 kN (upper platform with stone coating)
P2 = ± 9 kN	P2 = ± 13 kN
P3 = + 9 kN	P3 = + 13 kN
P4 = + 9 kN	P4 = + 13 kN
P5 = + 13 kN	P5 = + 13 kN

Parklift 463 · 2600 kg

Single unit	Double unit
P1 = + 125 kN**	P1 = + 221 kN (upper platform with stone coating)
P2 = ± 8 kN	P2 = ± 12 kN
P3 = + 8 kN	P3 = + 12 kN
P4 = + 8 kN	P4 = + 12 kN
P5 = + 15 kN	P5 = + 15 kN

Electrical data

Item	Performance	Quantity	Designation	Position	Frequency
1	by customer	1 unit	electric meter	in the feed cable	
2	by customer	1 unit	fuse or automatic circuit breaker 3 x 32 A slow blow acc. to DIN VDE 0100 p. 430	in the feed cable	1 x per power pack
3	by customer	as locally required	acc. to local power supply regulations	feed cable to main switch	1 per power pack
4	by customer	1 unit	separate feed cable (230 V) with lighting and power outlet	from feed cable into the maintenance shaft	1 x per Parklift
5	by customer	1 unit	marked main switch, lockable to prevent unauthorized switching on	outside the pit, max. 20 m away from operating device	1 x per power pack
6	by customer	as locally required	PVC control cable with marked strands and protective conductor 5 x 4 ²	from main switch to hydraulic power pack	1 x per power pack
7	by customer	each 10 m	equipotential bonding safety lead-out connection	corner pit floor/rear wall	
8	by customer	1 unit	equipotential bonding safety compliant to the DIN EN 60204 standard	from the lead-out connection to the system	1 per Parklift
9.1	by customer	as locally required	empty pipe DN40 with taut wire	base pit/operating device	1 x per Parklift
9.2	by customer	as locally required	empty pipe DN40 with taut wire	for feed cable to power pack	1 x per Parklift
10	by customer	as locally required	switch post		1 x per Parklift

Items 11 – 17 are included in Wöhr's scope of delivery unless otherwise specified in the offer/order.

* DIN VDE 0100 part 410 + 430 (not under permanent load)
3 PH + N + PE (three-phase current)

The electrical components supplied by the manufacturer must be connected in accordance with the appropriate wiring diagram and local regulations. German VDE electrical requirements must be adhered to, in order to validate the TÜV tested circuit.

The electrical supply to the power pack(s) must be provided prior to or during installation to

enable our fitters to complete their work satisfactorily and to check the correct functioning of the units.

In compliance with the DIN EN 60204 standard provisions, all systems must be connected directly on site with an earthed equipotential bonding. The lead-out connection must be at a 10 m distance!

Noise protection

Outdoor installation:
The basis is the German DIN 4109 »Noise insulation in buildings«. According to DIN 4109 equipment, machinery and plant used in joint technical facilities in buildings must be provided with adequate protection against air-borne and solid-borne sound.

Indoor installation:
Basis is the German DIN 4109 "Noise protection in buildings".

With the following conditions required 30 dB (A) in rooms can be provided:

- noise protection package from our accessory
- insulation figure of the construction of min. $R_{w} = 57$ dB
- walls which are bordering

the parking systems must be done as single wall and deflection resistant with min. $m' = 300$ kg/m²

- solid ceiling above the parking systems with min. $m' = 400$ kg/m²

At differing constructional conditions additional sound absorbing measures are necessary.

The best results are reached by separated sole plates from the construction.

Increased noise protection:
If increased noise protection must be provided planning has to be confirmed on a project basis by Wöhr (further building measures are required).

Operating device

The position of the operating device depends on the project (switch post, house wall). From

bottom of the shaft to the operating device an empty pipe DN40 with taut wire is necessary.

Conformity test

All our systems are checked according to EC machinery directive 2006/42/EC and EN 14010.

Dimensions

All dimensions shown are minimum. Construction tolerances must be taken into consideration. All dimensions in cm.

Hydraulic power pack

The power pack will be placed in the shaft for maintenance.

Parking place width

We recommend a clear platform width of at least 250 cm and/or of at least 500 cm for double systems.

Installation diagram

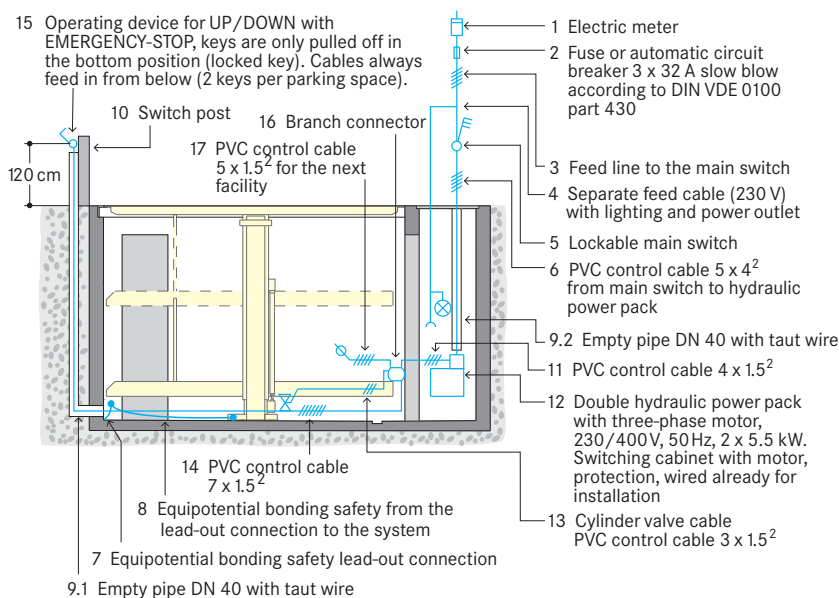

Temperature

The installation is designed to operate between -20° and $+40^{\circ}$ C. Atmospheric Humidity: 50% at $+40^{\circ}$ C. If the local circumstances differ from the above please contact Wöhr.

Illumination

Illumination has to be considered acc. to local requirements by client. Illumination in the shaft for maintenance minimum 80 Lux.

Railings

During the building phase the pit has to be safeguarded by the customer.

Drainage (to be performed by the customer)

- 1) Before the installation, it is necessary, from part of the building site, to have an all-around drainage channel, made of concrete with a connection to sewerage system.
- 2) For locations with particularly exposed conditions we recommend an additional drainage channel around the outside of the pit.
- 3) We recommend the provision of a drainage channel at the rear of the pit which can either incorporate a pump sump
- 4) To prevent any possibility of contamination of the ground water we recommend giving the pit floor an oil resistant coating as a means of protecting the environment. If this is to be connected to the sewerage system, it is advisable to provide oil and/or petrol separators.

Ventilation

We recommend to provide a ventilation system in consultation with heating/ventilation/air conditioning engineers with the aim of obtaining continuous air exchange, reducing air humidity,

preventing condensate and reducing moisture from cars (rain, snow, ice etc.). This helps considerably to reduce or to prevent corrosion and malfunctions due to corrosion.

Maintenance

WÖHR and our foreign partners have an assembly and customer network. Annual maintenance is performed at conclusion of a maintenance contract.

Protection against corrosion

Independent of a maintenance workings has to be carried out acc. to Wöhr Cleaning and Maintenance Instruction regularly.

Clean up galvanized parts and platforms of dirt and road salt as well as other pollution (corrosion danger)!

Pit must be always ventilated and deaired well.

Maintenance Shaft

A separate shaft for maintenance with an entrance to the pit is necessary. On serial garages a shared maintenance shaft may be suitable but will depend on individual projects. The covering and ladder for the shaft is the clients responsibility.

Fire safety

Each and every fire safety requirement and all possible mandatory item(s) and equipment(s) (fire extinguishing systems and fire alarm systems, etc.) are to be provided by the customer.