

DETAIL A: NEW JOIST TO WALL DETAIL

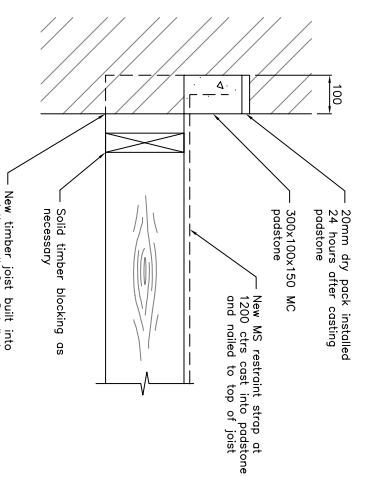

DETAIL B: RESTRAINT STRAPS PARALLEL TO JOISTS

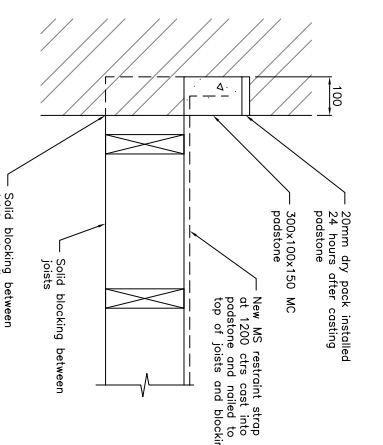

DETAIL C: RESTRAINT STRAPS PERPENDICULAR TO JOISTS

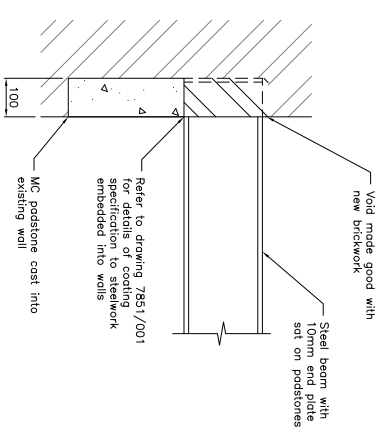

DETAIL D: BEAM BEARING INTO EXISTING WALL

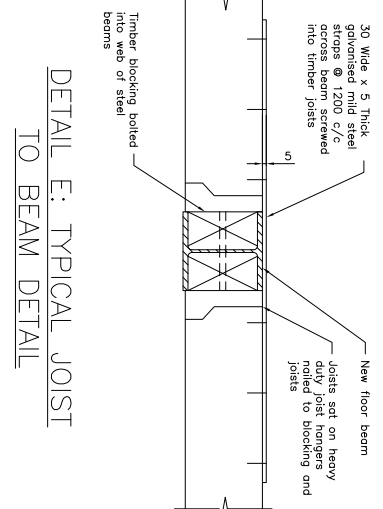

DETAIL E: TYPICAL JOIST TO BEAM DETAIL

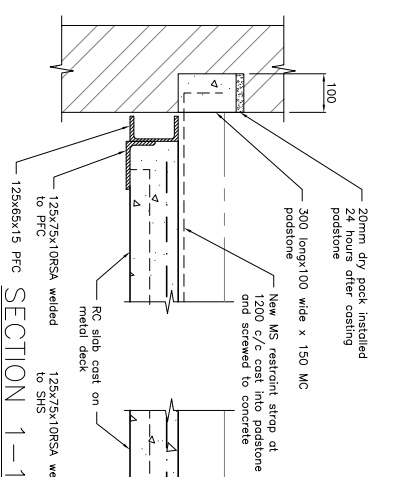

SECTION 1-1

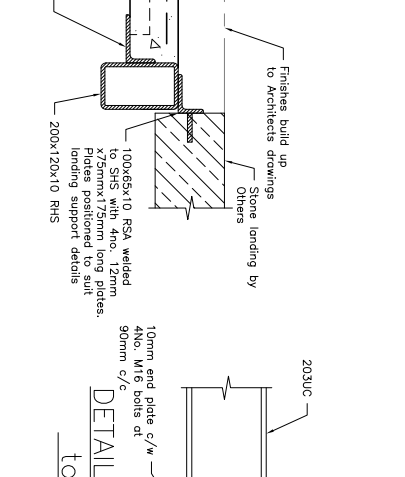

DETAIL F: 203UC TO 254UC

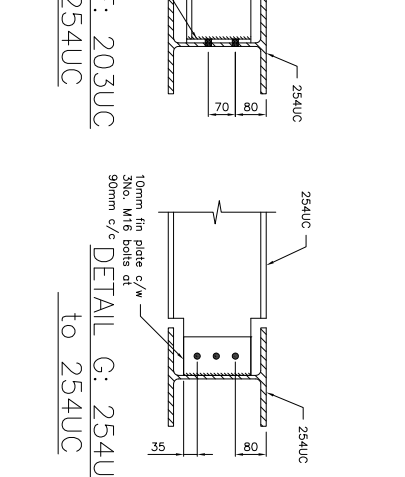

DETAIL G: 254UC TO 254UC

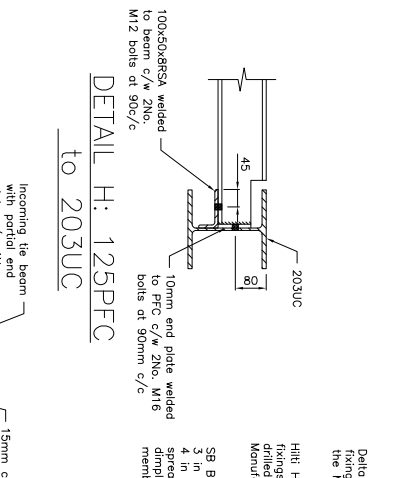

DETAIL H: 125PFC TO 203UC

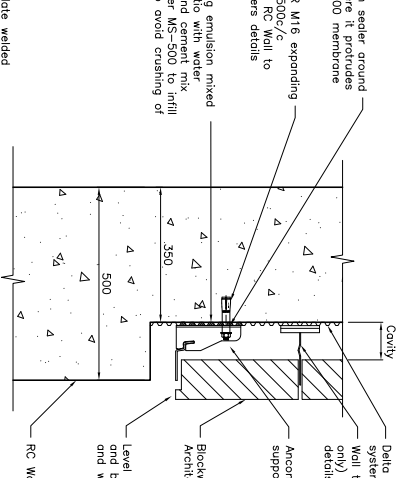

BRICK SUPPORT BRACKET DETAIL BS1

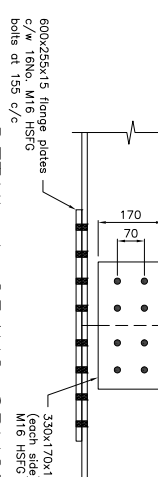

DETAIL J: 254UC SPLICE

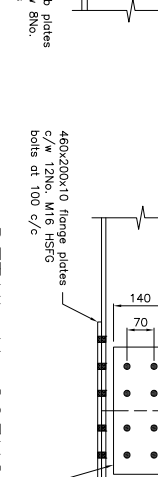

DETAIL K: 203UC SPLICE

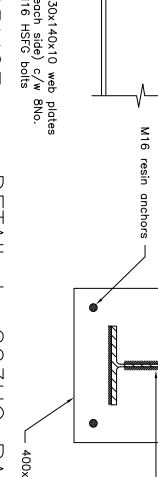

DETAIL L: 203UC BASEPLATE

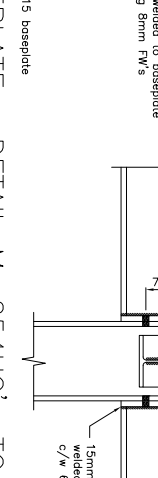

DETAIL M: 254UC'S TO COLUMN

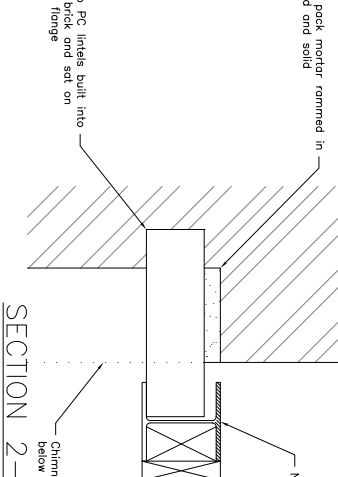

SECTION 2-2

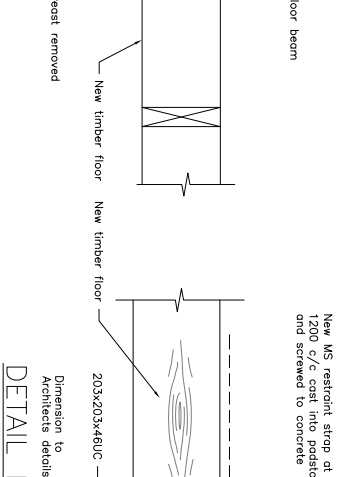

DETAIL N

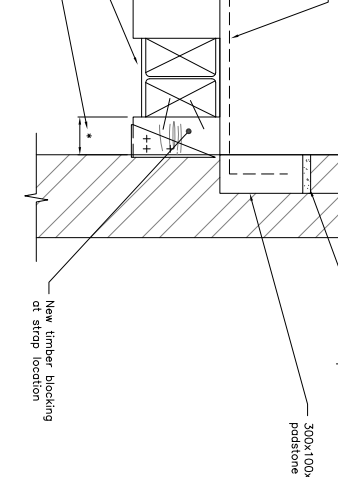

SECTION 3-3

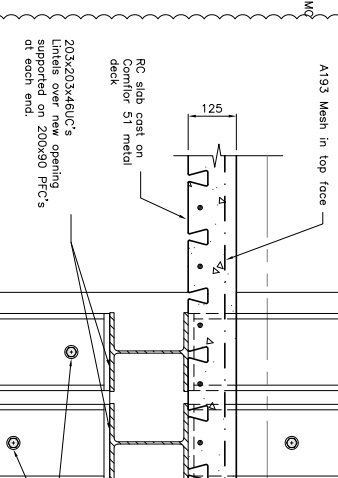

SECTION P-P

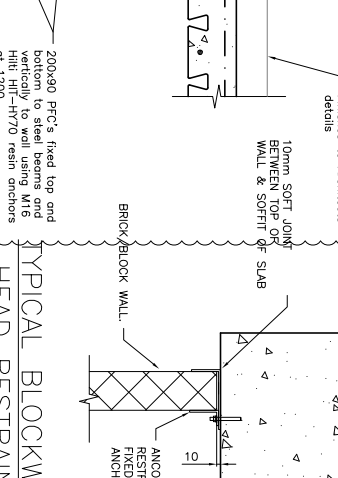

TYPICAL BLOCKWALL HEAD RESTRAINT DETAIL

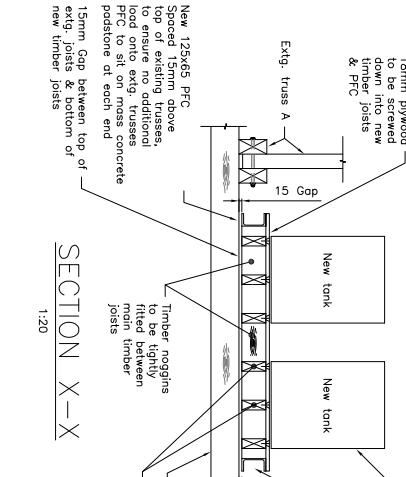

SECTION X-X

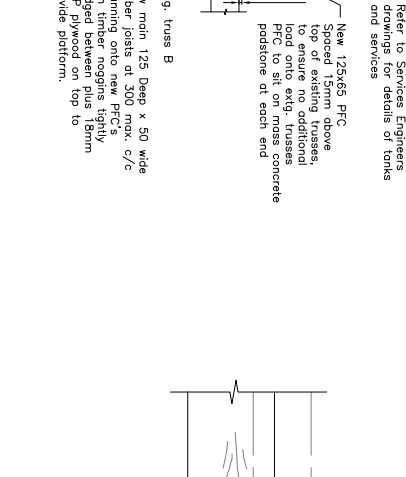

SECTION 1-20

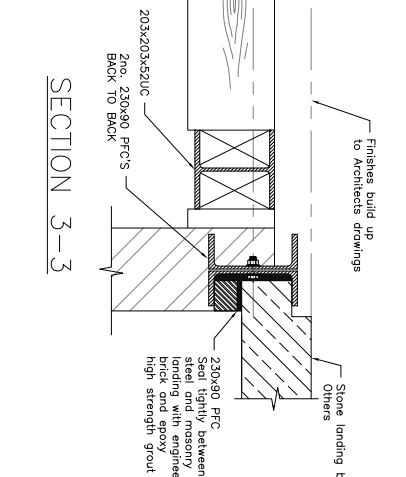

SECTION 3-3

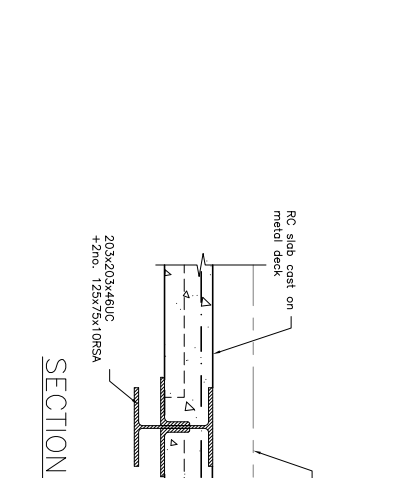

SECTION 4-4

- NOTES:**
- All structural engineering drawings are to be read with the specification and with all relevant Architect's and Service Engineer's drawings and specifications.
  - Do not scale from this drawing in either paper or digital form. Use written dimensions only. To check drawing has been printed to intended scale this bar should be 50mm long @ A1 or 25mm long @ A3.
  - All dimensions are in millimetres and levels in metres.
  - Refer to drawing 7851/001 for further notes.

Rev	Date	Description
G	27.05.15	DS Detail P-P revised
F	12.05.15	DS Details added
E	06.02.15	DUP Section A-F added
D	01.12.14	DUP Issued for Construction Following further information from Architect
C	12.11.14	DS Issued for construction approval
B	07.11.14	TM Issued for construction approval
A	24.04.14	TM Issued for tender
-	11.10.13	1B Issued for comment / coordination. Amendment

Status: **CONSTRUCTION**

**SINCLAIRJOHNSTON**  
Consulting Civil & Structural Engineers

93 Great Suffolk Street  
London SE1 0BX  
T: 020 7593 1910  
F: 020 7593 1910  
www.sinclairjohnston.co.uk

41-42 CHESTER TERRACE,  
NW1

SECTIONS & DETAILS  
PROPOSED

Drawn: T Watson Scale: 1:10 at A1  
Project No./Drawing No: 7851/030 Rev: G