

**KEY @ 1:20**

( Read in conjunction with Drawing No. C(0)021 & C(0)022)

**SECTION YY**

**SECTION ZZ**

**A**

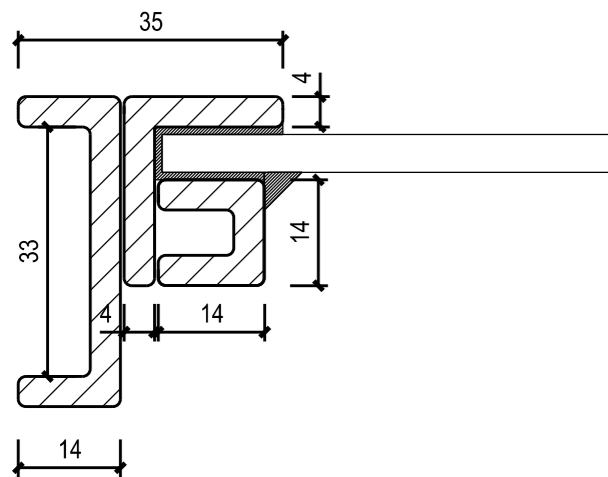

**SECTION ZZ**

**B**

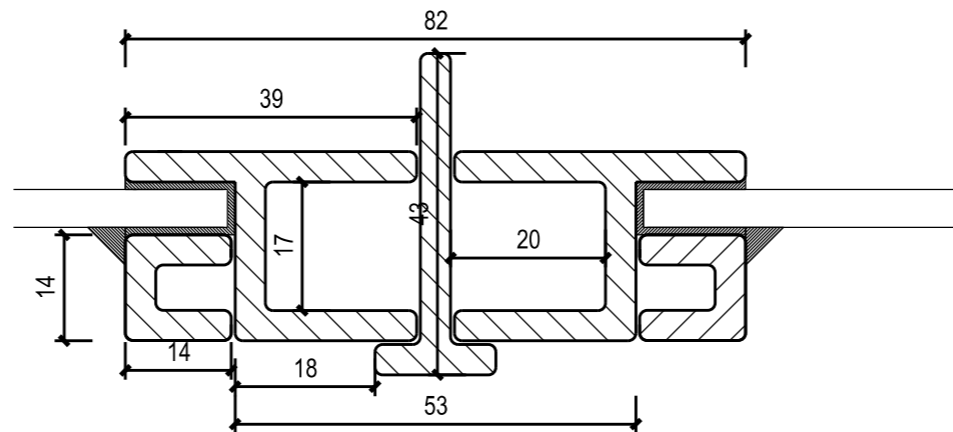

**SECTION ZZ**

**C**

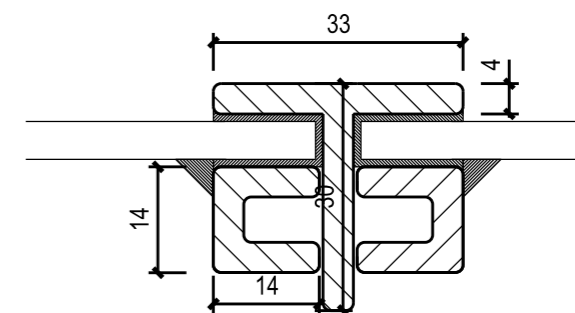

**SECTION ZZ**

REV.	DESCRIPTION	DATE	DRN BY	CHK BY
P1	Planning Issue	30.03.15	AR	MB

PROJECT	Heals Refurbishment Phase 2
TITLE	Fifth Floor Steel Window Type 52 & 53 Details
CLIENT	Threadneedle Property Investments Ltd

JOB No.	5354	DRAWING No.	C(0)033	REVISION	P1
SCALE	1:1 @ A3	DRAWN BY	AR	CHECKED BY	MB
STATUS	Planning	DATE	March 2015		

**j**marchitects

2nd Floor  
Threeways House  
40-44 Clipstone Street  
London  
W1W 5DW  
T: 0207 580 5330  
F: 0207 436 5348  
lon@jmarchitects.net  
www.jmarchitects.net