

(c) UKMap Copyright, The GeoInformation Group 2013 Licence No. LANDMLON10000912118

LOCATION PLAN ~ 1:1250

N

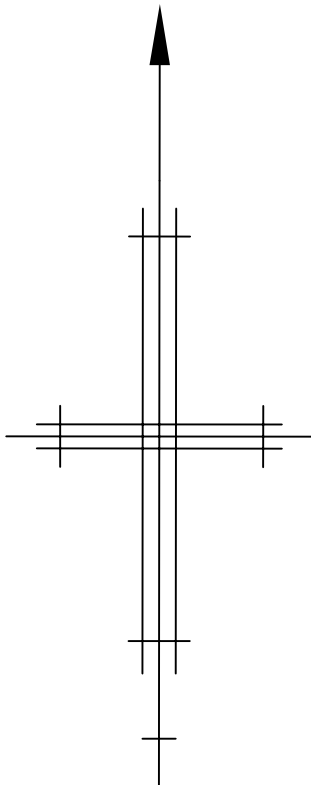

REV B - Ground floor depth reinstated as built
 REV A - Entire rear wall moved forwards 940mm
 REVISIONS

14/02/2014
 13/02/2014
 DATE

**Architectural
 Design & Planning**

32 Grange Road
 Plymouth PL7 2HY

t: 01752 341696
 f: 01752 342503

**THE DESIGN
 WORKS**

TITLE

LOCATION PLAN

ADDRESS

33c MILL LANE
 LONDON NW6 1NZ

CLIENT

COBSTAR Ltd

SCALE

1:1250

© A4

DATE

FEBRUARY 2013

DRAWING No.

121214/P/03

REV.

B