

Door Type D4

Doors: DG.23

leaf size: 426 x 1923

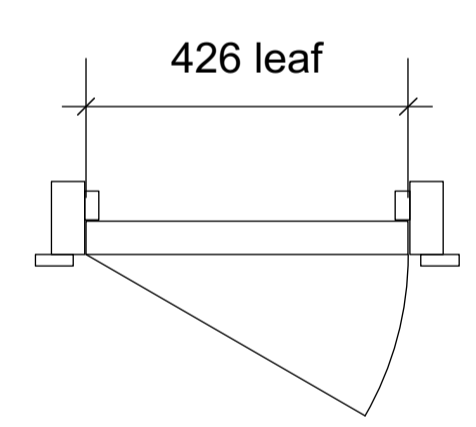

Door Type D5

Doors: DG.40

leaf size: 426 x 2040

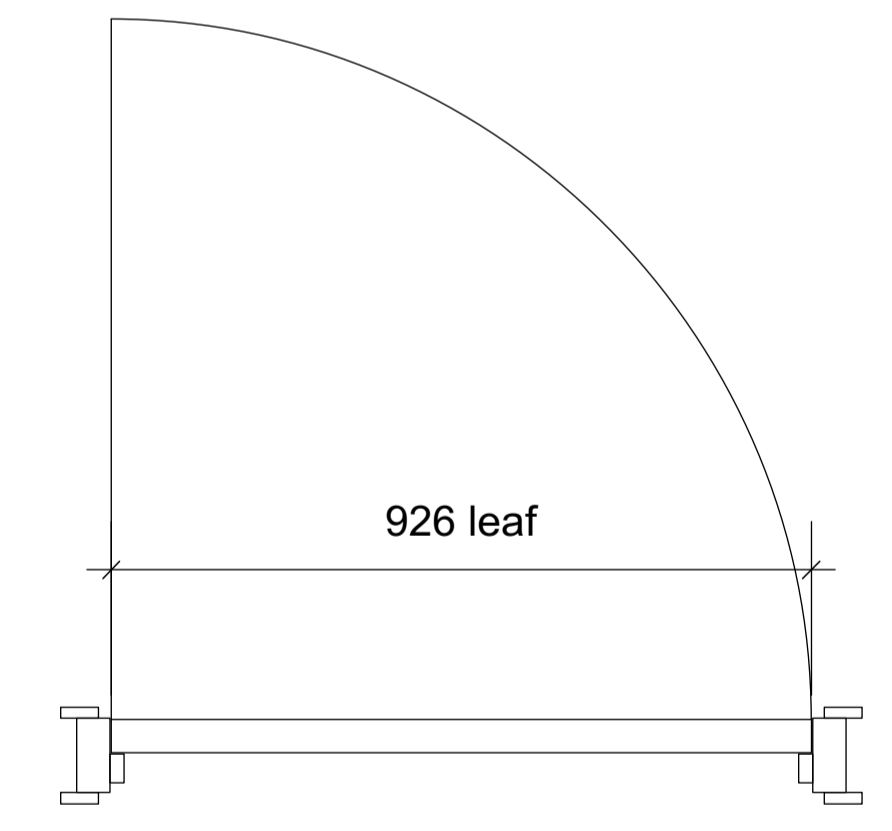

Door Type D6f (FD 30 S)

Doors: DF.02

leaf size: 926 x 2040

GENERAL NOTES

1. This drawing is the copyright of Haines Phillips Architects.
2. Do not scale from this drawing. Use figured dimensions only.
3. This drawing must not be used for land transfer purposes, or for construction purposes unless accompanied by an Architect's instruction.

FILE REFERENCE
Details/Door Elevations



DRAWING ISSUE STATUS

ISSUE	STATUS	COMMENT
SK	SKETCH	
P	PRELIMINARY	For comment and review
PL	PLANNING	Planning/ Listed Building Application
T	TENDER	For pricing purposes only
C	CONSTRUCTION	For procurement & construction
AB	AS-BUILT	Record drawings on completion
L	LEGAL	Conveyancing or other legal purposes

REVISIONS

REV	DATE	NOTES
1	10/2014	Preliminary Issue.
2	27/1/15	Notes and details added.

HAINES PHILLIPS
ARCHITECTS

Tankerton Works
12 Argyle Walk
London WC1H 8HA
020 7833 9324
020 7837 2864
office@hainesphillips.co.uk

JOB TITLE
LAUDERDALE HOUSE
Highgate N6 5HG

DRAWING TITLE
DOOR ELEVATIONS
DOOR TYPES D4, D5, D6

DRAWN DATE
ED 10/2014
SCALE
1:10 @ A1
JOB NR DRAWING NR ISSUE REV
3712 DA 412 P 2