

01 Shopfront Elevation
1:50@A3

03 1:50@A3
Section A

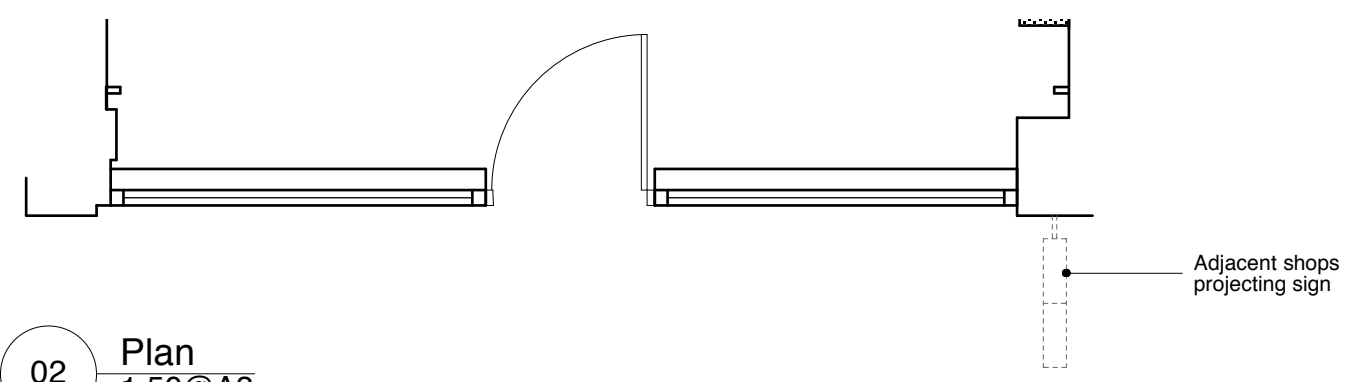

04 Photo of Existing Shopfront
N.T.S



02 Plan
1:50@A3



- B 19.03.15** External lighting added to Planners request received 18.3.15
- A 11.03.15** Vertical glazing bars to upper section added to Planners comments (not previously supplied on the external survey by others) & revised building survey incorporated due to incorrect elevation

DESCRIPTION
Existing Shopfront

CLIENT
Barkers
PROJECT
Hampstead
ADDRESS
57 Southend Road, NW3

JOB No. DWG No. REV.
558 00.3 B

DATE. STATUS.
MAR 2015 D3

DWN BY
EC
SCALE
1:50@ A3

PATH
Unit 5, 7 Wenlock Road, London N1 7SL
T +44 (0)20 7253 9005 F +44 (0)20 72539004
www.pathdesign.co.uk info@pathdesign.co.uk

THIS DRAWING IS FOR DESIGN INTENT PURPOSES ONLY.
 • This drawing is issued on condition that it is not copied or disclosed to any other unauthorised person without the prior written consent of PATH DESIGN.
 • Contractors should provide their own setting out drawings or comment by PATH DESIGN.
 • This drawing is the property of PATH DESIGN and copyright is reserved by them.
 • All structural works are to be detailed / confirmed and approved by structural engineer.
 • All dimensions to be verified on site prior to work commencing.