

ACCESS LADDER  
Material: Aluminium  
Finish: Self-Colour

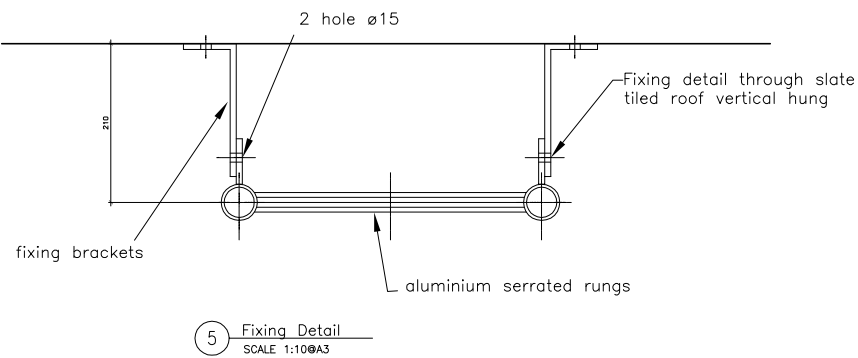

**NOTE**

**Description**

Aluminium access ladder to suit a height as required

**Manufacture**

Manufactured in aluminium. Consisting of 48.3mm (Size 8) stringers set 400mm apart with rungs at 250mm centres.

**Stays**

Set at 2.4m centres with a cage commencing 2.5m from ground level

**Finish**

Aluminium self finished

**Note**

All access systems and fire escapes are designed in accordance with BS5395: Part 3: 1985 and comply with relevant building Regulations.

1 Access Ladder Elevation A  
SCALE 1:20@A3

2 Access Ladder Elevation B  
SCALE 1:20@A3

5 Fixing Detail  
SCALE 1:10@A3

For Discussion	14.11.17	JS	GW
----------------	----------	----	----

**PLANNING**

Do not scale from this drawing. Check all dimensions and areas on site

**darling  
associates**

Greencoat House 15 Francis Street London SW1P 3DT  
t: 020 7630 0500 f: 020 7630 9059 e: mail@darlingassociates.net

Project:  
• 74 Charlotte Street  
• London W1  
Title:  
• External Access Ladder Details  
•

Project No:	Drawing No:	Revision:
• 14069	• (PL)04	• -
Scale:	1:10@ A1	1:20@ A3
Drawn:	JS	Issue:
2014.11.17		GW

The design is the copyright of darling associates limited