

DECKING OMITTED FOR CLARITY

3d

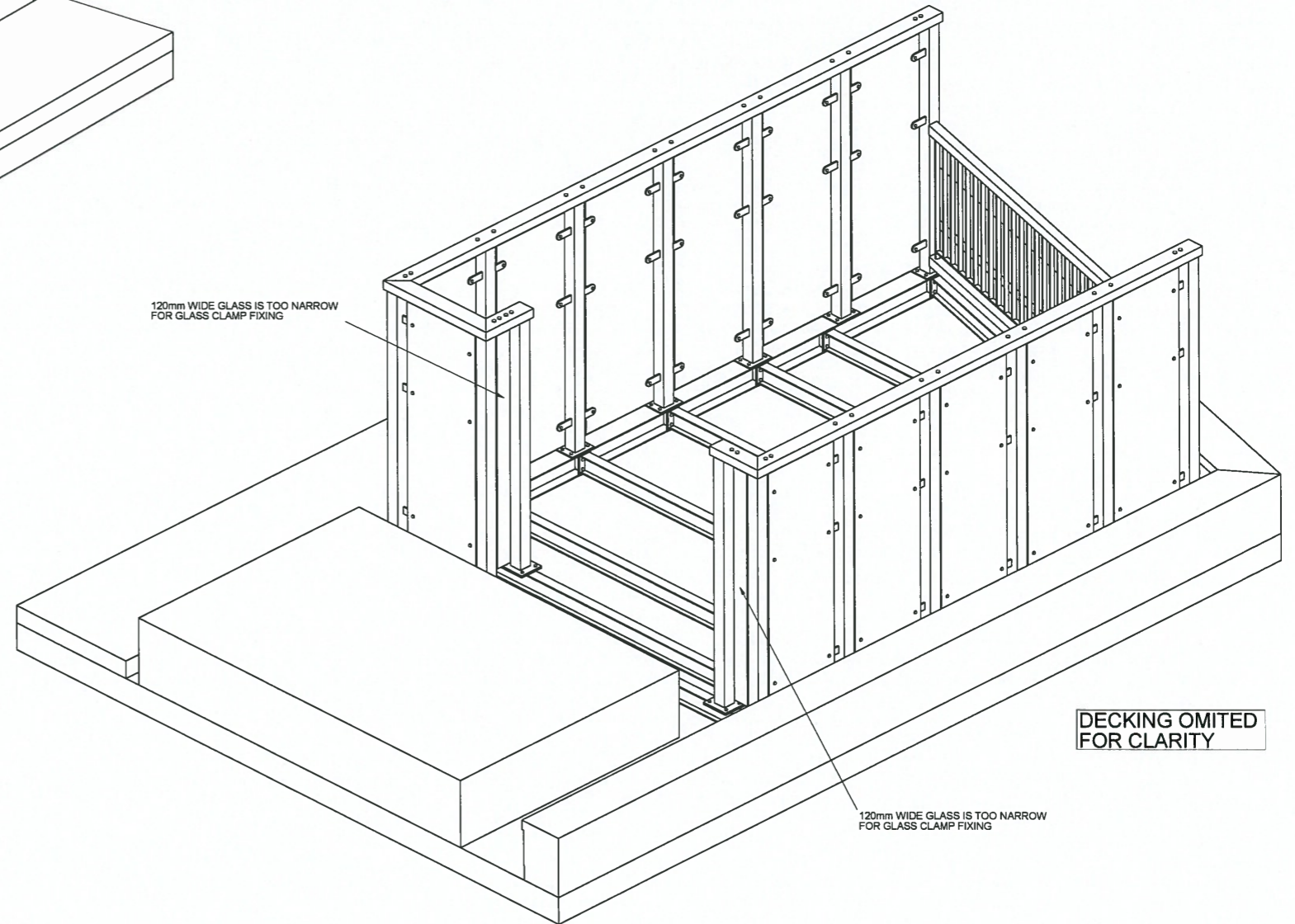

120mm WIDE GLASS IS TOO NARROW FOR GLASS CLAMP FIXING

DECKING OMITTED FOR CLARITY

120mm WIDE GLASS IS TOO NARROW FOR GLASS CLAMP FIXING

3d - 3d

GALVANISED AND  
PPC RAL 7021

ALL GLAZING  
TO BE OBSCURE GLASS

1	P1	PRELIMINARY ISSUE	7/5/14
REV No	REMARK	REVISION DESCRIPTION	REVISION DATE
<b>elitemetalcraft</b>			
DRAWING TITLE		A1_GA_DRAWING	
CONTRACT			
MODELLED BY	SO	ISSUE DATE	00.00.0000
CONTRACT NO	41489	SCALE	1:20
DRAWING No	G [2]	REVISION No.	1



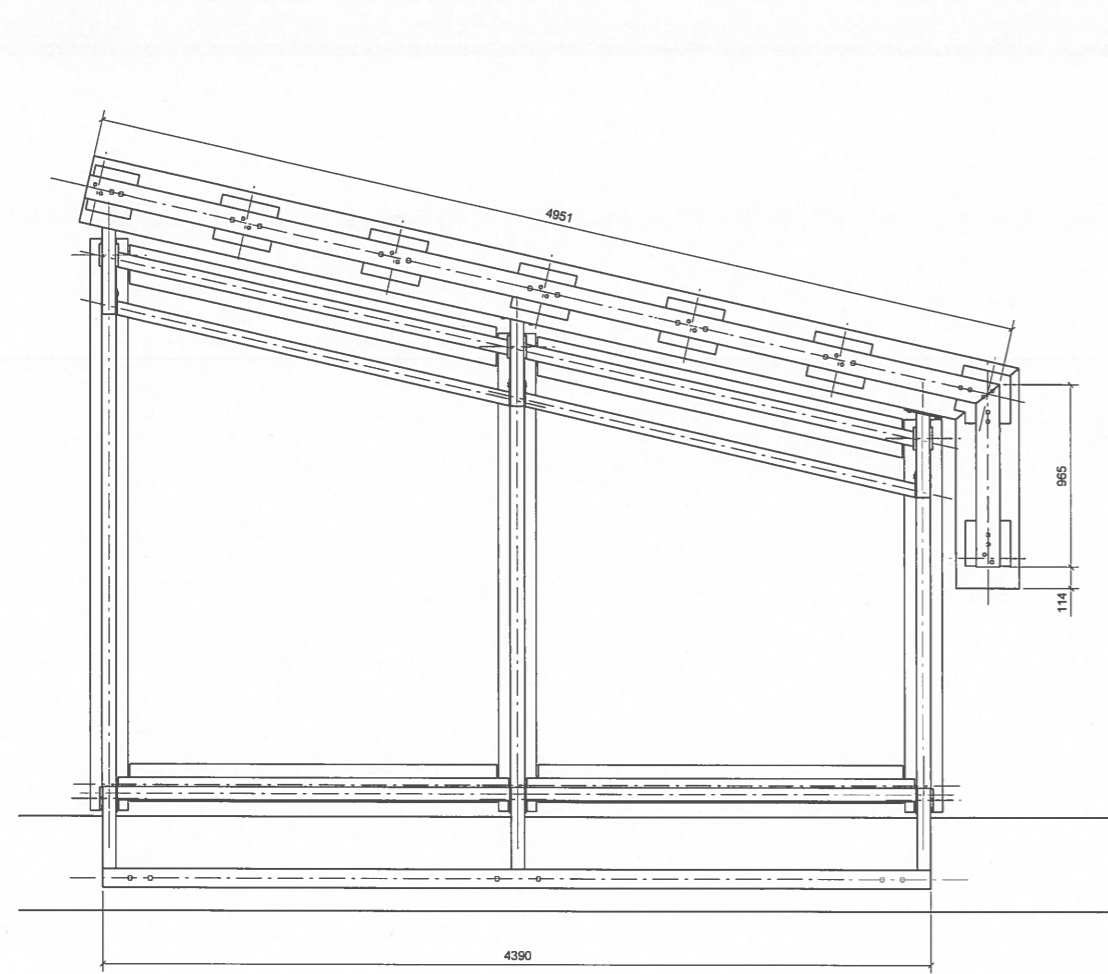

Plan +0

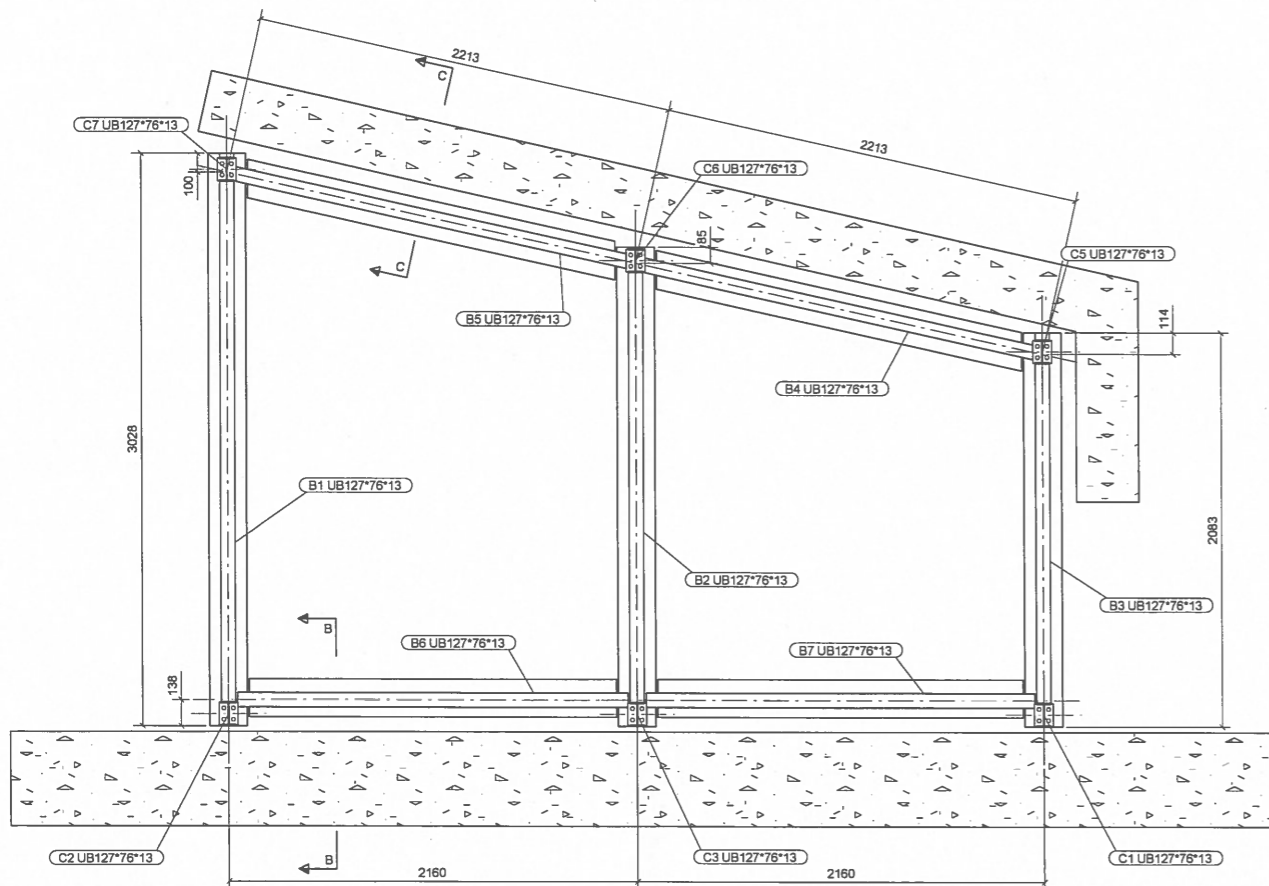
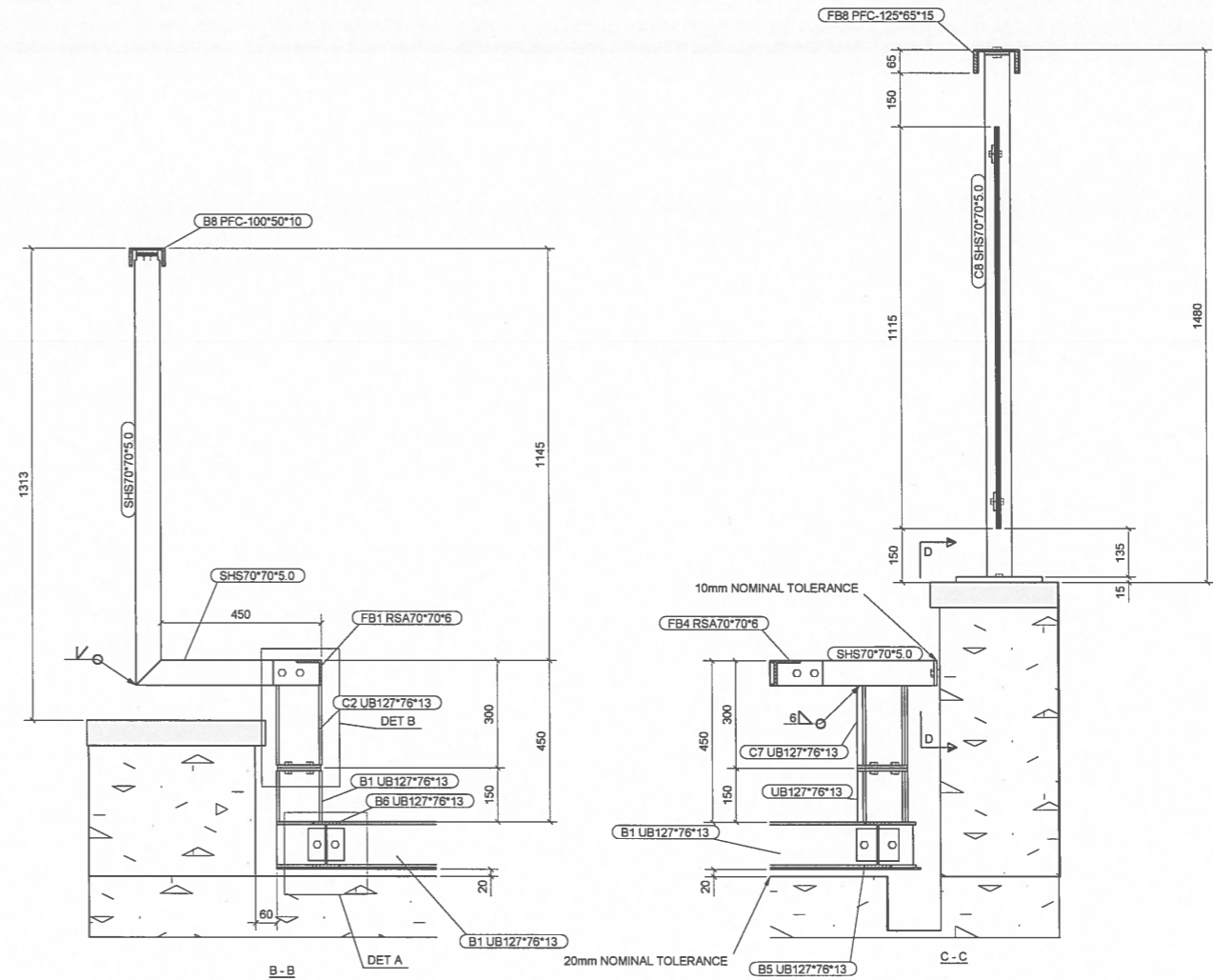

SECTION OF LOWER LEVEL

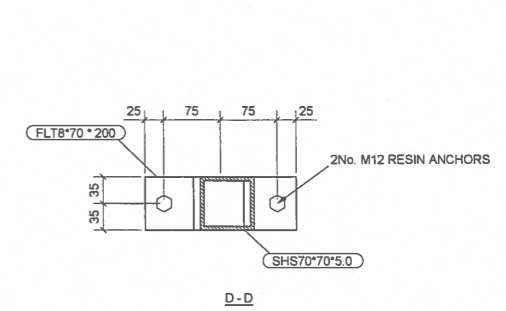
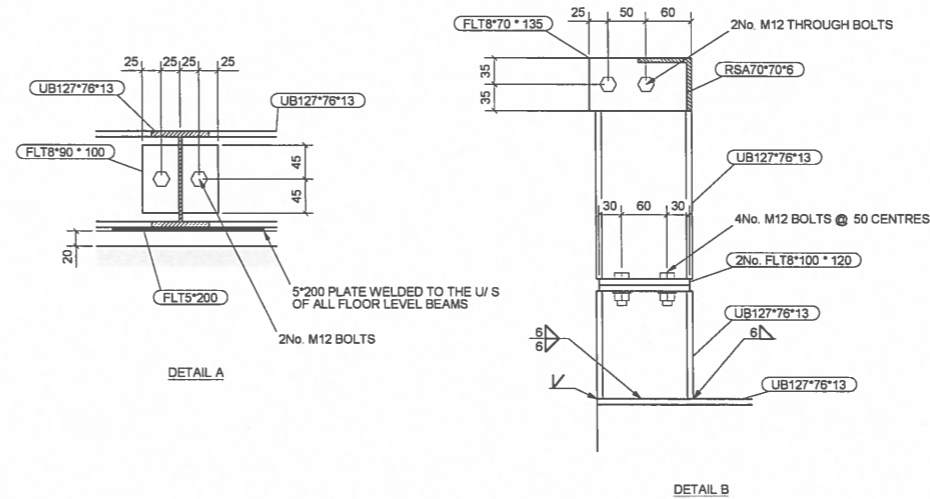

1	P1	PRELIMINARY ISSUE	24/2/14
REV No	REMARK	REVISION DESCRIPTION	REVISION DATE
<b>elitemetalcraft</b>			
28-02-05			
DRAWING TITLE		A1_GA_DRAWING	
CONTRACT			
MODELLED BY	SO	ISSUE DATE	00.00.0000
CONTRACT NO	40952	SCALE	1:10 1:20 1:5
DRAWING No	G [1]	REVISION No.	1



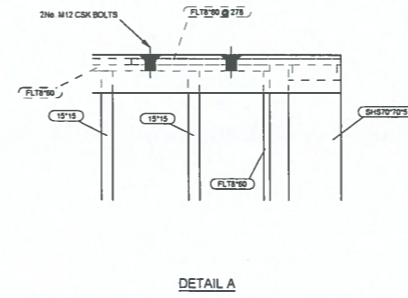
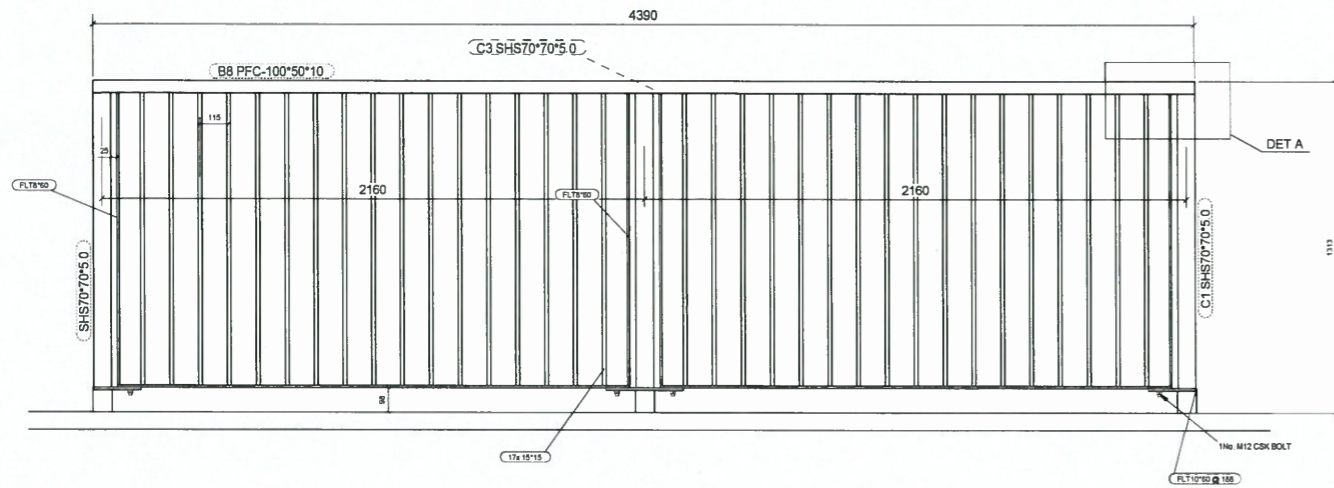

ALL GLAZING TO BE  
OBSCURE GLASS

ELEVATION ON GAURD RAIL

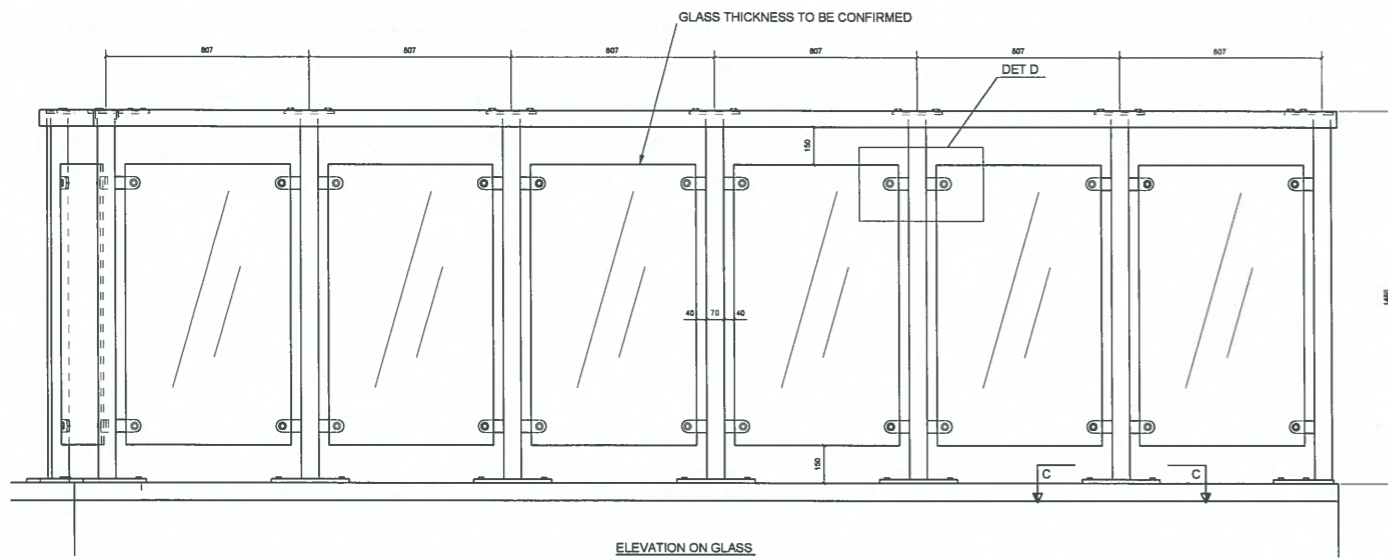

ELEVATION ON GLASS

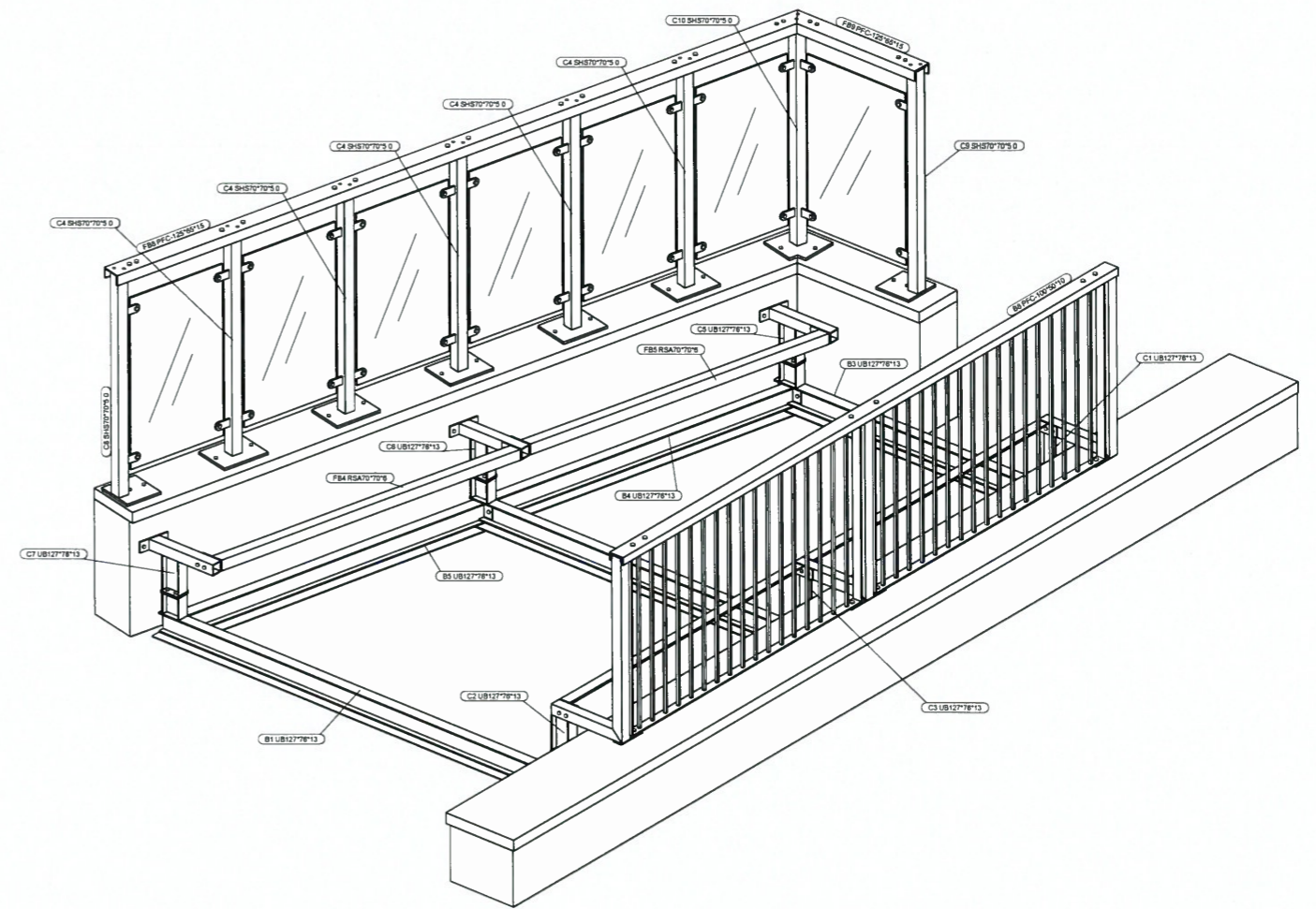

3d - 3d  
SECTION OF LOWER LEVEL

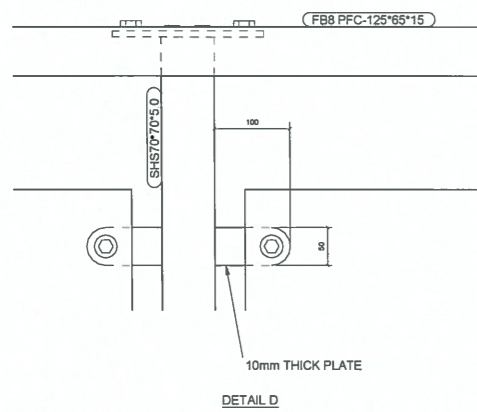

DETAIL D

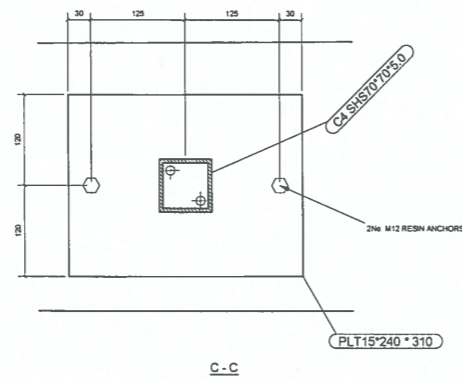

C - C

REV No	REV MARK	REVISION DESCRIPTION	REVISION DATE
1	P1	PRELIMINARY ISSUE	24/2/14
<b>elitemetalcraft</b>			
28-02-05			
DRAWING TITLE		A1_GA_DRAWING	
CONTRACT		SO	
MODELLED BY		SO	
CONTRACT NO		40952	
DRAWING No		G [2]	
ISSUE DATE		00.00.0000	
SCALE		1:15 1:20 1:5	
REVISION No.		1	