

**Notes:**  
 1. This drawing is copyright of the client. It is the property of the client and is not to be reproduced without the client's written consent.  
 2. The client is responsible for the accuracy of the information provided in the specification and for the accuracy of the information provided in the drawings.  
 3. The client is responsible for the accuracy of the information provided in the specification and for the accuracy of the information provided in the drawings.  
 4. The client is responsible for the accuracy of the information provided in the specification and for the accuracy of the information provided in the drawings.  
 5. The client is responsible for the accuracy of the information provided in the specification and for the accuracy of the information provided in the drawings.  
 6. The client is responsible for the accuracy of the information provided in the specification and for the accuracy of the information provided in the drawings.  
 7. The client is responsible for the accuracy of the information provided in the specification and for the accuracy of the information provided in the drawings.  
 8. The client is responsible for the accuracy of the information provided in the specification and for the accuracy of the information provided in the drawings.  
 9. The client is responsible for the accuracy of the information provided in the specification and for the accuracy of the information provided in the drawings.  
 10. The client is responsible for the accuracy of the information provided in the specification and for the accuracy of the information provided in the drawings.

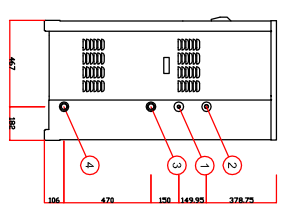

- ① LIQUID LINE CONNECTION (NEW TABLE)
- ② DISCHARGE LINE CONNECTION (NEW TABLE)
- ③ PURGE/WATER INLET
- ④ PURGE/WATER OUTLET
- ⑤ PURGE/WATER INLET
- ⑥ MAIN ISOLATOR HANDLE (REMOVABLE)

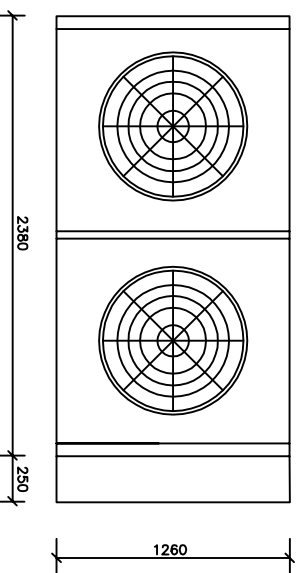
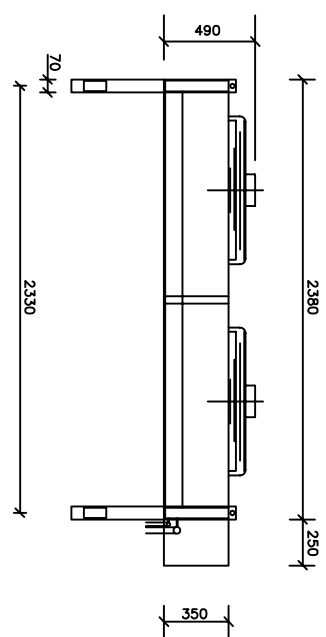
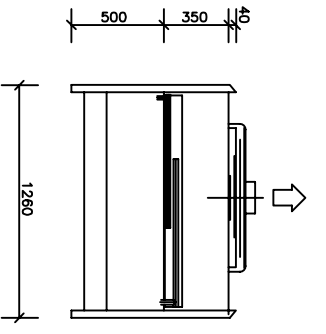
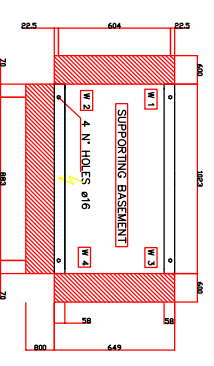
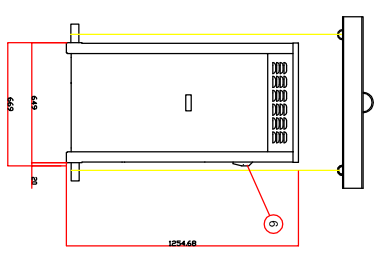
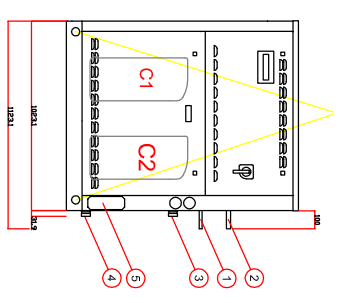

SIZE	WEIGHT DISTRIBUTION (kg)				TOTAL
	W1	W2	W3	W4	
2015	51	76	59	84	270
2018	53	78	62	87	280
2020	54	80	65	91	290
2025	55	80	67	92	295
2026	56	82	68	94	300

Ø LIQUID/DISCHARGE LINE	Ø LIQUID/DISCHARGE LINE	
	①	②
Ø 16mm	Ø 22mm	
Ø 18mm	Ø 22mm	
Ø 22mm	Ø 28mm	

### AIR COOLED CONDENSING UNIT

Colour of the air cooled condensing unit to be confirmed but to be dark in appearance.  
 All pipework to be hidden from view and installed away from the front face of the building.

### CHILLER UNIT

Chiller unit located in vaulted area below pavement.

### PLANT DETAILS

DRAWING ISSUED FOR PLANNING PURPOSES

Project Name	UCL Pepper Laboratory
Client	UCL
Location	London WC1H 0AH
Project Details	New Chiller Installation
Plant Details	
Contract No.	UCL-M003
Revision	P1

**encred**  
 Engineering Asset Management  
 23 Abchurch Lane, London  
 EC4N 3DF  
 T: +44 (0)20 7064 8221