

NOTES

- 1 This drawing is to be read in conjunction with all relevant Architects, Engineers and specialists drawings and specifications.
- 2 Do not scale from this drawing in either paper or digital form. Use written dimensions only. To check drawing has been printed to the intended scale the above bar should be 100mm long @ A1 or 50mm long @ A3

COLUMN SCHEDULE

C1	203 UC52
C2	139.7x10 CHS
C3	300sq RC column

BEAM SCHEDULE

B1	203 UC52
B2	165x171/305x82.0 USFB. S355 Precambered
B3	200x150x8.0 RHS
B4	152 UC30
CB1	500wd x 1000dp RC downstand beam
CB2	300wd x 600dp RC beam
DJ	Double joists
WP1	200x50 timber resin bolted at 600mm c/c

PROPOSED LEGEND

1	300mm thick RC ground bearing slab
2	225mm thick RC suspended slab
3	300mm thick RC suspended slab
4	150mm thick composite deck metal deck with A393 mesh
5	200x50 C16 timber joists at 400mm c/c with 18mm PLY over glued and screwed to top face

PADSTONES LEGEND

PS1	440g x 215dp x 100wd MC padstone
PS2	330g x 215dp x 100wd MC padstone

PILECAP SCHEDULE

PC1	1000x1000x600dp MC pad
PC2	925wdx600dp RC capping beam

P1	20.11.14	DP	BW	PRELIMINARY ISSUE
Rev	Date	Drawn	Eng	Amendments

HEYNE TILLETTS STEEL
STRUCTURAL ENGINEERS

Job Name:
**4 WEDDERBURN ROAD
NW3**

Drawing Title:
PROPOSED FIRST FLOOR DETAILS

Scale: As indicated at A1

Purpose of Issue: **PRELIMINARY**

Drawing No. **1220 / 111** Rev. **P1**

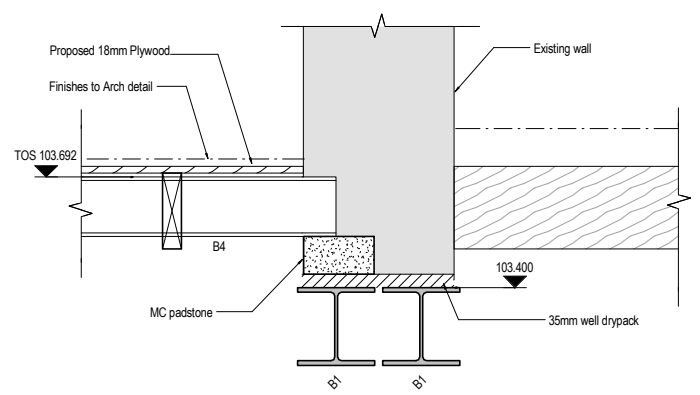

DWG **DETAIL 01**
110 1:10

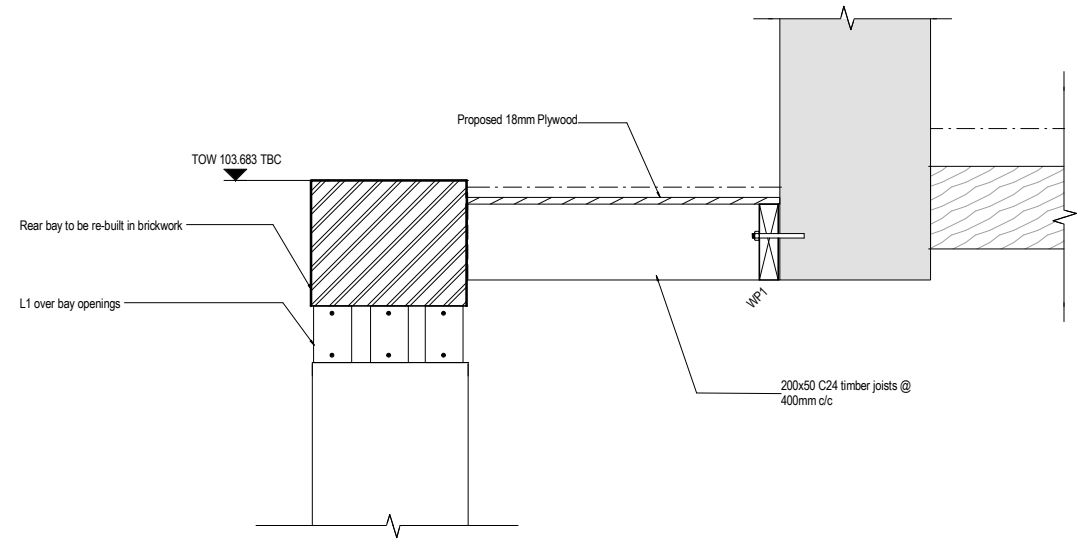

DWG **DETAIL 02**
110 1:10

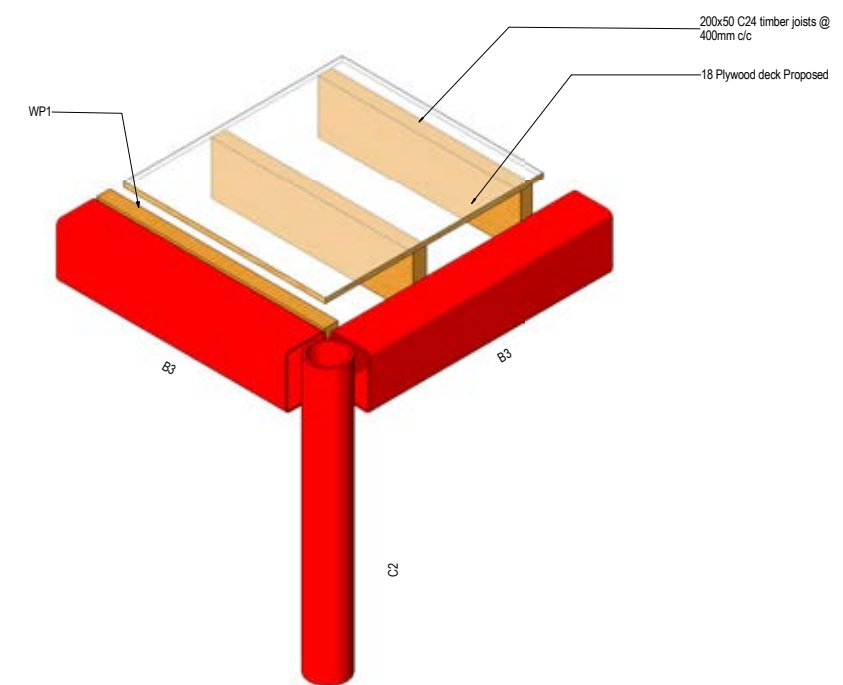

DETAIL 03 - 3d

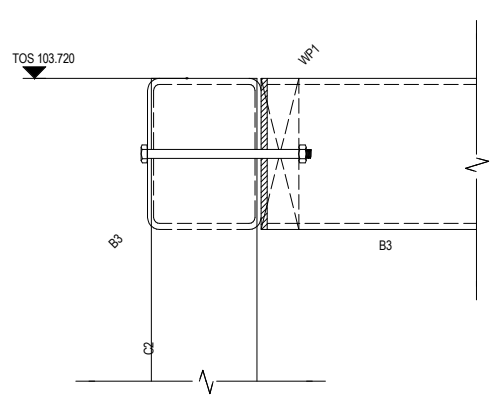

DWG **DETAIL 03 - SECTION**
110 1:5