

# 11 POND STREET NW3 - EXISTING

1:50 @ A2

THIS DRAWING IS TO BE READ IN CONJUNCTION WITH ALL OTHER PLANNING & LISTED BUILDING APPLICATION DRAWINGS & DOCUMENTATION, AND IS TO BE USED FOR PLANNING & LISTED BUILDING APPLICATION PURPOSES ONLY

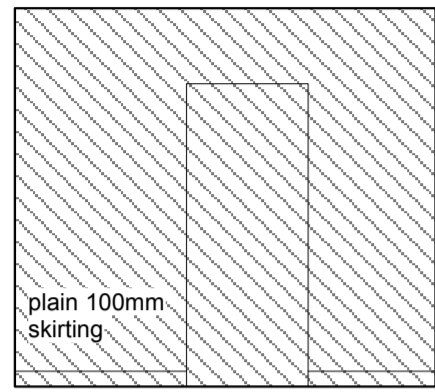

WEST - A

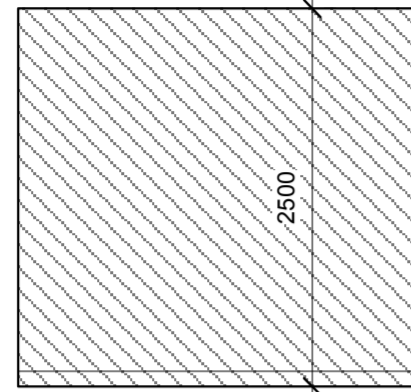

NORTH - B

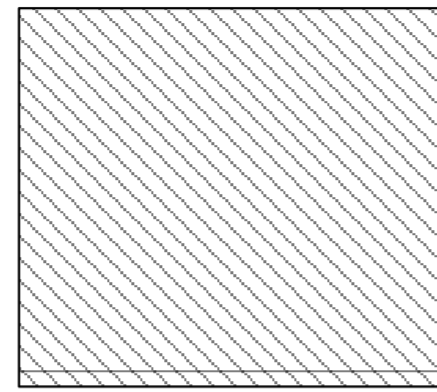

EAST - C

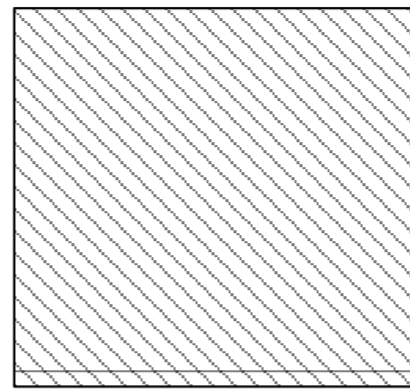

SOUTH - D

## GROUND FLOOR REAR ADDITION - STORAGE 2

modern construction - 1982 addition

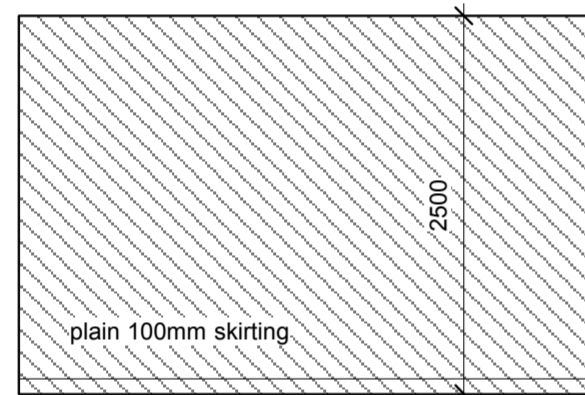

WEST - A

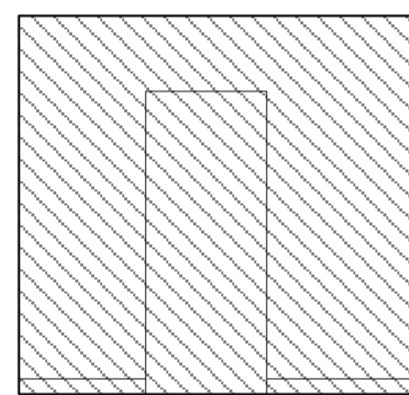

NORTH - B

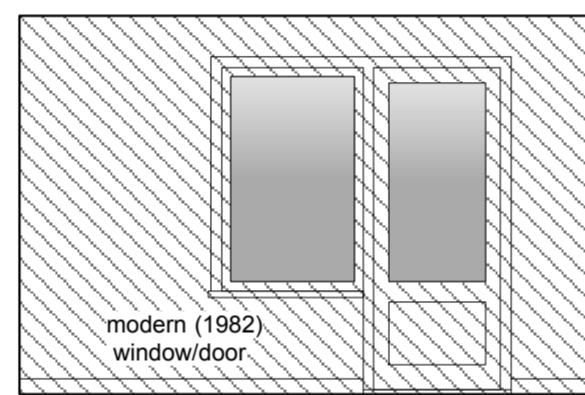

EAST - C

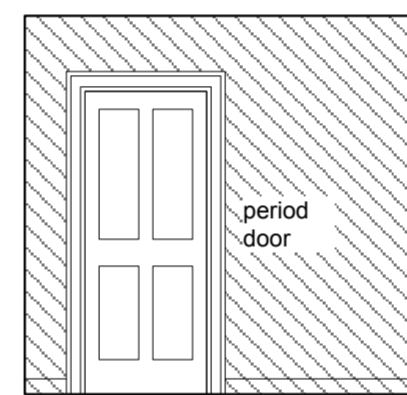

SOUTH - D

## GROUND FLOOR REAR ADDITION - STORAGE 1

modern construction - 1982 addition

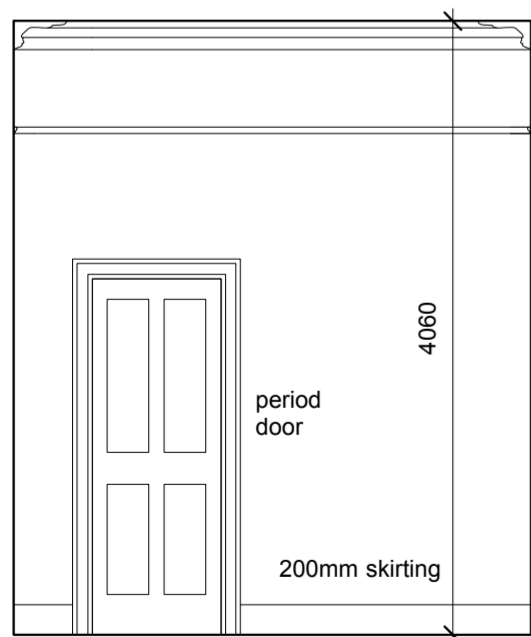
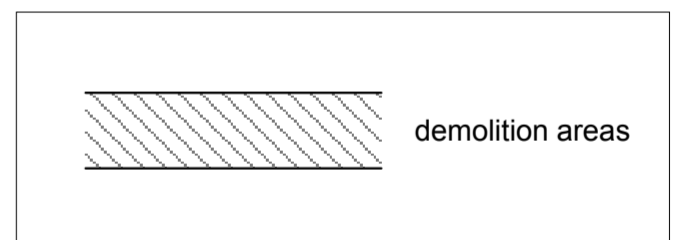

WEST - A

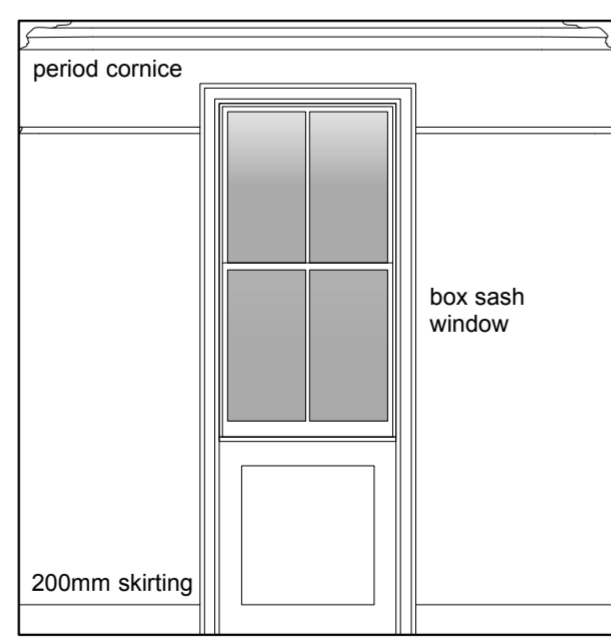

NORTH - B

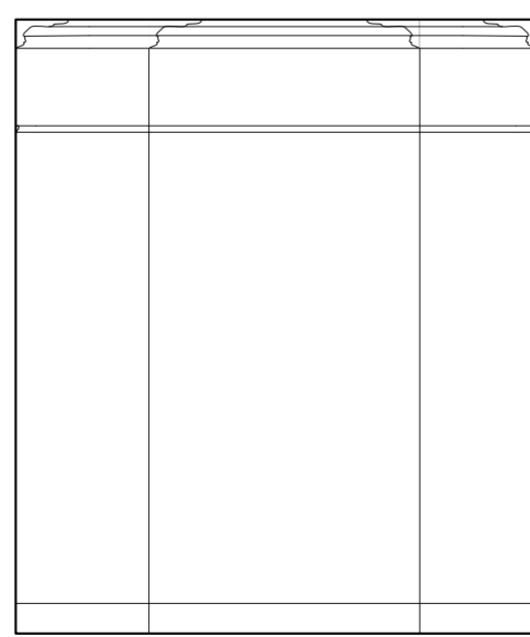

EAST - C

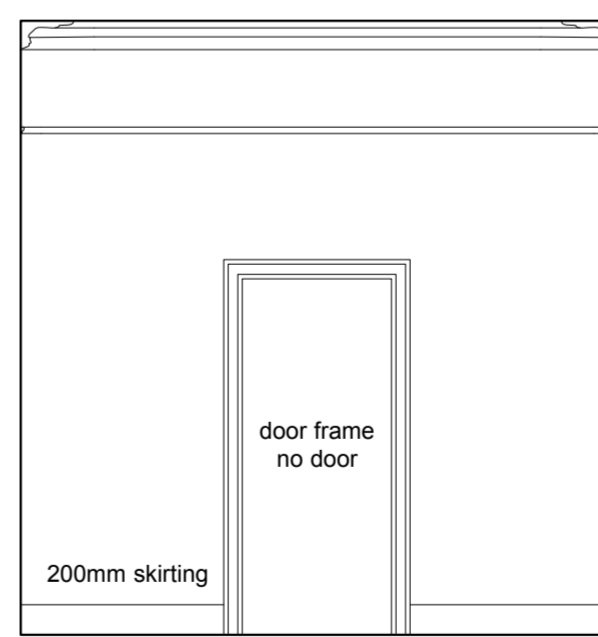

SOUTH - D

## GROUND FLOOR REAR ROOM - OFFICE

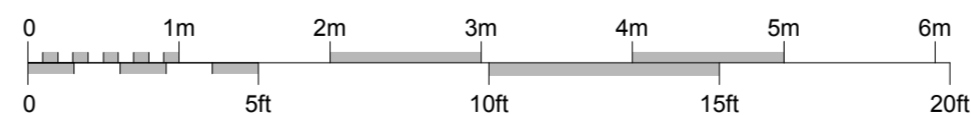

**Brod Wight**  
ARCHITECTS

TEL 020 7722 0810 FAX 020 7722 0939 E MAIL office@brodwight.co.uk WEB www.brodwight.co.uk  
75 Haverstock Hill London NW3 4SL

11 POND STREET - LONDON NW3

INTERNAL ELEVATIONS - EXISTING (2)

1039-S07

Date October 2014 Scale 1:50@A2 This drawing is copyright

Revisions