

ELEVATION C

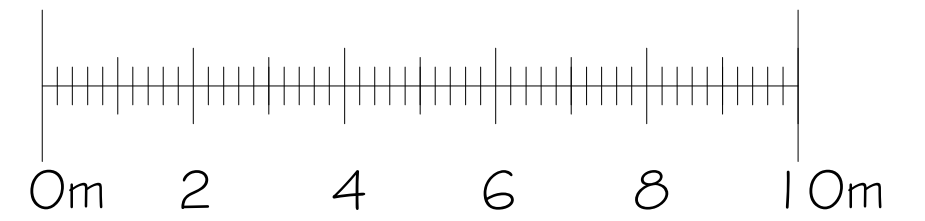

ELEVATION LAYOUT

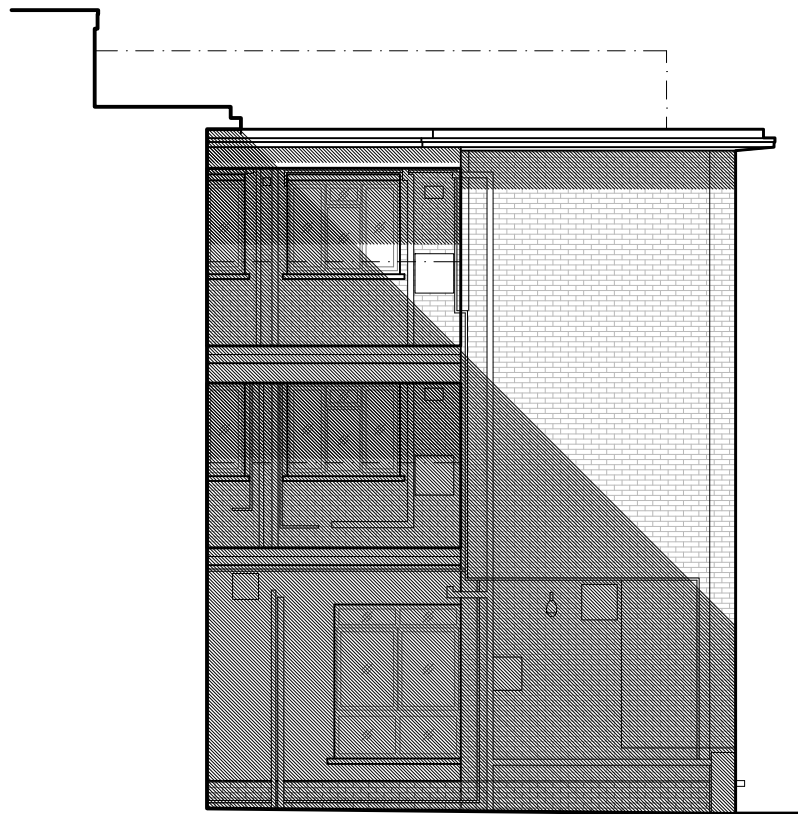
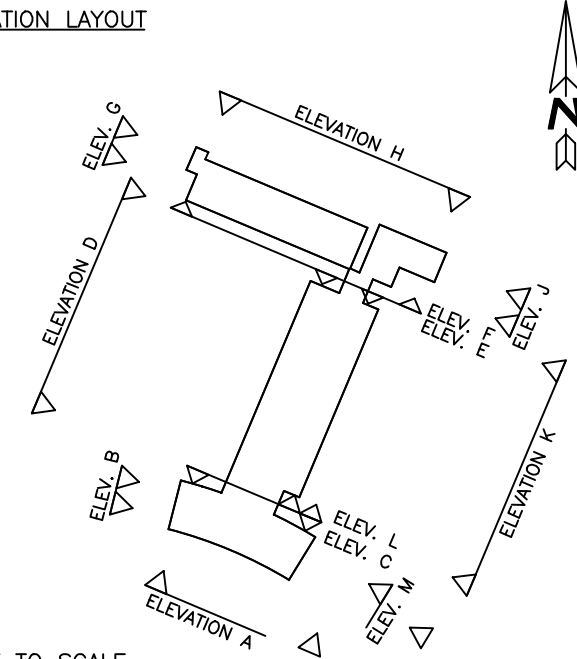

NOT TO SCALE



ELEVATION E

Existing Elevations
Scale 1:100 @ A-3

Ref:1325/G148/02 Rev:

1-48 Greenwood
London
NW5 2BB



Client: Lakehouse



Drawn by: SF
Date: 2nd October 2014

pod LLP
Unit 1.3
13 The Leathermarket
Weston Street
London SE1 3ER



Tel: 020 3176 5590
Mob: 07808 037 998
Email: simon@podpartnership.com
Web: www.podpartnership.com

