

NOTE: - ALL HANDINGS ARE VIEWED FROM DRIVE SIDE. LEFT HAND ROTATIONS ARE DIRECT MIRROR IMAGE

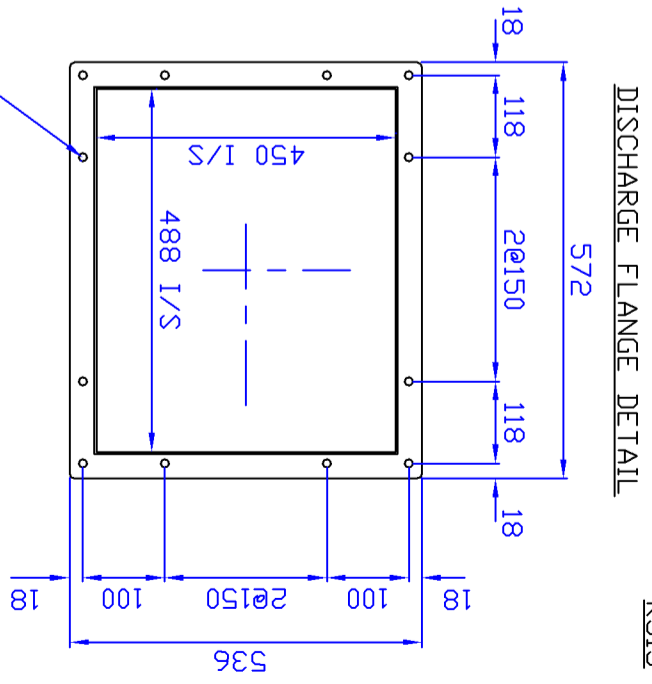
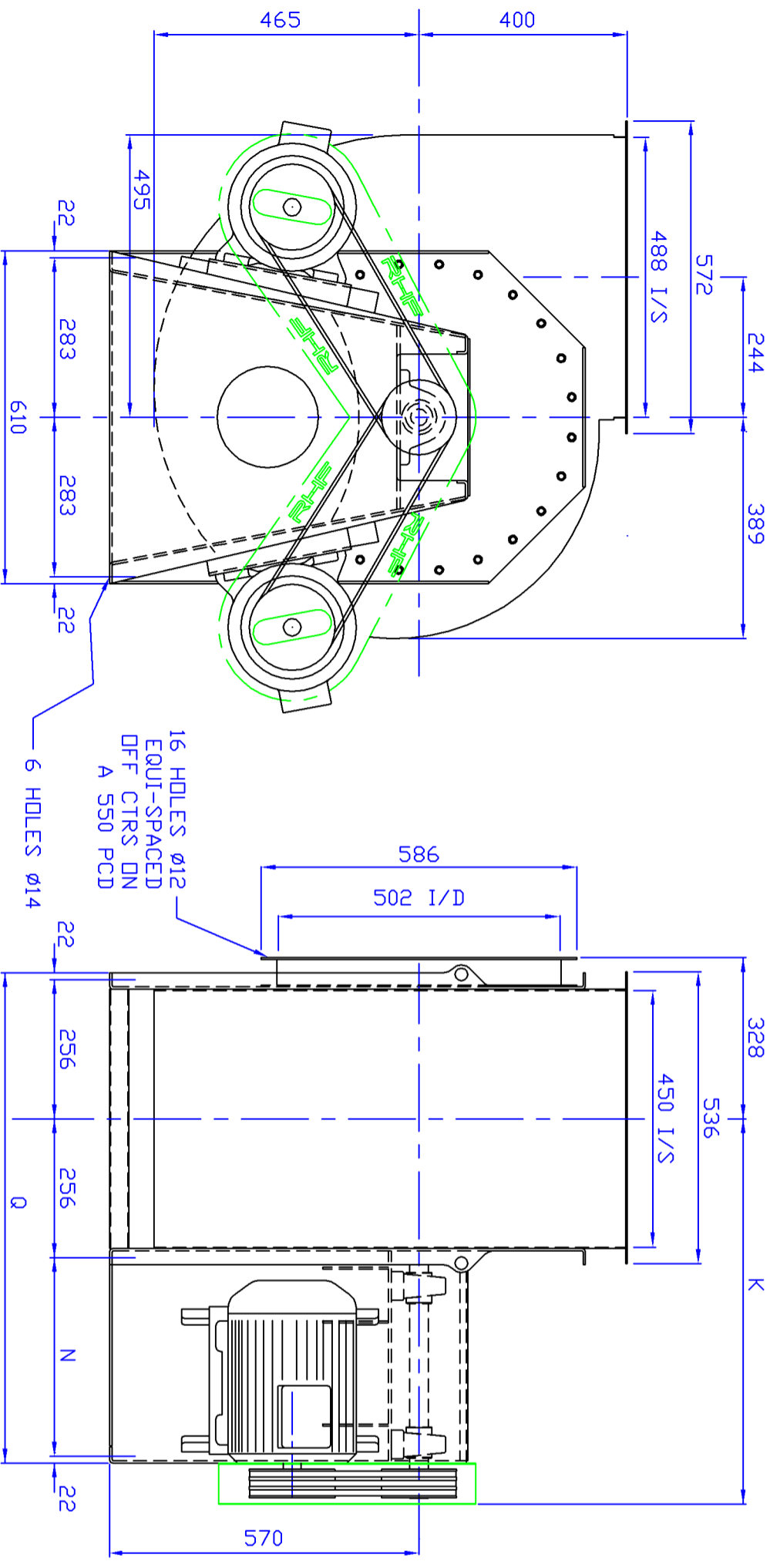

MOTOR FRAME SIZE	N	Q	K
- 132M	420	976	818
160M - 160M	500	1056	918

NOTE: - MOTOR POSITION "A" LHS OF PEDESTAL (AS SHOWN) /POSITION "B" RHS (AVAILABLE)

NOTE: - MOTOR TERMINAL BOX POSITION MAY VARY FROM THAT AS SHOWN DEPENDING ON MOTOR MANUFACTURER

ORDER DETAILS		FAN FEATURES & ANCILLARY ITEMS SUPPLIED ON THIS ORDER		DRIVE DETAILS		MOTOR DETAILS	
CUSTOMER NAME:-				FAN PULLEY:-		Make:-	
CUSTOMER D/No:-				FAN BUSH:-		Kw:-	
DATE:-	RHF WORKS No:-			MOTOR PULLEY:-		rpm:-	
DUTY:-				MOTOR BUSH:-		Supply:-	
MAX TEMP:-	FAN SPEED:-			BELTS:-		Encl:-	
HANDING/MOTOR POSITION:-				CTR DIST:-		Frame:-	

# RHF FANS LTD

UNIT 2, FERROUS WAY  
GILCHRIST ROAD  
NORTHBANK IND. PARK  
IRLAM, MANCHESTER  
M44 5FS  
TEL:- 0161-776 6400  
FAX:- 0161-775 6566

ISSUE	DESCRIPTION	D.F.	D.F.	DATE
A	Initial Release			

TITLE  
BW 500  
No9 Monoblock Dual Drive  
RHF DRG. No. INV11NUGSTBF1HAL01