

**UK Seating System  
Fire Escape and Emergency Information**

**Compliance with BS 9999:2008  
Code of practice for fire safety in the design,  
management and use of buildings**

Prepared by  
Lancaster Business Centre, Meteor Business Park  
Cheltenham Road East, Staverton  
GL2 9QL

Tel: 01452 347830  
Fax: 01452 347620  
[www.entouragelive.com](http://www.entouragelive.com)

## Introduction

In the summer of 2008 The National Railway Museum played host to a unique and remarkable event – a spectacular stage production of E. Nesbit’s classic children’s book, *The Railway Children*. This adaptation, written by Mike Kenny, was produced in conjunction with the York Theatre Royal and after a sell out run and acclaimed reviews, returned in 2009.

In 2010 a consortium of West End Theatre producers acquired the rights in the production and subsequently brought it to London staging it at the former Eurostar Terminal in Waterloo Station where a 1,000 seat venue was built around the railway tracks with audiences seated on either side.

Following fourteen four star reviews and after winning a prestigious Olivier Award for “Best Entertainment” the production was hailed as London’s theatrical sell out event of the year and ran for 28 weeks. After closing for works to be carried out by Network Rail on the station, the production was remounted in June 2011 where it ran for a further 18 week sell out run eventually closing in January 2012 due to the announcement of the abolition of BRB and Network Rail repossessing the building. A second production was also mounted in Canada, at Toronto’s historic Roundhouse Park in 2011.

For the winter of 2014/15 the producers are creating a brand new venue at London’s King’s Cross to once again stage *The Railway Children*. The show takes place in a series of

The King’s Cross Theatre is a state-of-the-art temporary marquee structure, engineered and built by one of Europe’s leading temporary structure specialists – DeBoer UK. At 40metres long and 30metres wide, the biggest difference to any ‘standard’ tent is that there are no internal support beams – the clearspan nature of the structure means that there is 1,200sqm of uninterrupted space and meaning that there is not a bad seat in the house.

## Definitions

Seatway:	BS 9999:2008 – distance between adjacent rows of seats
Travel Distance:	actual distance a person needs to travel from any point within a building to the nearest storey exit, having regard to the layout of walls, partitions and fittings
Radial Gangway:	BS 9999:2008 – gangway at an angle to the rows of seating or a stepped gangway in tiered seating
Place of Relative Safety:	BS 9999:2008 – place in which there is no immediate danger, but in which there could be future danger, from the effects of fire
Place of Ultimate Safety:	BS 9999:2008 – place in which there is no immediate or future danger from fire or from the effects of fire

## Purpose

This document provides information about the seating arrangements within the auditorium area, specifically relating to the design and calculations relating to the seating system and exiting from the auditorium.

## Basic Premise

The document relates information from BS 9999:2008 - Code of practice for fire safety in the design,

management and use of buildings.

## Seating

D.1 BS 9999:2008 states that:

*“In theatres, cinemas and similar venues, escape routes should be designed so that in the event of a fire they are capable of enabling the occupants to evacuate the whole building”*

**Escape routes at The King’s Cross Theatre are designed so that they are capable of enabling the occupants to evacuate the whole building.**

D.2 Discharge from stairs and final exits

Section D.2 discusses the requirements if the escape routes exit into foyer areas OR exit routes from multiple auditoria exit into a foyer, additional protection provision should be put in place.

**Fire resistant corridors will be constructed offering 30 minute fire protection to those exiting the structure until they are at a place of ultimate safety.**

Where an escape route or routes from one or more tiers in a theatre, cinema or similar venue discharge into a foyer, the foyer should be enclosed with fire-resisting construction.

**The King’s Cross Theatre complies with this required**

D.3.1 Seating and Gangways

BS 9999:2008 states that:

*“Where gangways are provided at each end of the rows of seating, the number of seats in a row is relatively unimportant provided that travel distances are complied with and generous seatways are provided”*

**Attendees travel distance is at a maximum of 32m (compliant with standards) before they reach a place of relative safety. Therefore The King’s Cross Theatre complies with this required**

D.3.2 Seat layout and travel distances

The seatway is the space between the back of one row of seating and the front of the next row of seating. The seatway is the space that an audience member can use to access their seat. The seatway can be measured when either fixed seating or ‘tip-up’ seating is in place.

If fixed seating is used then the measurement is taken from the closest of the fixed points of the back of the first row, to the edge of the seat section on the row behind.

If 'tip-up' seating is used then the measurement is taken from the closest of the fixed points of the back of the first row, to the folded up, underside section of the seat on the row behind (see below).

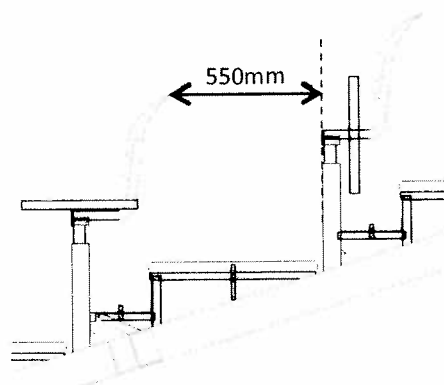

Section D.3.2 of BS 9999:2008 deals with the design and compliance of seating systems.

**It states that seatways should not be less than 300mm wide. The seating in The King's Cross Theatre Auditorium allows for a 550mm clear seatway, so complies with section D.3.2**

The seatway will determine the number of seats that are permissible in a row of seating. The larger the seatway, the greater the number of seats that can be in a row, before there is a requirement for a gangway.

Where seating opens only onto one gangway, the number of seats allowable effectively halves. **The King's Cross Theatre seating system does not contain any 'dead-end' rows; thus the maximum number of seats between gangways would be allowed.**

BS 9999:2008, section D.3.2 states that the number of seats in a row should be in accordance with Table D.1 (replicated below):

Seatway Width (mm)	Maximum number of seats in a row	
	Gangway on one side	Gangway on both sides
300 to 324	7	14
325 to 349	8	16
350 to 374	9	18
375 to 399	10	20
400 to 424	11	22
425 to 449	Not more than 12 seats if escape only possible in one direction	24
450 to 474		26
475 to 499		26
500 or more		Limited by travel distance
		All blocks

The table shows that for seating systems with a seat clearway of 500mm or more, the length of chair row is no longer the contributory factor when designing the seating system. Instead, the guidance allows for seating of over 500mm (commonly referred to as a 'boosted' clear seatway) to have increased row lengths, and bases the limiting factor on the travel distance to a 'place of safety'.

In this instance, a 'place of ultimate safety' is deemed to be any location outside of a temporary building or structure (although this can be within the fence line of the event).

**In all blocks the maximum number of seats permitted would be 26. The maximum row length in all blocks is 18 seats which is below the number permitted and therefore complies.**

### Seating type

There are six blocks of seating – each of which is made up of tiered seating in rows.

Block A – 13 rows tiered / 158 seats total

Block B – 13 rows tiered / 236 seats total

Block C – 13 rows tiered / 160 seats total

Block D – 13 rows tiered / 158 seats total

Block E – 13 rows tiered / 236 seats total

Block F – 13 rows tiered / 160 seats total

This gives a total of 976 seats and this means that the maximum number of guests in the auditorium at any one time is 1412.

### Gangways

Section D.3.3 states that gangways should conform to the following specific recommendations:

<p>a) Gangways should be not less than 1100 mm wide, unless used by not more than 60 persons in which case they should not be less than 900 mm wide.</p>	<p>The narrowest gangway is no narrower than 1100mm – <b>The King's Cross Theatre Auditorium system complies with this requirement.</b></p>
<p>b) There should be no projections which would diminish the clear width of the gangway, other than any handrails each intruding not more than 100 mm. If a handrail intrudes more than 100 mm into a gangway, for the purposes of calculating the capacity of the gangway the gangway width should be regarded</p>	<p>No handrails project into the calculated gangway routes – <b>The King's Cross Theatre Auditorium system complies with this requirement.</b></p>

<p>as reduced by the amount that the intrusion exceeds 100 mm. Central handrails with a width not exceeding 100 mm should be ignored when determining gangway width.</p>	
<p>c) The ends of all rows of seats should be so aligned as to maintain a uniform width throughout the length of a gangway, unless the escape flow would be in one direction only (i.e. access to any alternative means of escape is along the rows), in which case the gangway may widen towards the storey exit.</p>	<p>The ends of the rows of seats in The King's Cross Theatre Auditorium are aligned to maintain a uniform width throughout the length of the gangway as escape can flow in more than one direction – <b>The King's Cross Theatre Auditorium system complies with this requirement.</b></p>
<p>d) Where a gangway provides access to a wheelchair space, the escape route from that space should be suitable for wheelchair users (see BS 8300).</p>	<p>Multiple suitable means of escape have been provided for wheelchair users – <b>the Theatre in the Park Auditorium system complies with this requirement.</b></p>
<p>e) Storey exits provided within the body of a seating layout should be approached from the side by transverse gangways.</p>	<p>Exits from the seating system are approached from the side by transverse gangways – <b>this does not apply to the design of The King's Cross Theatre seating system and therefore complies.</b></p>
<p>f) Transverse and radial gangways in auditoria with tiered seating should not cross each other (i.e. any intersections should be "T" junctions). Connections between transverse and radial gangways should be offset to ensure a smooth flow to the exits.</p>	<p>Transverse and radial gangways within the Theatre in the Park Auditorium <b>do not</b> cross each other (i.e. all intersections are "T" junctions).</p> <p>Connections between transverse and radial gangways are offset to ensure a smooth flow to the exits – <b>this does not apply to the design of The King's Cross Theatre seating system and therefore complies.</b></p>
<p>g) In stepped tiers, the height of each step in a gangway should be not less than 100 mm and should not exceed 190 mm. Where there are two or more rises to each row of seats each step should be of equal height.</p>	<p>The height of the step in the gangway is 158mm. Where there are two or more rises to each row of seats each step is of equal height – <b>The King's Cross Theatre Auditorium system complies with this requirement.</b></p>
<p>h) The number of steppings in a tier uninterrupted by crossgangways should not exceed 40 if the rake exceeds 25degrees.</p>	<p><b>There are less than 40 steppings in a tier – The King's Cross Theatre Auditorium system complies with this requirement.</b></p>

<p>i) Where exits are approached from a stepped gangway, there should be a landing the width of the exit and at least 1100 mm deep immediately in front of the exit doors.</p>	<p>All landings are greater than the 1,100mm depth required – <b>this does not apply to the design of The King’s Cross Theatre seating system and therefore complies.</b></p>
<p>j) Stepped side gangways should be provided with a handrail fixed at a height of 840 mm measured vertically from the centre of the steps and projecting not more than 100 mm from the wall. If the gangway is at the side of a tier which does not extend up to a wall, the edge of the tier should be protected by a balustrade or guardrail to a height of not less than 1100 mm above the centre of the steps.</p>	<p>Stepped side gangways are provided with a handrail which is fixed at a height of 900mm in height above the height of the steps.</p> <p>The edge of each tier is protected by a guardrail which is minimum of 1,100mm in height above the height of the steps.</p> <p>This applies to the sides of gangways behind the back row of the seating – <b>The King’s Cross Theatre system complies with this requirement.</b></p>
<p>k) There should be no change of level between a seatway and the adjacent gangway. The gangway should not be stepped (or sloped with a differing slope) where the seatway meets the gangway. This does not preclude steps from the seatway to the gangway so long as handrails are provided. Any steps from a seatway should be at right angles to the line of travel along the seatway.</p>	<p>There is no change is level between any of the seatways and adjacent gangways – <b>The King’s Cross Theatre system complies with this requirement.</b></p>
<p>l) The nosings of stepped gangways should be made very conspicuous. This is particularly important in entertainment areas where light levels might be low. Markings using LEDs are particularly efficient.</p>	<p>Nosings of stepped gangways are highlighted with a high contrast colour (white on black) to aid visibility – <b>The King’s Cross Theatre system complies with this requirement.</b></p>

### Minimum Seating Space Per Person

Type of seating	Depth	Width
Backs provided	760mm	
Backs not provided	600mm	
Arms provided		500mm
Arms not provided		450mm
Wheelchair space	1400mm	900mm

The seating system at The King's Cross Theatre Auditorium provides sufficient space in accordance with the minimum requirements as laid down in Section C2.06. **The The King's Cross Theatre Auditorium provision gives a depth measurement of 820mm** from the rear of the occupied seat to the rear of the next forward seat.

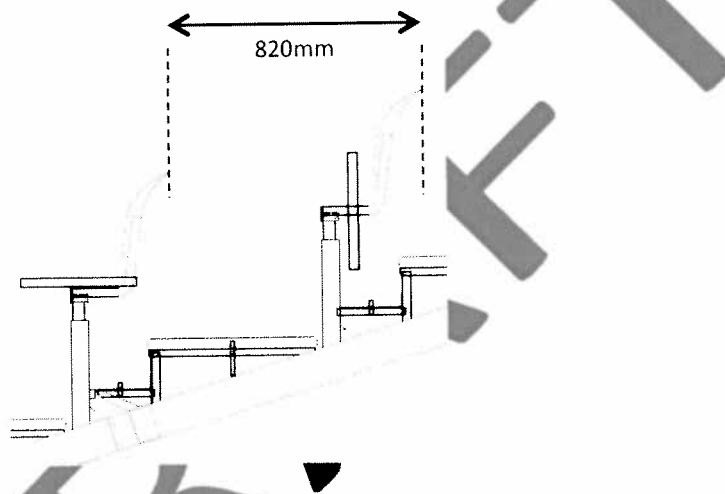

### Fixing of seats for closely graded audiences

All seating within The King's Cross Theatre Auditorium is securely located in position and checked daily. Seating cannot be removed easily and will not become displaced or overturned in the event of an evacuation. All chairs are firmly fixed to the 'floor', and the seating system is firmly fixed in place. It does not have the capability to retract or move. The King's Cross Theatre seating fits the definition from section D.3.4 for demountable seating: "This comprises tiered seating assembled from a kit of parts, and disassembled after use"

All seats, the seating system, all chairs and items are bolted or slotted together to provide one solid system – which will prevent seats from separating.

Access is available beneath all areas of the temporary tiered seating to clear accumulated rubbish. This is checked twice a day as part of the daily routine, managed by the site management team.

### Fire rating

The seating system, seating materials, drapes, set, furnishings, fabrics and decorative features will all be manufactured to, or treated to be fire retardant to the relevant British Standard as required.

This includes all venue drapes and carpeting used within the venues.



### **Stage Areas**

Due to the nature and layout of the venue (with the stage at the centre of the auditorium) it is very difficult to separate the audience space from the stage space. For this reason, close supervision is maintained of all stage activities. Many of the traditional stage requirements (safety curtain, proscenium wall) are not available in a venue of this nature, therefore additional fire protection equipment, training for staff and strict storage principles will be in place.

### **Dressing rooms**

All dressing rooms are located outside the auditorium venue within the backstage structure, which contains its own fire protection equipment. In addition all naked flames, candles and smoking are banned in all dressing rooms and greenroom areas.

### **Scene docks**

There is no scene dock within The King's Cross Theatre Auditorium.

### **Wheelchair provision**

It is possible for seating on the front row of the auditorium to be removed to provide space for wheelchair users. Seats will be removable in pairs to allow for sufficient space for a wheelchair user to feel comfortable.

The remainder of the proposed row can be left in place to allow for wheelchair users to sit alongside a companion should they so wish, who may or may not themselves require a wheelchair.

### **Evacuation time & fire exit capacities**

Escape times may be only a proportion of the total evacuation time in a structure and scenario such as The King's Cross Theatre Auditorium. The escape time is the time taken to move to a place of relative safety within the event boundaries, while the evacuation time is the time taken to empty the event site.

The information in this section is taken from the HM Government Fire Safety Risk Assessment for Open Air Events and Venues (the closest applicable guidance), and is derived from the guidance originally provided in the Guide Safety at Sports Grounds.

The maximum escape time for open-air events can vary greatly. The amount of acceptable time for the escape time from a venue depends on the risk that the event and venue pose to those in occupancy.

- Higher Risk: Less than 5 minutes**
- Normal Risk: Between 5 minutes and 10 minutes**
- Low Risk: More than 10 minutes**

Where the open-air event has a higher risk, escape routes should be based on an escape time of not more than 5 minutes. Where the open-air event has a lower fire risk, escape routes may be based on an escape time of up to 10 minutes.

Despite high levels of preparation, good previous data, excellent management experience and a good fire management strategy, it has been determined that 'higher risk' calculations will be used, with an overall theoretical target escape time of less than 5 minutes.

The capacity of an escape route is determined by the rate at which people pass along the route during each minute of the defined escape time. The following are suggested rates of passage for open-air parts of venues (HM Government Fire Safety Risk Assessment for Open Air Events and Venues, page 68):

- on all routes within seated accommodation (including gangways and ramps) and stairways – 73 people/metre/minute; and
- on all routes in other parts of the event or venue (including within standing accommodation) – 109 people/metre/minute.

The width and capacity of the escape routes required for the number of people present can be calculated by using the formula:

$$\text{Total exit width} = \frac{\text{number of people}}{\text{flow rate} \times \text{escape time}}$$

$$\text{Total exit width} = \frac{976}{73 \times 5}$$

$$\text{Total exit width} = \frac{976}{365}$$

= required 2.67m overall exit width.

In actuality there is a total of 7.20m of useable exit width from the auditorium area. This means that the theoretical escape time is actually:

$$\text{Total exit width} = \frac{\text{number of people}}{\text{flow rate} \times \text{escape time}}$$

$$7.2\text{m} = \frac{967}{73 \times \text{escape time}}$$

$$73 \times \text{escape time} \times 7.2\text{m} = 967$$

$$525 \times \text{escape time} = 967$$

escape time = 1.85 minutes which is approximately 1minute, 51 seconds

Its is however accepted and expected that it will actually take longer than this to completely clear the venue, but it is a good indication of the level of exiting available.