

Suite B4 Mindenhall Court High Street Stevenage Herts SG1 3UN
T: 01707 330711 E: randallarchitecture@gmail.com

Schedule of Proposed External Materials

**New Detached Dwelling
Land adjacent to 2 Willoughby Road, London NW3 1SB
Planning Approval Ref: 2009/5607/P**

Prepared by:

Randall Architecture
Suite B4
Mindenhall Court
High Street
Stevenage Old Town
Herts.
SG1 3UN

Client:

Neon (London) Ltd

Rev 3

Date: June 14

Proposed External Materials

The proposed external materials, as indicated on drawings no'd. 1058:P:110, 111, 112, 113, 120, 200 and 201 are as follows:

- Red facing brick to match adjacent properties
- Reconstituted stone sills and copings
- grey aluminium windows and doors
- timber main entrance door
- natural slate pitched roof covering
- lead flat roof covering
- white painted timber fascias, soffits and bargeboards
- black cast iron rainwater goods
- polished stainless steel entrance canopy

Typical illustrations of the proposed materials are shown below:

Aluminium Windows and Doors:



Reyners Aluminium 'Eco System' narrow profile thermally broken aluminium double glazed external doors and casement windows

Colour: RAL 7010 dark grey (powder coated)

Typical window illustrated against facing brickwork

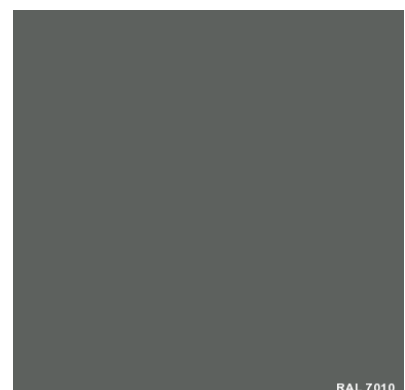
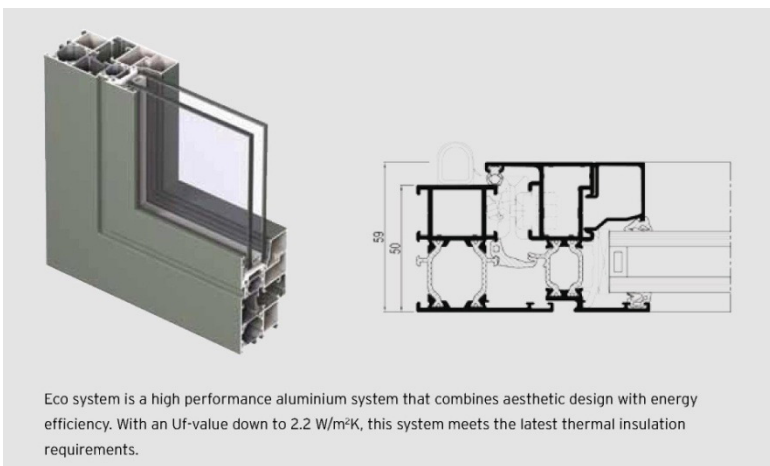



Thermally broken aluminium double glazed sliding patio doors to rear elevation

Colour: RAL 7010 dark grey (powder coated)

Typical doors illustrated against facing brickwork

Main Entrance door:



Grey painted hardwood entrance door and frame with full height glazed side light

Pitched roof covering:



Natural slate

Flat roof covering:



Lead flat roof covering with traditional roll joints

Juliette balcony:



Glass Juliette balcony with stainless steel handrail (to rear elevation).