

ALUMASC

RAINWATER SYSTEMS

Uniclass
L5294:P43
CI/SfB
(47) Xh4

April 2011

Skyline Architectural Fabrications

Fascias, Soffits & Copings



Maintaining a Flow of Information

www.alumascrainwater.co.uk

The Alumasc Rainwater website provides a wealth of information on all aspects of Aluminium Fascias, Soffits, Wall Copings and compatible rainwater systems. Also included are FAQs, file downloads for NBS specification clauses, installation information, a CAD library, stockist search and much more.

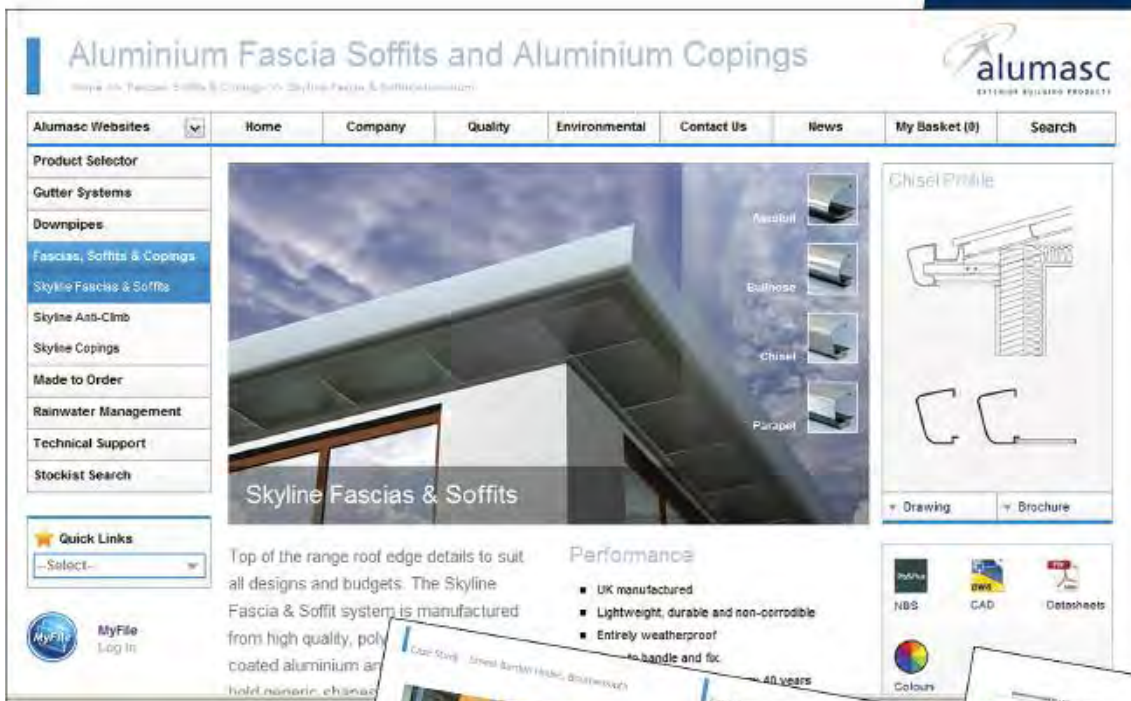

Technical Support

Alumasc Rainwater Systems are backed-up by comprehensive technical literature and by hands on project support starting with technical and design advice, and extending through site installation to recommendation of appropriate maintenance regimes. Implementation is led by the Alumasc Rainwater Manager appointed to the project.

Contents

Introduction

▪ Alumasc	4
▪ Quality and Sustainability	5
▪ The Benefits of Aluminium	6
▪ Aluminium Fascias, Soffits and Copings	7

Architectural Fabrications

▪ Alumasc Architectural Fabrications	8
▪ Polyester Powder Coating	9
▪ Introduction to Skyline	10
▪ Skyline Fascia Soffit Systems	11
▪ Skyline Standard Profiles	12
▪ Skyline Soffit Plank	13
▪ Skyline Designer Fascia Soffit Systems	14
▪ Skyline Coping System	16
▪ Skyline Anti-Climb Barrier	18

Case Studies

▪ Ernest Burden House, Bournemouth	20
▪ Smaralind Shopping Mall, Reykjavik	22
▪ London Road, Reigate	24
▪ Bartley Wood Business Park, Hook	25

Compatible Rainwater Products

▪ Aqualine Extruded Aluminium Gutters	26
▪ GX Pressed Aluminium Box Gutters	27
▪ Flushjoint Aluminium Downpipes	28
▪ Guardian Aluminium Security Downpipes	29

Alumasc Premium Products - All Brands	30
--	-----------

Proven Project Track Record - All Brands	31
---	-----------

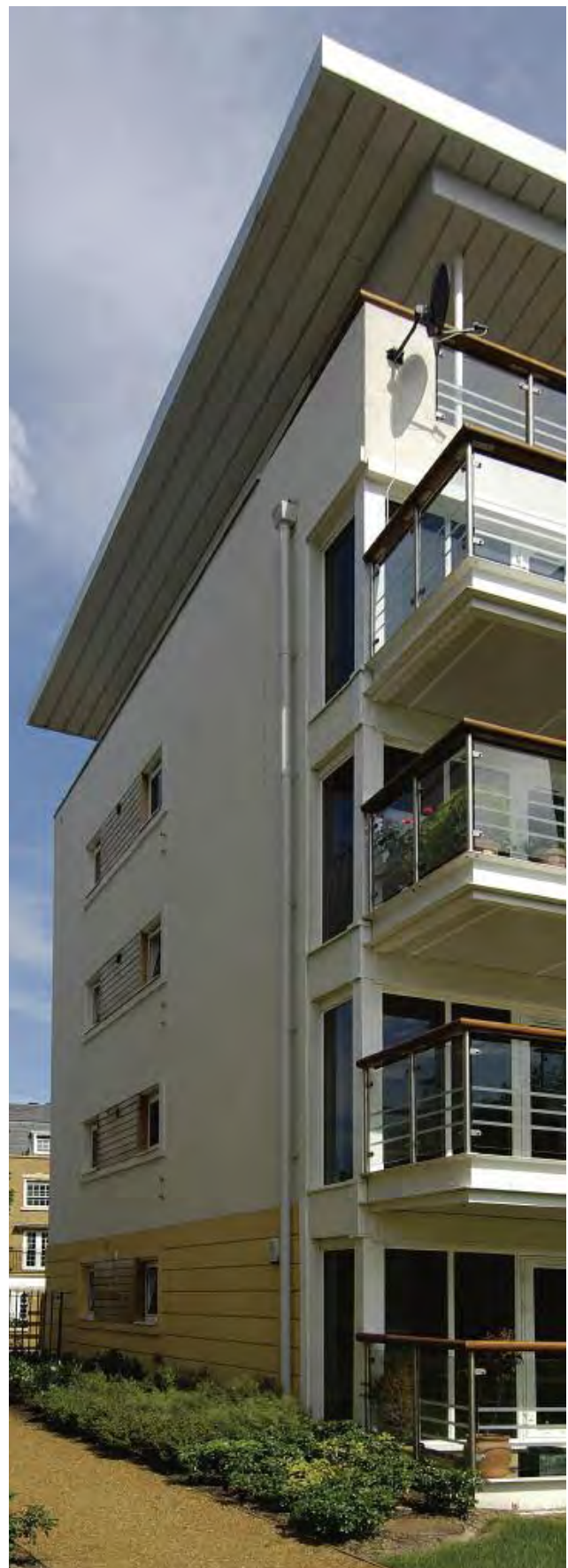

Alumasc - An Introduction

Alumasc Exterior Building Products is part of the Alumasc Group plc. The Group has over 800 employees, generating turnover in excess of £93 million. The aim is to focus on high quality, environmentally responsible building products within the construction arena in order to deliver first class customer service, long-term solutions and lasting relationships.

About Alumasc

Alumasc Exterior Building Products (Alumasc) is a leading supplier of high performance products and systems for specification. The Company has a proven track record in the UK construction industry accumulated over 60 years, during which time Alumasc products and systems have been used on some of Europe's most prestigious buildings.

Alumasc ensures a high quality of product specification and installation, delivering practical, engineered solutions. The Company's commitment to making ongoing improvements is demonstrated through its accreditation to the ISO 14001: 2004 Environmental Management Standard.

By pursuing sustainable building products, systems and manufacturing processes, Alumasc aims to offer specifiers a wide choice of design alternatives, with long-term peace of mind. Recognised brands such as Harmer, Apex, Derbigum, ZinCo, Hydrotech, Firestone and M.R., together with Alumasc's well-known architectural rainwater range have been independently certified, and in some cases have a lifespan in excess of 60 years or for the life of the building.

Alumasc brands are divided into distinct but interrelated groups:

- Rainwater
- Drainage
- Waterproofing
- Façades

Services and Support

Alumasc leads the way in the field of construction product and system manufacture and the delivery of proven solutions. This success is founded on four key areas:

Proven Products

A constantly evolving range of quality, world class products and systems, fully accredited to UK, European and North American Standards.

Technical Support

Comprehensive data for specification and use of all products and systems is available in published form, and on the company website. This is backed up by proactive project support, led by specialist area managers and using the latest CAD and calculation technology.

National Stockists

Alumasc products are available through a national network of stockists. This allows close control over all matters to ensure first class customer service.

Warranties

Alumasc products come with company-backed assurance as to their quality, life expectancy and suitability for purpose, ensuring long-term peace of mind for specifiers and end users.

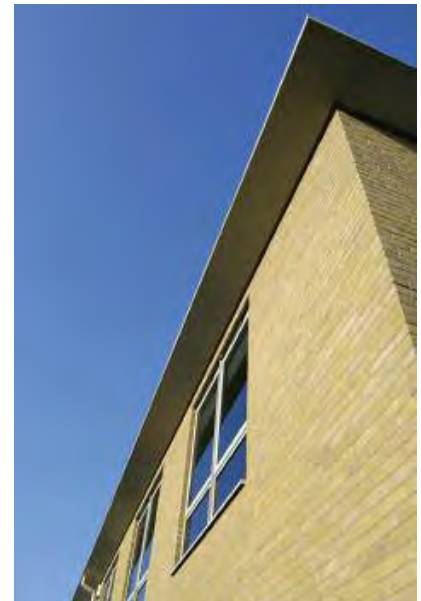

Quality and Sustainability

Alumasc has committed to a full spectrum of assessment procedures and quality control standards to monitor the manufacture and performance of its aluminium products. In addition to complying with environmental legislation, Alumasc is continuously developing its own measures to limit the adverse effects of its activities on the environment.

Quality

ISO 9001: 2008

Alumasc operates a quality management system which is independently audited to ISO 9001: 2008. The ISO 9001 framework governs the management of many aspects of Alumasc support services, manufacturing and transport operations. Alumasc extends quality management to its network of approved installers for single source accountability and peace of mind.



Sustainability

Alumasc actively pursues sustainability in the full range of products it offers and, with its partners and its suppliers, is committed to putting consideration for the built and wider environment at the core of all aspects of current business and future development.

ISO 14001: 2004

Alumasc's manufacturing sites at St Helens and Burton Latimer are audited to the ISO 14001:2004 Environmental Management Standard. Alumasc is committed to achieving improvements across all of its operating sites, not only as a good neighbour to the surroundings of manufacturing plants, but in the responsible sourcing of raw materials and monitoring of the impact on the environment as a whole.



BREEAM Standards

BREEAM points, as a framework for analysis and scoring, allow easy comparison of the relative merits of different construction types and also comparisons between different construction product groups. The BREEAM points system promotes the use of materials with a proven sustainable message and allows designers to differentiate between products with true ecological credentials and those not achieving the benchmark.

Indicative ratings for building materials given in the BRE Green Guide to Specification also allows designers to choose those products or construction methods that will be most beneficial in contributing to a high BREEAM points score.

Aluminium rainwater goods and fascia soffit systems are part of the range of high scoring Alumasc solutions. Promotion of these responsibly sourced materials brings clarity to the specification process thus achieving the desired effect of minimising the environmental impact of the construction process.



Testing and Certification

Applicable Standards

BS EN 485-2:1995

Aluminium and aluminium alloys - Sheet, strip and plate - Mechanical properties.

BS EN 755-1:1997

Aluminium and aluminium alloys - Extruded rod/bar, tube and profiles - Technical conditions for inspection and delivery.

BS EN 10147:2000

Continuously hot-dip zinc coated structural steels strip and sheet - Technical delivery conditions.

BS 5427-1:1996

Code of practice for the use of profiled sheet for roof and wall claddings on buildings - Design.

BS 476-3:2004

Fire tests on building materials and structures - Classification and method of test for external fire exposure to roofs.

BS 5250:2002

Code of practice for control of condensation in buildings.

BS 5925:1991

Code of practice for ventilation principles and designing for natural ventilation.

BS 6399-2:1997

Loading for buildings - Code of practice for wind loads.

BS EN ISO 10211-1:1996

Thermal bridges in building construction - Heat flows and surface temperatures - General calculation methods.

BS EN 1462:2004

Brackets for eaves gutters - Requirements and testing.

BS EN 12206-1:2004

Paints and varnishes - Coating of aluminium and aluminium alloys for architectural purposes.

British Board of Agrément

Certificate No. 86/1671

Alumasc Rainwater Systems.

The Benefits of Aluminium

Aluminium is a metal with exceptional characteristics, both in respect of its functional performance and sustainable credentials. It has become increasingly important in the Construction Industry and is being used in ever more innovative ways by designers and specifiers.

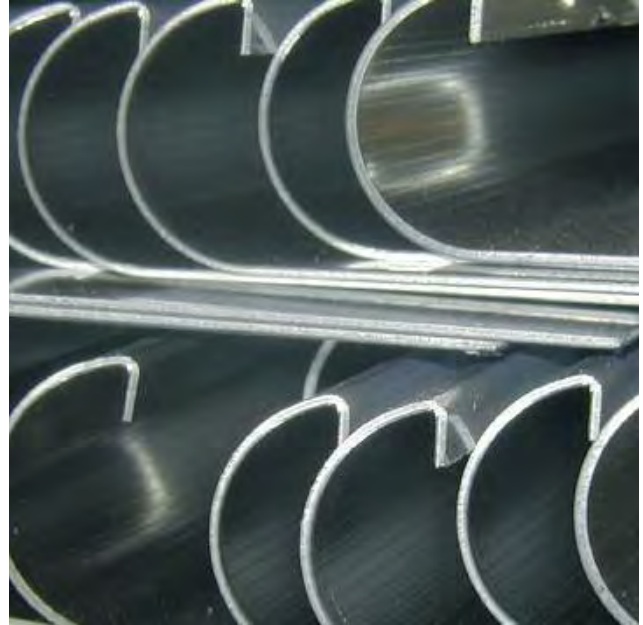

A 'Green Material'

To be deemed 'green', a material or product should be recyclable, sustainable and versatile. Aluminium has all of these properties and its production is strictly monitored for responsible sourcing of raw materials.

Aluminium has a light weight-to-strength ratio, which means it is strong yet economical. The reduced weight provides benefits in material transportation and application. Aluminium can also be formed in a variety of ways to accommodate off-site fabrication.

Durable and Strong

Aluminium is resistant to corrosion and does not rust. It is weather-proof and is unaffected by the effects of UV rays, ensuring optimal performance over its lifetime.

Mixed with small amounts of other metal to form an alloy, aluminium can provide the strength of steel at only one third of the weight.

Recyclable

Historically, aluminium has proven to be one of the most important materials in successful recycling programs. It offers a high scrap value, widespread consumer acceptance, and enjoys significant industry support.

Most aluminium products are made from 100% recycled scrap. The recycling process does not result in any loss of the materials' basic qualities and properties.

Recycled aluminium offers significant energy benefits as remelting used aluminium requires only 5 percent of the energy needed to produce primary metal. As aluminium can be recycled indefinitely it need never be disposed of in landfill.

Versatile

Aluminium and its alloys can be easily formed and shaped by rolling, extrusion, forging and casting, characteristics that reflect the wide choice of form and visual appearance of aluminium in construction applications.

The Benefits at a Glance

- Corrosion Resistant
- Lightweight
- Durable and Strong
- Formable
- High Strength to Weight Ratio
- Cryogenically Strong
- Electrically Conductive
- Non-combustible
- Non-magnetic
- Non-sparking
- Non-toxic
- Resilient
- Thermally Conductive
- Fully Recyclable

Aluminium Fascias, Soffits and Copings

Aluminium, with its unique properties, is the ideal material for creating high performance architectural roofing details of all designs and styles. Alumasc is the UK's leading manufacturer of BBA certified, polyester powder coated aluminium rainwater systems with a complete range of in-house manufactured standard and bespoke fascia and soffit systems.



Innovative

Aluminium is a young material, but has become the world's second most used metal after steel. It is known as 'the magic metal' because of its unique physical, chemical and mechanical properties which make it ideal for use in rainwater gutter and downpipe systems.

Design Flexibility

Aluminium can be formed in different ways to fulfil different functional purposes and create different visual effects. This allows great scope in the formation of architectural details, with appearance ranging from traditional to crisp and clean modern.

Lightweight

The lightweight characteristics of aluminium fascia and soffit products mean that they are economical and easy to transport. Consequently handling is easier and installation faster, with resultant cost effectiveness.

Life Expectancy

Alumasc aluminium fascia and soffit systems have a life expectancy in excess of 40 years in rural and suburban areas and up to 25 years in industrial and/or marine conditions.

This greatly enhances the product's cradle to grave embodied energy figure relative to systems (e.g. plastic) with shorter life spans. This also results in the removal of the appreciable costs, both environmental and monetary, of product replacement.

Ecological Benefits

Alumasc aluminium fascia and soffit goods contain no toxic substances and perform excellently when assessed from cradle to grave for effects on water quality (eutrophication) and water and ground contamination (ecotoxicity).

Low Maintenance

In service, Alumasc aluminium fascia and soffit systems are virtually maintenance-free. Apart from routine cleaning for visual reasons and special consideration for coastal areas, aluminium does not require any maintenance being carried out, providing a cost benefit over its lifetime.

Choice of Finish

Alumasc architectural fabrications offer a huge range of visual choice. The metal's natural protective coating of aluminium oxide gives a soft natural finish. An eye-catching choice of colours is available from Alumasc's BBA certificated Raincote range of powder coatings.

Alumasc Architectural Fabrications

Alumasc is one of the UK's foremost manufacturers of Aluminium products for the Construction Industry. Our expertise in Aluminium Architectural Fabrications stems from a proven project track record accumulated over 60 years, enabling us to provide unrivalled support for designers and specifiers.

Design

Alumasc offers a choice of standard and bespoke aluminium solutions to the specifier. The Alumasc team is able to give advice on schemes from the earliest inception sketches to allow even the most elaborate concepts to be realised. Involvement at these primary stages ensures optimum performance from the chosen materials whilst keeping a tight check on feasibility and cost of the design.

Solutions

Fascias and soffits can be designed as stand alone or to house integrated rainwater management systems. Alumasc can carry out rainwater flow calculations as well as making certain that all imposed loadings are catered for.

Alumasc's aluminium rainwater ranges include dry-joint extruded and wet-joint folded gutter profiles, which can be used in combination with various downpipes and roof edge treatments to fulfil different functional requirements (eg, high security) and for different visual effects to suit the building context.

Product Development

Alumasc routinely designs, manufactures and patents new products for the UK and world markets. Ongoing research and development ensures that our offer comprises high quality, world class products and systems that are fully accredited to UK and European standards.

Development of existing sound products and practices is central to the success of Alumasc, with new and innovative development grounded in the knowledge and experience Alumasc has of its core manufacturing materials.

Performance

Alumasc products are designed to give optimum performance over a prolonged period of time. This ethos has resulted in Alumasc being associated with innovative projects that have led the way in construction performance, standing the test of time as a testament to good design and detailing.

Fabrication

Alumasc's centrally located fabrication facilities employ both traditional and cutting edge production methods. All aspects of the operation are independently audited to ISO 9001 and ISO 14001 for quality and environmental management, maintaining the highest levels of accountability for both products and the conditions under which they are produced.

Materials

Alumasc has expertise in the selection and use of metals for construction products. A range of aluminium alloys is utilised throughout the Alumasc range. This ensures the correct material specification will be available for the most demanding of design criteria. Aluminium products can be supplied in a plain mill finish for on-site painting or in Alumasc's Raincote range of polyester powder coated finishes.

Delivery & Installation

Alumasc will optimise both delivery schedules and installation details to make on-site operations efficient and trouble free. Simple to follow instructions and layouts are available for every Alumasc scheme making on time project delivery, in the critical closing phases, a reality.

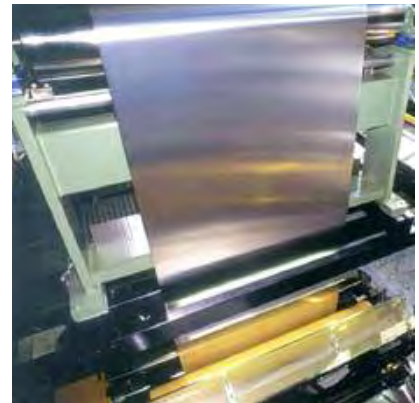

Polyester Powder Coating

Alumasc Aluminium Architectural Fabrications are available in plain mill finish for on site painting, or in the Raincote range of BBA approved, factory applied polyester powder coatings.

In-House Powder Coatings

Alumasc's in-house powder coating plant gives both the control and the freedom to produce a range of colour finishes to a level not typically available in the construction industry. Utilising the technologies and procedures adopted for its automotive precision castings division, Alumasc benefits from high specification coating techniques that fulfil the rigors of testing prescribed by some of the worlds leading vehicle producers. Finishes of this quality maintain their appearance even when subject to harsh geographical weather conditions.

The aluminium undergoes a series of pretreatments to provide the ideal prepared surface to receive an electrostatically applied polyester powder in the chosen colour. This is then 'baked' and bonded to the fitting in a carefully controlled oven; the complete process is achieved on a continuous line to obtain the best results. The performance of polyester powder coated rainwater systems greatly exceeds that of site painted systems.

Approvals & Quality Control

Polyester powder coating is in accordance with BS EN 12206-1:2004. This refers to the coating of aluminium and aluminium alloys for architectural purposes. In the case of rainwater systems it is accepted that such coating is both decorative and protective. Alumasc systems will certainly be finished to this standard, and will in most cases exceed it.

Along with independent auditing to the ISO 9001:2008 Quality Management and ISO 14001:2004 Environmental Management Standards, Alumasc maintains BBA certification for the powder coating of its aluminium rainwater goods in respect of longevity of performance and colour fastness - British Board of Agrément Certificate No. 86/1671.



Choice of Colour

The standard aluminium Raincote range comprises 16 colours with additional colours with a BS or RAL number available to special order, subject to quantity and cost.

The colours reproduced on this page are for general guidance only. Please contact Alumasc Technical Services for further information on colour choice and samples.



RAL 1011m Brown Beige

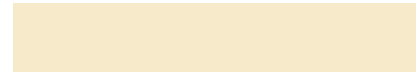

RAL 1013m Pearl White



RAL 1021m Cadmium Yellow



RAL 2002m Vermilion



RAL 3003m Ruby Red



RAL 3005m Wine Red



RAL 5003m Sapphire Blue



RAL 5010m Flower Blue



RAL 6005m Moss Green



RAL 6018m Yellow Green



RAL 7024m Graphite Grey



RAL 7038m Agate Grey



RAL 8017m Chocolate Brown



RAL 8019m Grey Brown

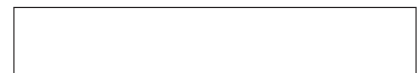

RAL 9016m White



RAL 9017m Black

Introduction to Skyline

The interface between walls and roof at the building eaves is one of the most crucial facets of design - both functionally and aesthetically. The sharpness and vibrancy of Alumasc's Skyline range of Fascias, Soffits and Copings provides dramatic engineered solutions over a wide range of buildings for both public and commercial sectors.

The Skyline Range

Skyline is a stylish and functional aluminium fascia, soffit and coping range offering solutions for use at roofing and gutter interfaces. Standard and fully bespoke designs from the Skyline range are available in high quality, in-house powder coated aluminium.

Skyline fascia and soffit components are designed to be used in conjunction with Alumasc's aluminium rainwater systems, in particular the GX range of folded aluminium gutters, providing a complete eaves and roof drainage solution.

Alumasc Technical Services can assist in the design of a fixing and support framework to suit individual project requirements. A design and fabrication service is also available for bespoke fascia profiles to suit special project requirements.

Skyline is not a rigid set of standard components, but a product rationale, developed to exploit the potential of Alumasc's wide ranging production capability in pressed and folded aluminium.



Skyline Fascias and Soffits

Skyline's range of four generic fascia profiles in aluminium, complemented by interlocking soffit planks, provides a wide choice of building eaves solutions.

Fascia profiles combine with soffit panels to create a range of fascia configurations which may be projected direct from the elevation or they may be combined with Alumasc soffit planks to produce varying eaves overhangs.

Skyline Copings

Skyline Copings provide an economical and easily installed capping to upstanding parapets, in conjunction with flat or pitched roofs. The strap fixing method avoids penetration of the capping, whilst allowing ventilation over the top of the wall. Skyline Copings are maintenance free, available in a wide range of colours and are equally suited to retrofit and new build projects.

Skyline Anti-Climb

Skyline Anti-Climb is designed with security in mind, preventing unauthorised access to the building roofscape. Skyline Anti-Climb barriers comprise support brackets and preformed curved barrier sections. They can be fitted in front of virtually any gutter profile, resulting in a bold architectural feature.



Skyline Fascia Soffit Systems

Skyline Fascias and Soffits offer top of the range roof edge details to suit all designs and budgets. Skyline systems are manufactured from high quality, polyester coated aluminium and are available in four bold generic shapes with bespoke designs available to order.

Applications

- Complete new build roof perimeter designs
- Combines with the standard soffit plank system
- Compatible with Alumasc's GX Box gutters, providing a combined eaves drainage solution
- Linear components joined by internal brackets, avoiding stepped joints
- Fabricated fittings are mitred, welded and have a smooth finish

Features and Performance

- Lightweight, durable and non-corrodible
- Entirely waterproof
- Easy to handle
- Life expectancy of aluminium : 40 years (rural/suburban areas); up to 25 years (industrial/marine areas)
- Aluminium is 100% recyclable

Colours & Finishes

- BBA approved polyester powder coatings
- In-house polyester powder coating facility
- 16 standard factory applied colours
- BS or RAL colours available to special order
- Also available in plain mill finish for on-site painting

Manufacture

- UK manufacture

Installation & Fixing

- Delivered to site in pre designed kit form
- Typical fixing can be carried out from the roof so no external access is required
- Project specific support brackets avoid on site modification
- Minimal maintenance required



Standard Skyline Profile Designs

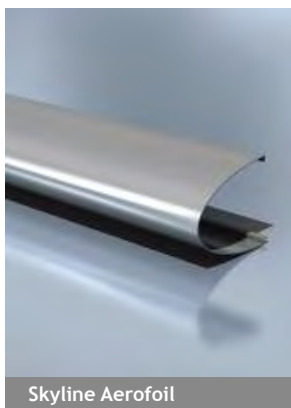

Skyline Aerofoil

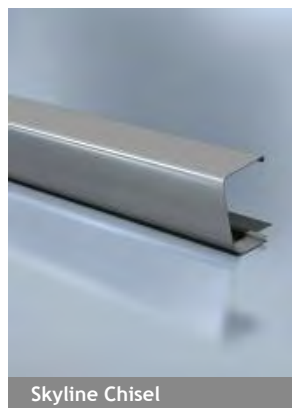

Skyline Chisel

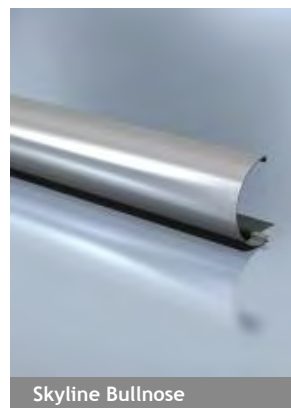

Skyline Bullnose

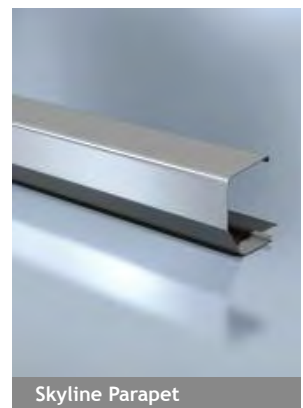





Skyline Parapet

Skyline Standard Profiles

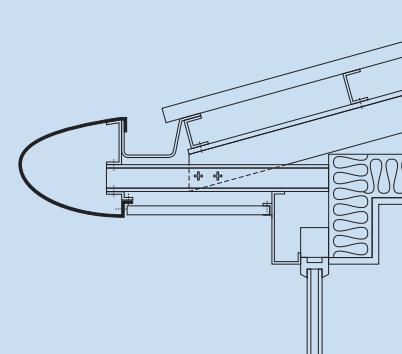
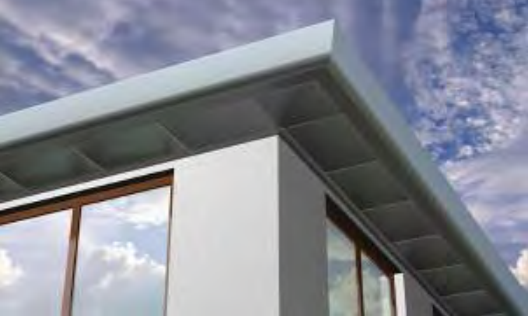
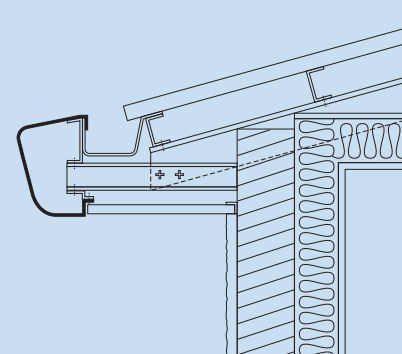
Skyline Fascias are available in a range of standard, readily available, profiles for simple and economic roof edge detailing.

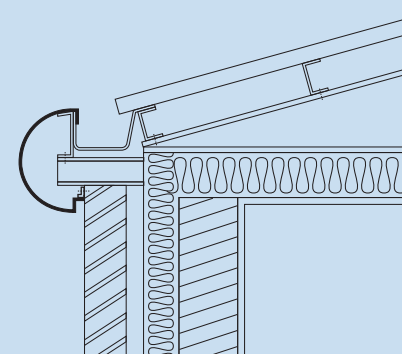
Standard Skyline Profile Designs

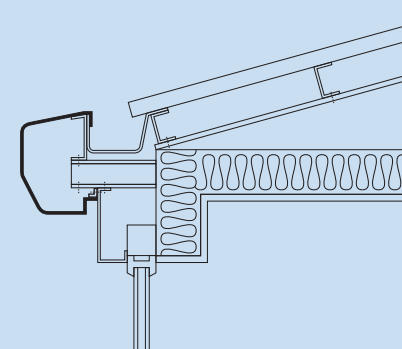
<p>Skyline Aerofoil</p> 		<ul style="list-style-type: none">■ Shown with projecting eaves and glazed facade with hidden GX gutter detail
<p>Skyline Chisel</p> 		<ul style="list-style-type: none">■ Shown with projecting eaves on render facade with hidden GX gutter detail
<p>Skyline Bullnose</p> 		<ul style="list-style-type: none">■ Shown projecting directly from brick facade with hidden GX gutter detail
<p>Skyline Parapet</p> 		<ul style="list-style-type: none">■ Shown projecting directly from render facade with hidden GX gutter detail

Skyline Soffit Plank

The Skyline Soffit Plank is a secret fix modular planking system designed to work on overhanging soffits and canopies or as part of a Skyline fascia scheme.



Skyline Soffit Plank Features:

- Available in variable widths from 150 to 600mm
- Individual plank lengths up to 4 metres
- Simple and quick to install
- Range of colours and finishes
- No visible fixings
- Deeper plank for longer spans
- Virtually maintenance free
- Lightweight, durable and corrosion resistant
- Lifespan of 40 years in rural and suburban conditions and up to 25 years in industrial and marine conditions
- Material thickness and fixing mechanism give excellent rigidity
- Aluminium is 100% recyclable
- Choice of standard, BBA approved polyester powder coated colours

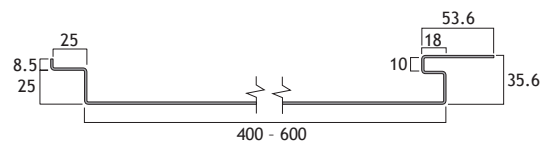
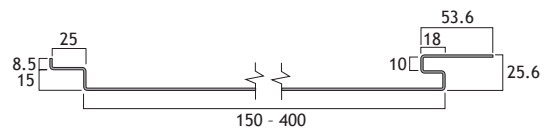
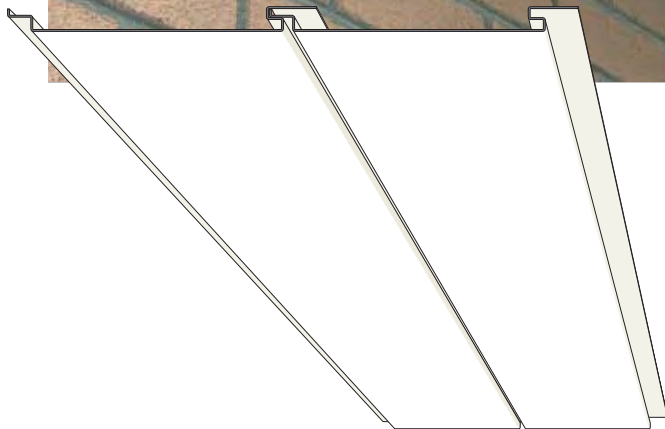

Skyline Soffit Plank with returned ends



Skyline Soffit Plank with open ends

Skyline Designer Fascia Soffits

Alumasc's Skyline Fascia and Soffit configurations offer top of the range roof edge details to suit all designs and budgets.

Skyline Designer Range

Skyline Designer is not a defined product range, but a collection of ideas which provide the architect with an opportunity to create highly distinctive fascias, soffit panels and cassettes that can be detailed and fabricated in a multitude of shapes and sizes to suit project requirements.

Alumasc Technical Support Services

Alumasc can offer advice from the first pencil sketches right up to site installation. Our in-house technical support team can advise at the outset what is physically possible with the materials selected and the choices made, in order to optimise designs and avoid unforeseen costs at order and installation stages.

Once the architectural details are agreed, full working drawings are produced with client approval required prior to fabrication. Alumasc will optimise both delivery schedules and installation details to ensure on-site operations are efficient and trouble-free. Simple to follow instructions and layouts are available for every Alumasc scheme making on time project delivery, in the critical closing phases, a reality.

With Alumasc Skyline the only limitation is imagination: if it can be made, we can make it.



Skyline Designer Fascia Systems

Our in-house-team of designers are available to offer advice from the first pencil sketches right up to site installation. Once the architectural details are agreed, full working drawings are produced with client approval requested prior to fabrication.

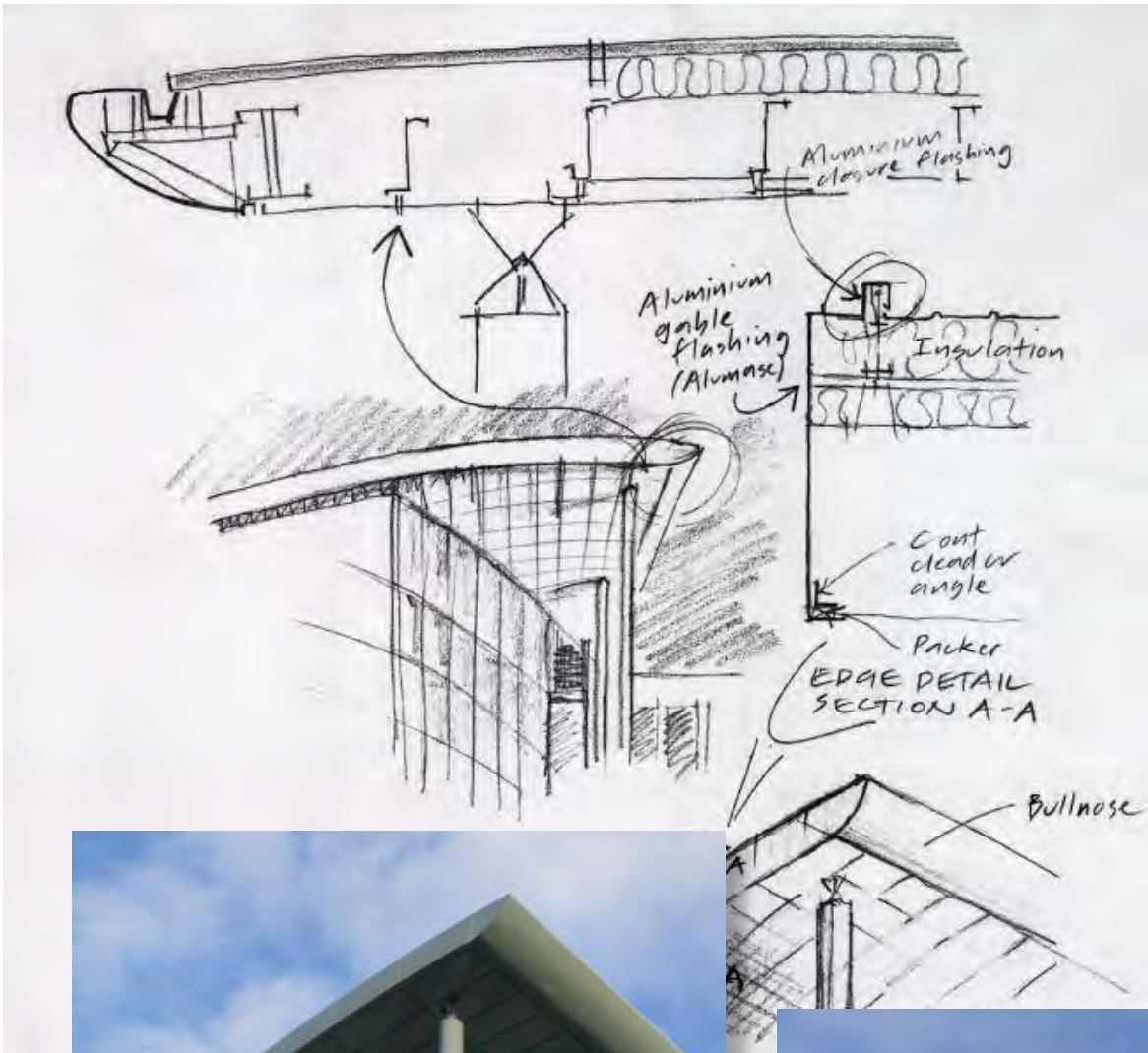

Skyline Coping System

The Skyline Coping system provides an economical and easily installed capping to upstand parapets, in conjunction with flat or pitched roofs. The strap fixing method avoids penetration of the capping, whilst allowing ventilation over the top of the wall. Skyline Copings are equally suited to retrofit and new build projects.

Applications

- Provides a totally weatherproof covering to upstand parapets as fixing method does not penetrate the Skyline Coping
- Suitable for new buildings and retrofit

Performance

- Attractive, clean lines are maintained as fixings are not visible on the surface of the Skyline Coping
- The fixing strap profile allows ventilation over the top of the wall whilst remaining weatherproof
- Material thickness and fixing mechanism gives excellent rigidity
- Lightweight, durable and non-corrodible
- Coefficient of linear thermal expansion is $23 \times 10^{-6} \text{mm/m/}^\circ\text{C}$
- A gap of 3-4mm should be left between Skyline Coping sections to accommodate thermal expansion
- Life expectancy of aluminium: 40 years (rural/suburban areas); up to 25 years (industrial/marine areas)
- Aluminium is 100% recyclable

Components and Manufacture

- UK manufactured
- Skyline Copings are fabricated from 2mm or 3mm thick aluminium alloy sheet, depending on width
- Fixing straps are pressed 3mm aluminium with extruded EPDM seals bonded to the top surface
- All fabricated fittings (90° corners, irregular corners, stop ends, closed ends, upstands, 90° tee junctions) are mitred, welded and have a smooth finish on the front face
- A waterproof membrane will be required beneath the Skyline Coping to provide an effective seal

Colours & Finishes

- In-house polyester powder coating facility with 16 BBA approved standard colours
- Additional BS or RAL colours available to special order; also available in plain mill finish for on-site painting

Installation & Fixing

- Simple and quick to install
- In most cases fixing can be carried out from the roof so no external access is required making it particularly suitable for renovation work
- Minimal maintenance requirements

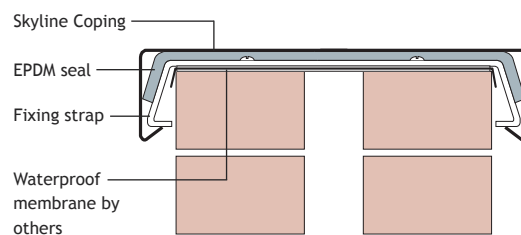

Skyline Coping System

Coping - 3 Metre Lengths

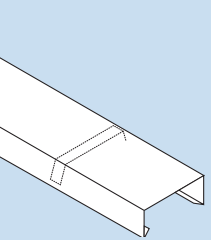

Intermediate support at 1500mm centres

Wall Thickness	Coping Width	Product Code
91-120	182	SL12/3M
121-180	242	SL18/3M
181-240	302	SL24/3M
241-300	362	SL30/3M
301-360	422	SL36/3M
361-420	482	SL42/3M
421-480	542	SL48/3M
481-540	602	SL54/3M
541-600	662	SL60/3M

Two fixing straps supplied

90° Angles

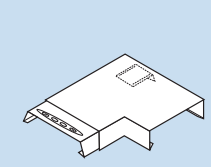

Wall Thickness	Coping Width	Product Code
91-120	182	SL12/90
121-180	242	SL18/90
181-240	302	SL24/90
241-300	362	SL30/90
301-360	422	SL36/90
361-420	482	SL42/90
421-480	542	SL48/90
481-540	602	SL54/90
541-600	662	SL60/90

One full and one half fixing strap supplied

Stopped or Closed Ends

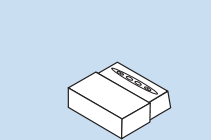

Wall Thickness	Coping Width	Product Code
91-120	182	SL12/CS
121-180	242	SL18/CS
181-240	302	SL24/CS
241-300	362	SL30/CS
301-360	422	SL36/CS
361-420	482	SL42/CS
421-480	542	SL48/CS
481-540	602	SL54/CS
541-600	662	SL60/CS

One fixing strap supplied

Straight Joint Reducers

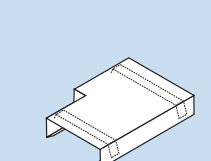

Wall Thickness	Coping Width	Product Code
91-120	182	SL12/SJ
121-180	242	SL18/SJ
181-240	302	SL24/SJ
241-300	362	SL30/SJ
301-360	422	SL36/SJ
361-420	482	SL42/SJ
421-480	542	SL48/SJ
481-540	602	SL54/SJ
541-600	662	SL60/SJ

Two fixing straps supplied for any two standard wall widths

90° Tee Junctions

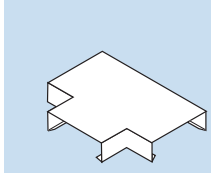

Wall Thickness	Coping Width	Product Code
91-120	182	SL12/TJ
121-180	242	SL18/TJ
181-240	302	SL24/TJ
241-300	362	SL30/TJ
301-360	422	SL36/TJ
361-420	482	SL42/TJ
421-480	542	SL48/TJ
481-540	602	SL54/TJ
541-600	662	SL60/TJ

Two fixing straps supplied

Stop End Upstands

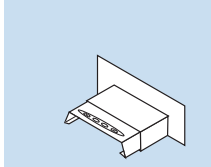

Full surround: also available on top face only

Wall Thickness	Coping Width	Product Code
91-120	182	SL12/US
121-180	242	SL18/US
181-240	302	SL24/US
241-300	362	SL30/US
301-360	422	SL36/US
361-420	482	SL42/US
421-480	542	SL48/US
481-540	602	SL54/US
541-600	662	SL60/US

One fixing strap supplied

Fixing Straps

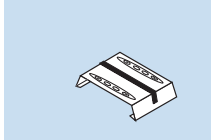

Wall Thickness	Coping Width	Product Code
91-120	182	SL12/FS
121-180	242	SL18/FS
181-240	302	SL24/FS
241-300	362	SL30/FS
301-360	422	SL36/FS
361-420	482	SL42/FS
421-480	542	SL48/FS
481-540	602	SL54/FS
541-600	662	SL60/FS

Notes:

All sizes indicated in the tables above are in millimeters. The wall thickness and Coping widths shown above are overall measurements. SL12 to SL36 Copings are manufactured from 2mm aluminium. SL42 to SL60 Copings are manufactured from 3mm aluminium.

Skyline Anti-Climb Barrier

The Skyline Anti-Climb Barrier is designed with security in mind, preventing unauthorised access to the roofscape. Robustly engineered and visually striking, this simply detailed system comprises support brackets and pre-formed curved barrier sections that can be fitted in front of virtually any gutter profile, providing a bold architectural feature.

Applications

- Provides maximum security in high risk areas
- Suitable for new buildings and retrofit
- Can be used with all types of Alumasc gutter systems

Performance

- Lightweight, durable and non-corrodible
- Entirely weatherproof and easy to handle and fix
- Coefficient of linear thermal expansion is $23 \times 10^{-6} \text{mm/m/}^\circ\text{C}$
- Where butt joints occur over an internal union bracing clip, a 2-3mm expansion gap must be provided between sections of the Anti-Climb Barrier
- All metal gutters should be cross bonded into Skyline Anti-Climb Barrier
- Life expectancy of aluminium: 40 years (rural/suburban areas); up to 25 years (industrial/marine areas)
- Aluminium is 100% recyclable

Components and Manufacture

- UK manufactured
- Two main components - support brackets and barrier sections
- Barrier sections are delivered to site preformed to shape, with loose union bracing clips
- Barriers are made from rolled 2mm heavy grade aluminium sheet to BS 1470: 1972 fixed to loose union bracing clips located at 625mm centres
- Brackets are made from 50mm x 6mm galvanised mild steel bar, bent and predrilled for fixing to the building fascia

Colours & Finishes

- In-house polyester powder coating facility with 16 BBA approved standard colours
- Additional BS or RAL colours available to special order; also available in plain mill finish for on-site painting

Installation & Fixing

- Simple to install. Contact Alumasc Technical Services for further information
- Minimal maintenance requirements

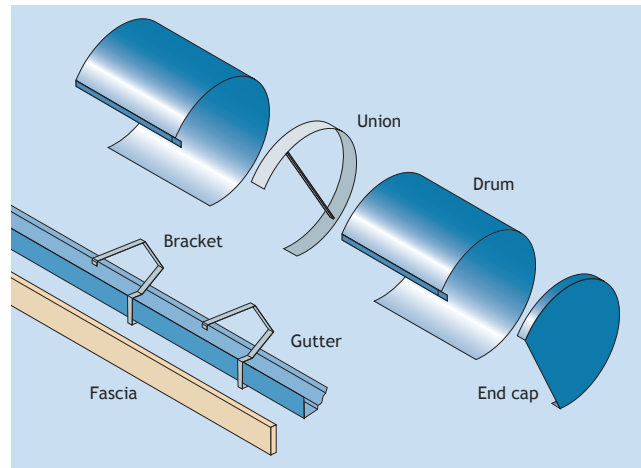

Skyline Anti-Climb Barrier

Bracket

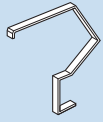
	Description	Product Code
	Galvanised brackets (625mm centres).	GALV/ZBKT

Union

	Description	Product Code
	Union is braced.	ACB/ZUNI

Drum

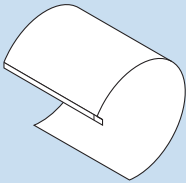
	Description	Product Code
	Supplied in 1.25 metre lengths. Make-up piece 625mm long required every 3.75m for maintenance access.	ACB/ZLTH

End Cap

	Description	Product Code
	Right Hand End Cap shown. Left Hand End Caps also available.	ACB/ZSND

Corner

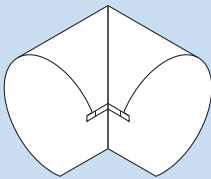
	Description	Product Code
	External Corner shown. Internal Corners also available.	ACB/ZANG

Typical Application - Pitched Roof

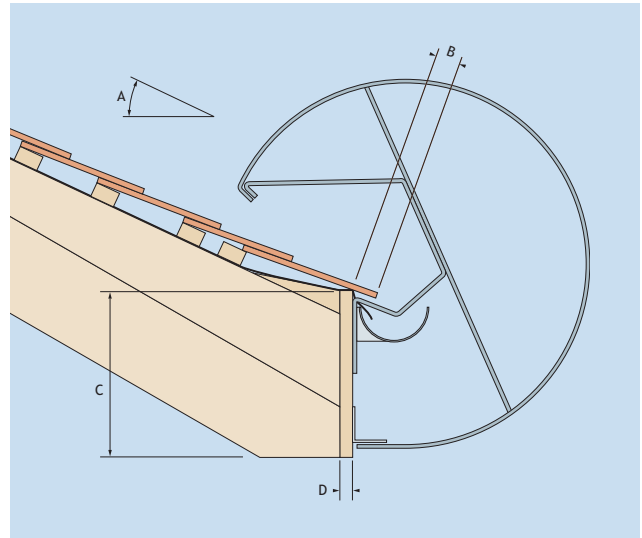

Typical Setting Out

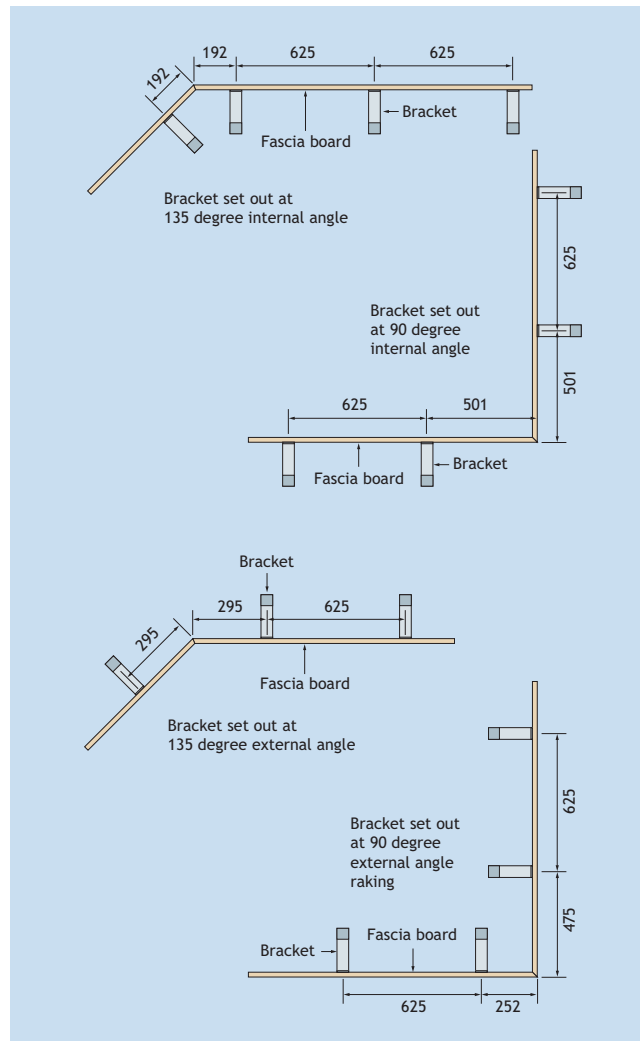

All gutter sections to be site drilled to suit galvanised bracket positions as required.

Case Study - Ernest Burden House, Bournemouth



Case Study - Ernest Burden House, Bournemouth

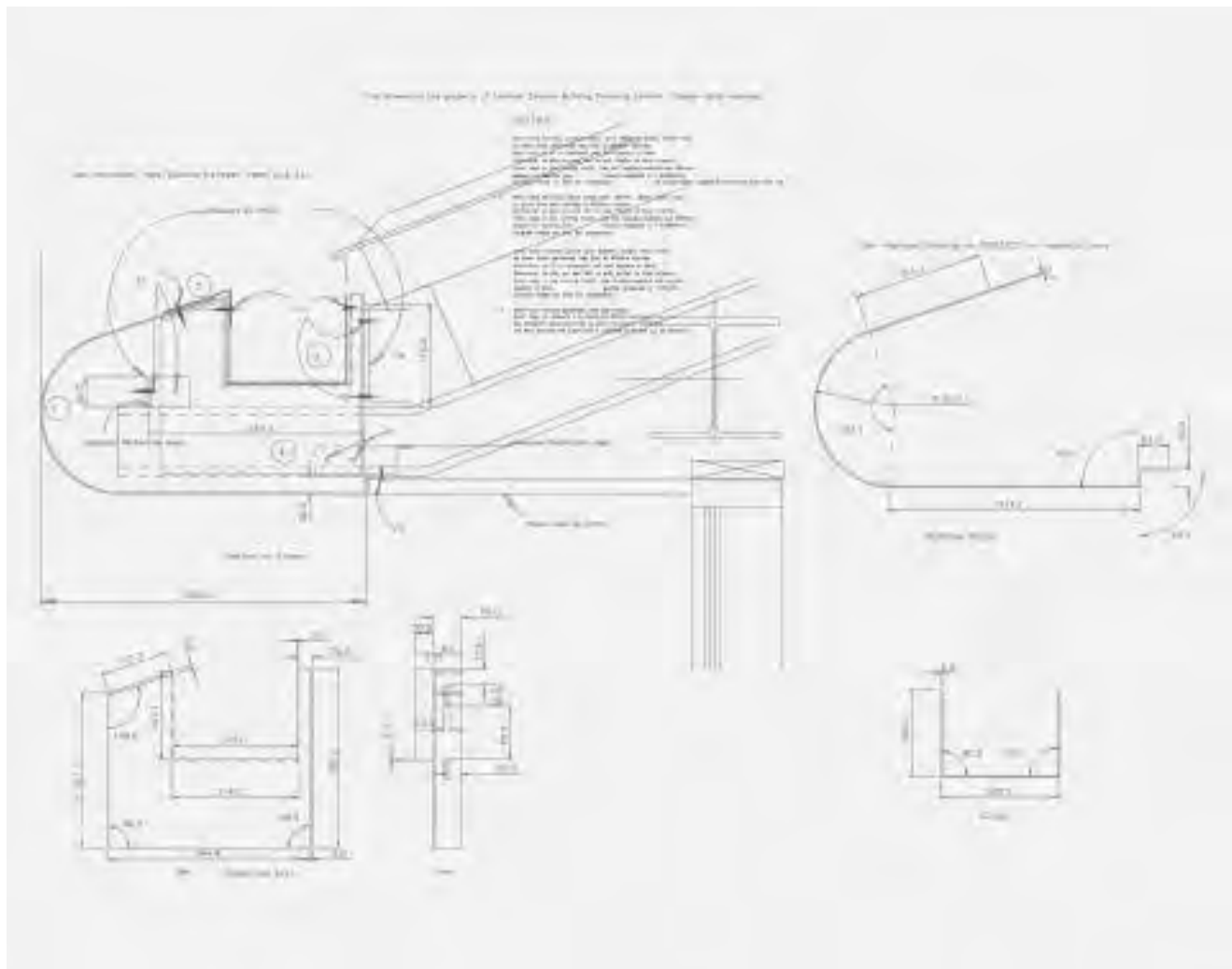

Case Study - Smaralind Shopping Mall, Reykjavik

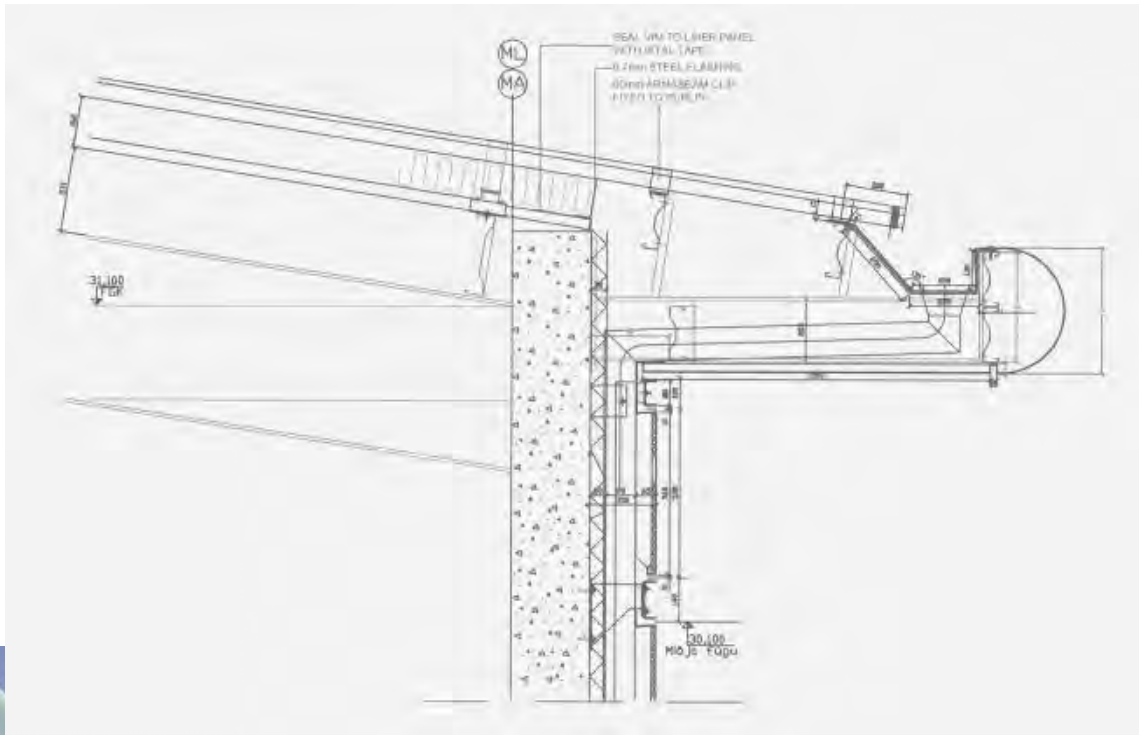

Case Study - London Road, Reigate

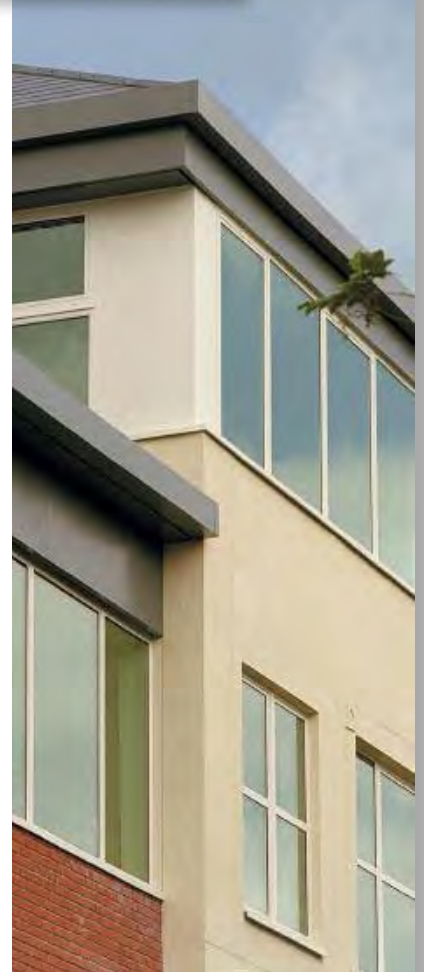
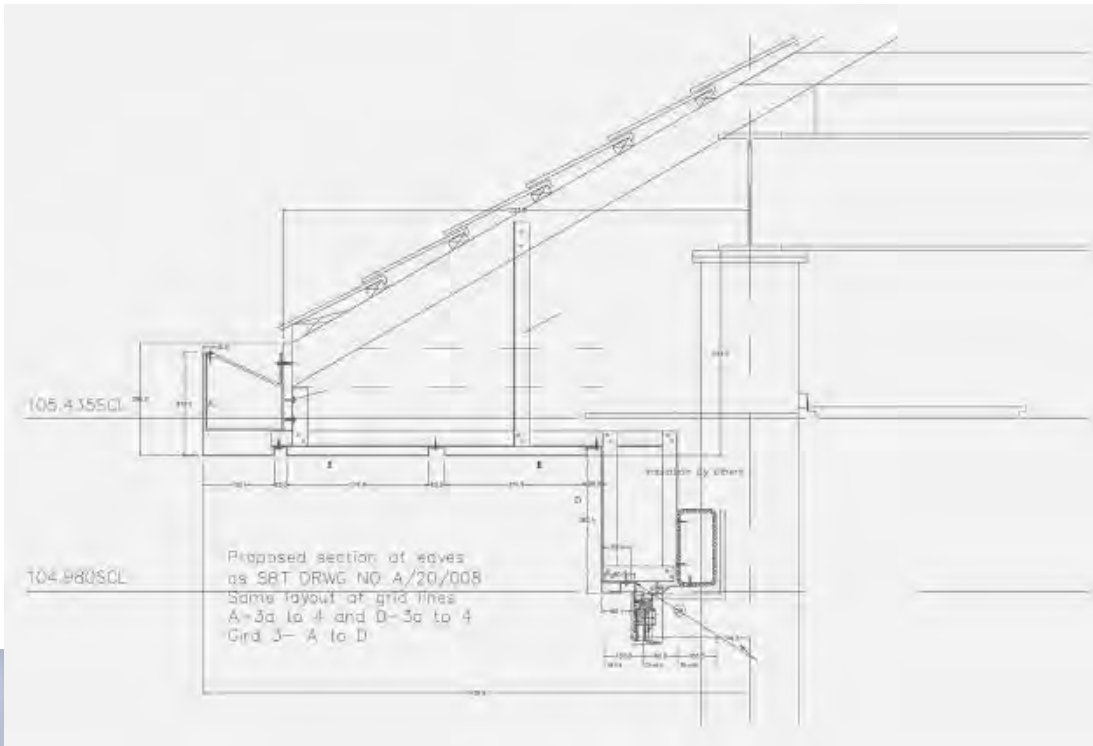

Case Study - Bartley Wood Business Park, Hook

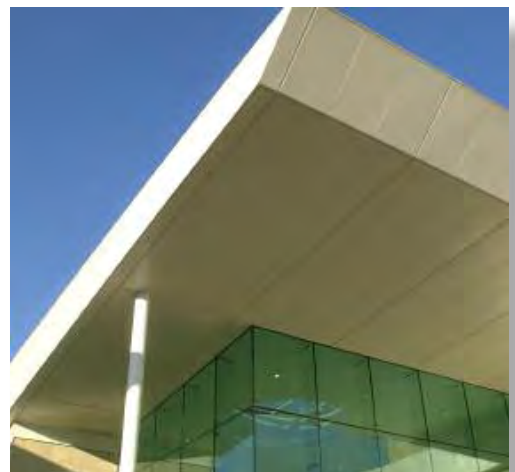
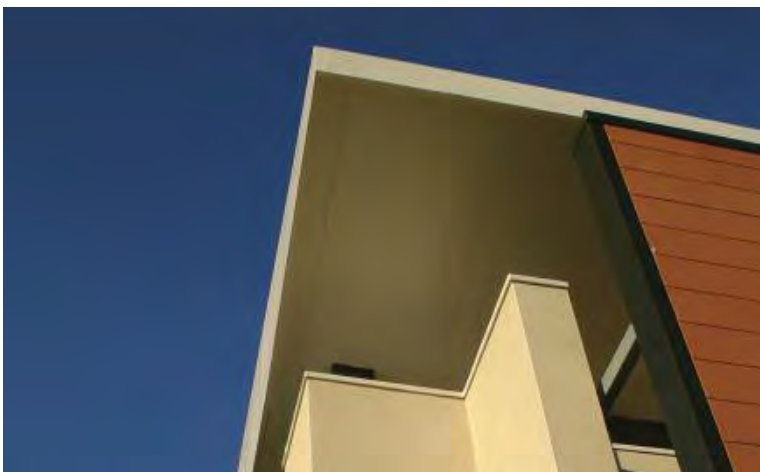
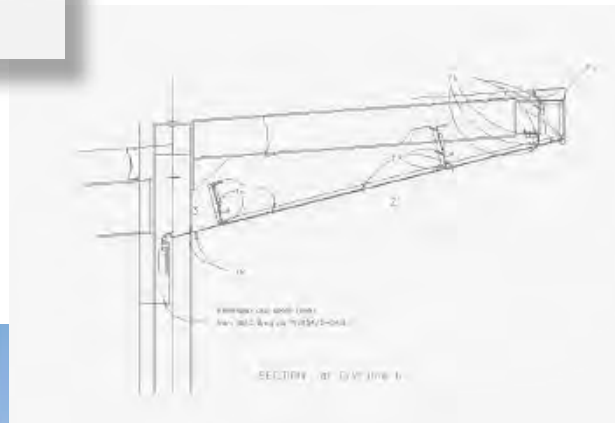
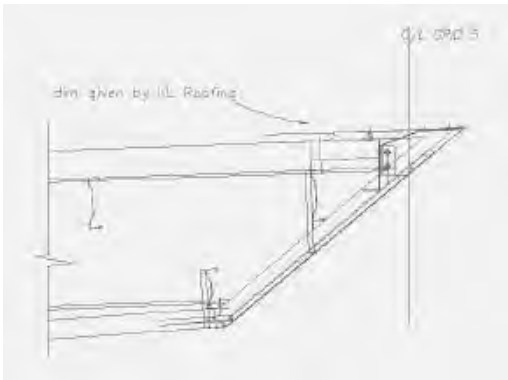

Aqualine Extruded Aluminium Gutters

Aqualine provides a compact and efficient rainwater system that significantly enhances and complements the appearance and architectural character of the building. A choice of 5 standard profiles is available with secret fix bracketry and all weather 'dry' jointing, with full provision for thermal movement.

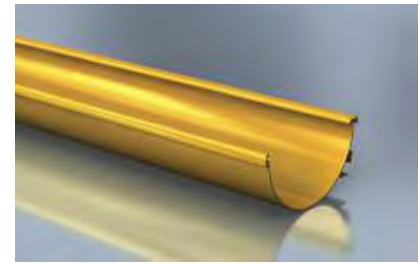
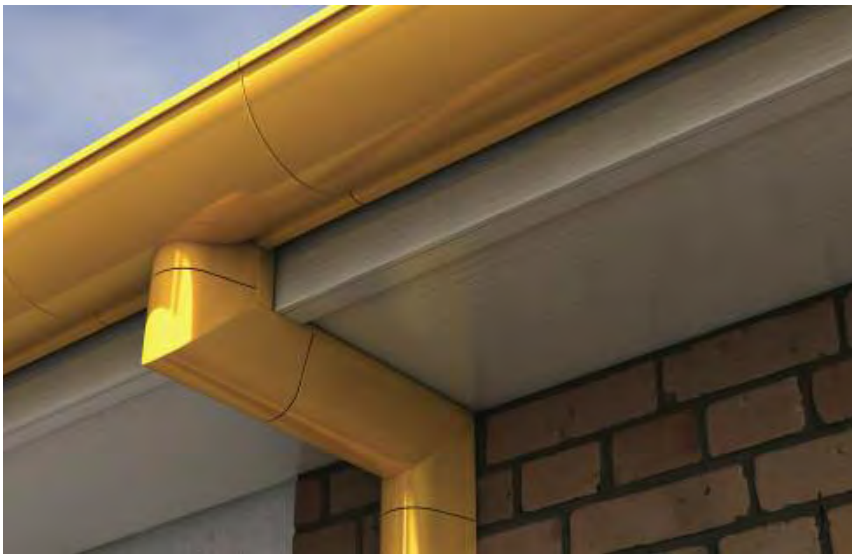

Half Round

3 sizes: 100x50, 120x60, 50x75mm

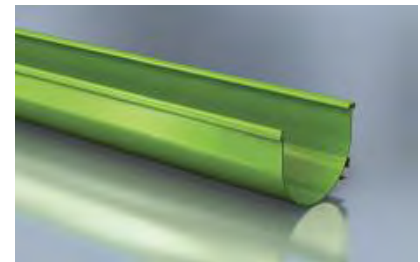

Deep Run

1 size: 110x85mm

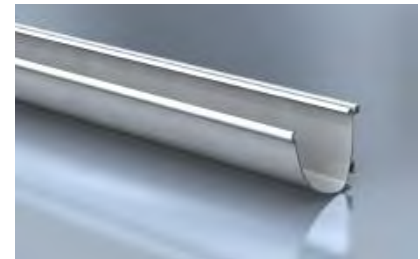

Modern

2 sizes: 100x85, 150x120mm

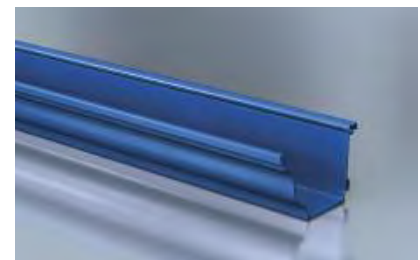

Moulded

2 sizes: 140x100, 160x100mm

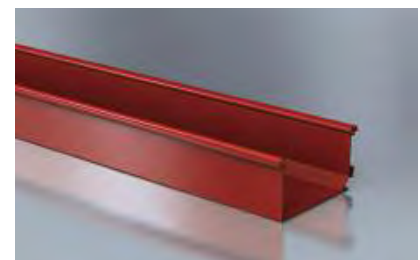

Box

3 sizes: 120x80, 140x100, 160x100mm

Applications

- Provides smooth lines and intricate detailing to contemporary designed buildings
- High flow capacity for enhanced performance
- Suited to both flush and projecting eaves applications

Features & Performance

- 5 gutter profiles available in 3 metre lengths, in a choice of sizes
- Designed to fully accommodate thermal movement at every joint
- Lightweight, durable and non-corrodible
- Life expectancy of aluminium: 40 years (rural/suburban areas); up to 25 years (industrial/marine areas)
- Easy to handle and fix
- Aqualine is patented and is also 'Design Registered'
- Aluminium is 100% recyclable

Colours & Finishes

- BBA approved polyester powder coatings, factory applied at Alumasc
- 16 standard colours with additional BS or RAL colours available to special order
- Also available in plain mill finish for on-site painting

Manufacture

- UK manufactured
- Based on aluminium extrusions to BS 1474: 1972, material 6063, T6

Installation & Fixing

- Concealed site fixing and jointing for a clean external appearance
- Once support brackets have been fixed to the building fabric all remaining assembly is by simple clip fix
- Joints are dry sealed using internal unions secured by sliding lock bars
- Minimal maintenance requirements

GX Pressed Aluminium Box Gutters

A robust and fully engineered box section gutter range designed for traditional wet jointing on site. GX is offered in three profiles in a choice of sizes and is especially suited to applications where maximum capacity gutters are required.

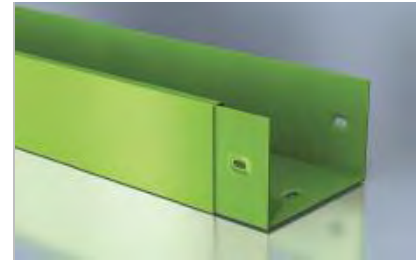
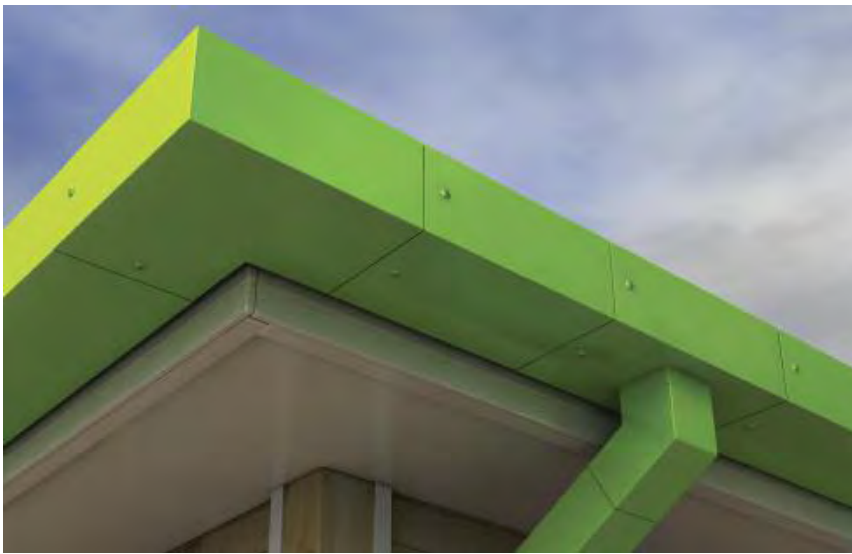

GX Joggle

5 sizes: 100x75, 125x100, 150x100, 150x150, 200x150mm

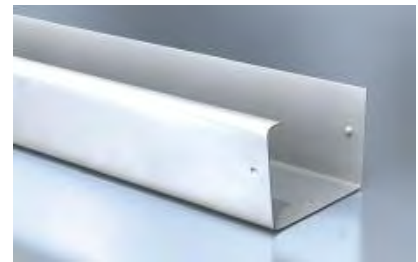

GX Smooth

5 sizes - 120x75, 140x100, 170x125, 175x150, 225x150mm

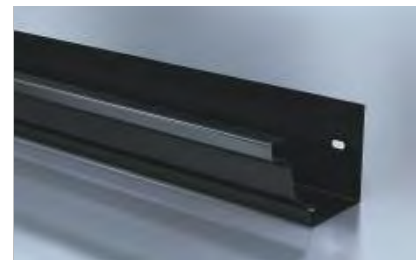

GX Moulded

5 sizes - 113x75, 140x100, 160x100, 175x150, 200x150mm

Applications

- High capacity gutters for traditional or modern buildings
- Fully compatible with Alumasc's Skyline fascia/soffit system
- Can provide an all aluminium eaves/soffit solution
- Gutters can be exposed or concealed

Features & Performance

- 3 gutter profiles available in 3 metre lengths, in a choice of sizes
- Designed to fully accommodate thermal movement at every joint
- Lightweight, durable and non-corrodible
- Life expectancy of aluminium: 40 years (rural/suburban areas); up to 25 years (industrial/marine areas)
- Easy to handle and fix
- BBA approved
- Aluminium is 100% recyclable

Colours & Finishes

- BBA approved polyester powder coatings, factory applied at Alumasc
- 16 standard colours with additional BS or RAL colours available to special order
- Also available in plain mill finish for on-site painting

Manufacture

- UK manufactured
- Gutter lengths, fittings and unions are pressed from various thicknesses of sheet aluminium (to BS EN 1462:1997, BS EN 612:1996 to BS EN 515:1993, BS EN 573:1995 and BS EN 485)

Installation & Fixing

- Wet sealed and bolted joints - a simple, well proven method
- Simple screw fixing with bracketry, generally concealed after fixing
- GX Joggle is supported by top straps
- GX Smooth is designed for simple jointing for a sleek appearance, including no requirement for sole support brackets and visible screw fixing
- GX Moulded is wet jointed and is fixed directly to the building fabric
- Minimal maintenance requirements

Flushjoint Aluminium Downpipes

A contemporary range of extruded aluminium downpipes. The Flushjoint system is based on concealed spigots which give a smooth, clean appearance that complements modern building design. The pipes are mounted on brackets to stand clear of the structure.



Round

4 sizes: 63, 75, 100, 150mm dia



Square

2 sizes - 75x75, 100x100mm

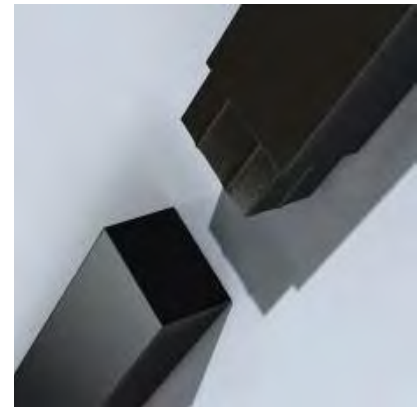

Rectangular

1 size - 100x75mm

Applications

- Contemporary pipework system suitable for new build and refurbishment projects
- Compatible with Heritage, Aqualine and GX gutter systems
- Flushjoint is not designed for use in underground drainage or as part of a soil or waste system

Features & Performance

- Choice of circular, square and rectangular pipes
- Hidden spigot jointing arrangement used to achieve completely smooth external appearance
- Material hardness and fixing mechanisms give excellent rigidity and high impact resistance
- Lightweight, durable and non-corrodible
- Life expectancy of aluminium: 40 years (rural/suburban areas); up to 25 years (industrial/marine areas)
- Easy to handle and fix
- Aluminium is 100% recyclable

Colours & Finishes

- BBA approved polyester powder coatings, factory applied at Alumasc
- 16 standard colours with additional BS or RAL colours available to special order
- Also available in plain mill finish for on-site painting

Manufacture

- UK manufactured
- Made from extruded aluminium to BS EN 12020:2001, BS EN 515:1993, BS EN 573:1995 and BS EN 755, from grade 6063 T6 alloy

Installation & Fixing

- Flushjoint pipework is built from the gutter downwards starting with the offsets and bends
- A choice of brackets are available to give varying projections
- Brackets secure pipework with minimum visual intrusion
- Minimal maintenance requirements

Guardian Aluminium Security Downpipes

A contemporary range of extruded aluminium downpipes designed for mounting flush with the building fabric. Guardian pipework has concealed brackets and concealed jointing which provides a high level of security.



Round

2 sizes - 86x106, 111x138mm



Square

2 sizes - 80x72, 109x102mm



Rectangular

1 size - 84x102mm

Applications

- Specifically designed for security conscious environments
- Suitable for new build and refurbishment projects
- Compatible with Heritage, Aqualine and GX gutter systems

Features & Performance

- Choice of circular, square and rectangular pipes
- Profiles fit flush to the wall making them vandal resistant and ungrippable
- Lightweight, durable and non-corrodible
- Life expectancy of aluminium: 40 years (rural/suburban areas); up to 25 years (industrial/marine areas)
- Easy to handle and fix
- Aluminium is 100% recyclable

Colours & Finishes

- BBA approved polyester powder coatings, factory applied at Alumasc
- 16 standard colours with additional BS or RAL colours available to special order
- Also available in plain mill finish for on-site painting

Manufacture

- UK manufactured
- Made from extruded aluminium to BS EN 12020:2001, BS EN 515:1993, BS EN 573:1995 and BS EN 755, from grade 6063 T6 alloy

Installation & Fixing

- Method of fixing allows pipes to be fitted into a recess in the facade
- Systems are assembled from the ground upwards connecting to running outlets
- Special drain connectors are available for connection to gullies
- Minimal maintenance requirements

Alumasc Premium Products - All Brands

Alumasc provides an unrivalled range of premium products for building exteriors and drainage, along with high levels of technical expertise and project support. Our wealth of experience combined with networks of approved installers, merchant stockists and a choice of warranty options ensures we provide appropriate product and system solutions for all types of buildings.



Alumasc is the UK's leading manufacturer of aluminium rainwater systems and offers a complete range of gutters, downpipes and fascia/soffits for both contemporary and traditional architecture.

Alumasc's cast iron rainwater system is for historic and restoration sites, with bespoke designs available to match or replace existing installations.

Rainwater

- Aluminium Rainwater Systems
- Aluminium Fascias, Soffits and Copings
- Cast Iron Rainwater Systems

www.alumascrainwater.co.uk

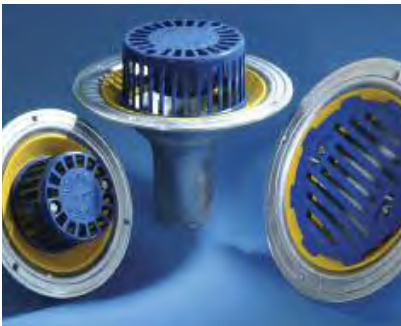

Alumasc's Harmer brand provides market leading solutions for rainwater handling and building drainage.

Aluminium roof, floor and shower drains are complemented by specialist drainage ranges in plastic. A choice of cast iron pipework systems is available for internal and rainwater drainage. Specialist rainwater management systems and paving and deck supports are also available.

Drainage

- Roof, Floor and Shower Drains
- Cast Iron Soil & Waste Systems
- Rainwater Management Systems
- Paving and Decking Supports

www.alumascdrainage.co.uk



Alumasc is a specialist provider of world class waterproofing and green roof systems.

The range includes Derbigum high performance flat roof membranes, Firestone TPO and EPDM single ply membranes, Hydrotech structural waterproofing and ZinCo Extensive, Biodiverse, Semi-intensive and Intensive green roofs.

Waterproofing

- Flat Roof Membranes
- Single Ply Membranes
- Structural Waterproofing
- Green Roof Systems

www.alumaswaterproofing.co.uk



Alumasc is a specialist in the design and development of thermally efficient insulated render systems. Alumasc's external wall insulation systems are available with a choice of insulating material and silicone, mineral or polymer-modified decorative render finishes.

Facades

- External Wall Insulation
- Render Only Systems
- Brick Slips & Specialist Systems
- Decorative Coatings

www.alumascfacades.co.uk

Alumasc Project Gallery - All Brands



Wimbledon Centre Court, Skyline



Burbo Point Apartments, Swisrail EWI



Centrium Apartments, Swistherm EWI



Derby Hospital, Harmer SML

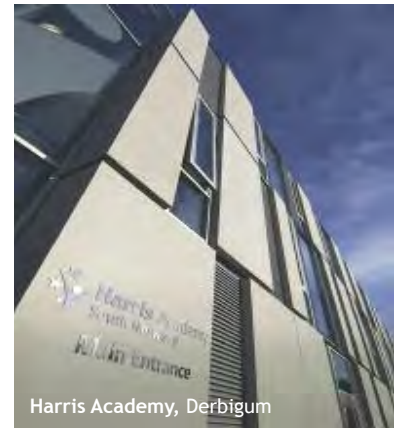

Harris Academy, Derbigum



Tate Modern, Hydrotech



Millennium Stadium, Harmer SML



Waterstone Park, Skyline & GX



River Quarter, ZinCo Green Roof; Hydrotech



St Pancras Station, Apex Heritage Cast Iron

ALUMASC

RAINWATER SYSTEMS

Rainwater

Drainage

Waterproofing

Façades

Technical Support

+44 (0) 1744 648400

Literature Hotline

+44 (0) 808 100 2008

Website

www.alumascrainwater.co.uk

ALUMASC EXTERIOR BUILDING PRODUCTS LTD

White House Works, Bold Road, Sutton,

St Helens, Merseyside, WA9 4JG

United Kingdom

Telephone: +44 (0)1744 648400

Facsimile: +44 (0)1744 648401

Website: www.alumascrainwater.co.uk

E-mail: info@alumasc-exteriors.co.uk



All reasonable care has been taken in the preparation of this brochure, all information, recommendations and guidance notes on the use of The Products are made without guarantee since the conditions of use are beyond the control of Alumasc Exterior Building Products Limited (The Company). The customer is responsible for ensuring that each product is fit for its intended purpose and that conditions for use are suitable. The information contained in this brochure and advice arising therefrom is free of charge and accordingly on the terms that no liability nor liability for negligence will attach to the Company or its servants in relation to any such service arising out of or in connection with this brochure. The Company pursues a policy of constant product development and information contained in this publication is therefore subject to change without notice.

0411/3K

The Alumasc logo, featuring a stylized figure holding a large umbrella, with the word 'alumasc' in lowercase and 'EXTERIOR BUILDING PRODUCTS' in uppercase below it.

alumasc
EXTERIOR BUILDING PRODUCTS