

Section A~A 1:50

Render [severely cracked - approximate locations indicated]

Cement flaunching
Brick

Render [severely cracked - approximate locations indicated]

Section B~B 1:50

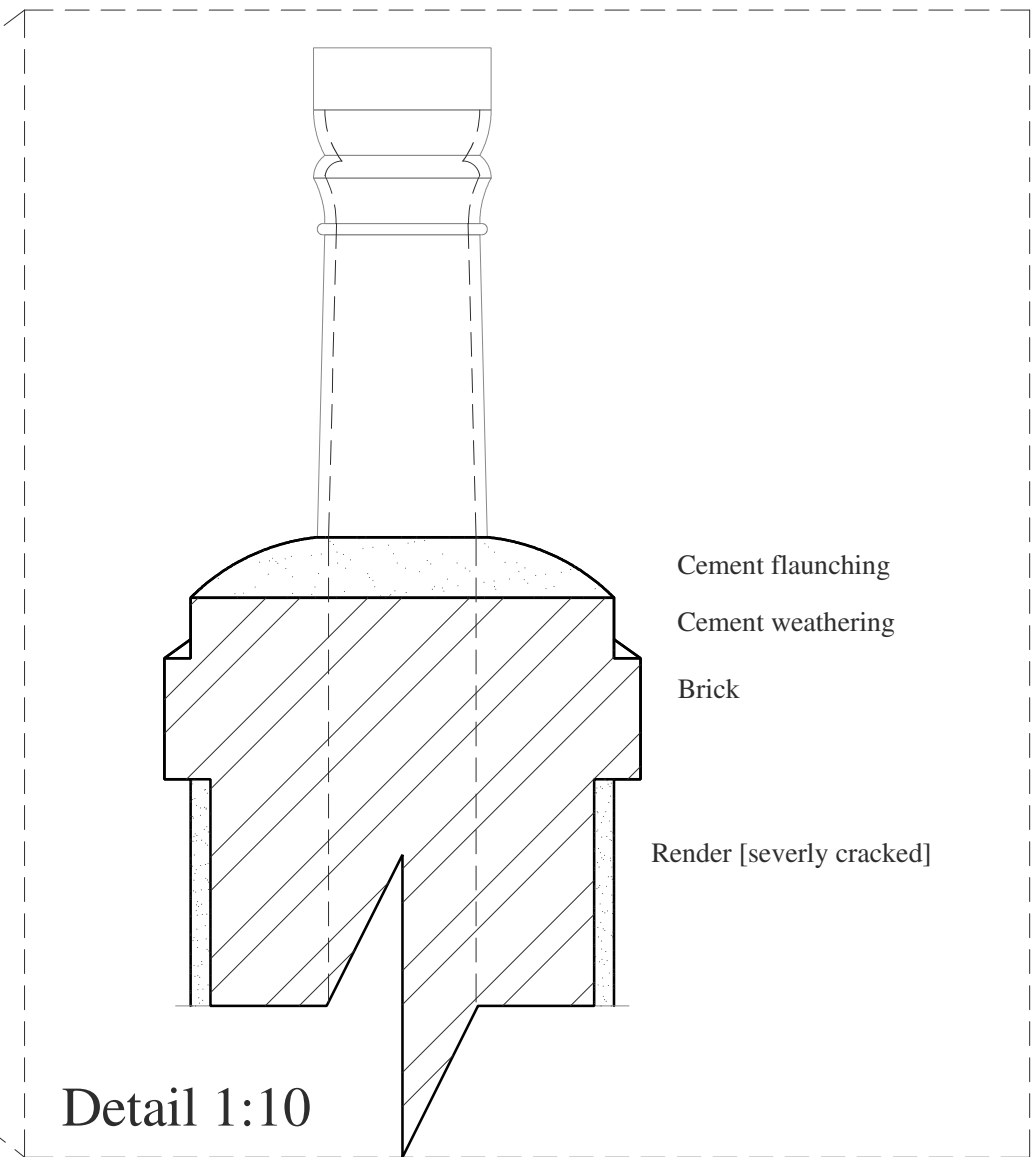
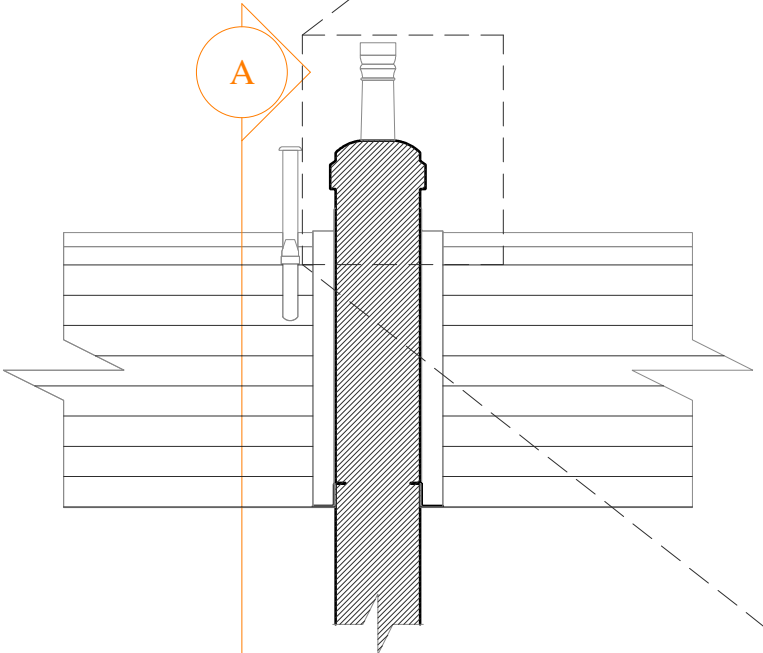

Detail 1:10

Third Floor +12.560



designer	dd.rmm.yy		
date	dd.mm.yy		
author	ag.unw.07		
checked by	ag.pep.08		
project	42 BELSIZE SQUARE		
status	EXISTING		
scale	A3		
drawing number	1407-GA-SE-01		
revision	-		

H and J architecture

32 Aqua Apartments
Goodchills Road
London
N4 2BP
t: +44 (0) 78 6267 6709
e: mail@hjarchitecture.co.uk

This drawing and design is for use solely in connection with the project described above. The drawing and design is the copyright of H and J architecture, and must not be reissued, loaned or copied without written consent. All dimensions and setting out to be checked on site before construction. Do not scale from this drawing. The drawing is to be read in conjunction with all other information relevant to the project. Any apparent discrepancy to be brought to the attention of the architect.