

NOTES:  
 1. THIS DRAWING NOT TO BE SCALED. FIGURED DIMENSIONS ONLY TO BE TAKEN.  
 2. SHOULD ANY DISCREPANCIES BE FOUND WITH THIS DRAWING, PLEASE INFORM THIS OFFICE.  
 3. COPYRIGHT OF THIS DRAWING IS OWNED BY J.MARCHITECTS.  
 4. THIS DRAWING SHOULD BE READ IN CONJUNCTION WITH THE PROJECT HEALTH & SAFETY FILE AND ANY TASK BASED METHOD STATEMENTS

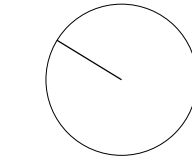
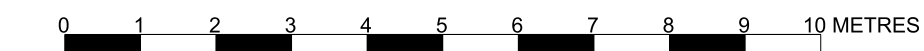
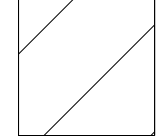
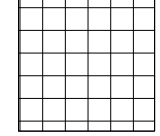
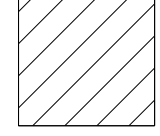
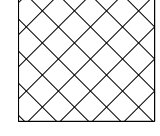

-  Suspended Floor
-  Ceramic Tiles
-  Hardwood Floor
-  Carpet

REV.	DESCRIPTION	DATE	DRN BY	CHK BY

**jmachitects**

PROJECT			
Heals Refurbishment Phase 2			
TITLE			
Fourth Floor - Proposed Floor Finishes			
CLIENT			
Threadneedle Property Investments Ltd			
JOB No.	DRAWING No.	REVISION	
5354	P(00)134	/	
SCALE	DRAWN BY	CHECKED BY	
1:200 @ A3	AM	MB	
STATUS	DATE	DATE	
PLANNING	14/06/14		

2nd Floor  
 Threeways House  
 40-44 Clapstone Street  
 London  
 W1W 5DW  
 T: 0207 580 5330  
 F: 0207 436 5348  
 Ion@jmachitects.net  
 www.jmachitects.net