

SECOND FLOOR PLAN
AS EXISTING 1 : 50

02.09.14 LISTED BUILDING		-
DATE	DESCRIPTION	REV
PROJECT		
21 PRINCE ALBERT ROAD LONDON NW1 7ST		
DRAWING		
SECOND FLOOR PLAN AS EXISTING		
SCALE	1:50 @ A3	DATE JUNE 2014
DRAWING NO.		
335.S204(-)		
neal tuson architects chartered architects & designers 11 Blackheath Village Blackheath London SE3 9LA t 020 8318 5222 e info@ntarch.co.uk © neal tuson architects		



REAR ELEVATION
AS EXISTING 1 : 100



02.09.14	LISTED BUILDING	A
25.08.14	INFORMATION	-
DATE	DESCRIPTION	REV
PROJECT		
21 PRINCE ALBERT ROAD LONDON NW1 7ST		
DRAWING		
REAR ELEVATION AS EXISTING		
SCALE	1:100 @ A3	DATE AUGUST 2014
DRAWING NO.		
335.S211(A)		
neal tuson architects chartered architects & designers 11 Blackheath Village Blackheath London SE3 9LA t 020 8318 5222 e info@ntarch.co.uk		
© neal tuson architects		



REAR ELEVATION (SECOND FLOOR) 1 : 20

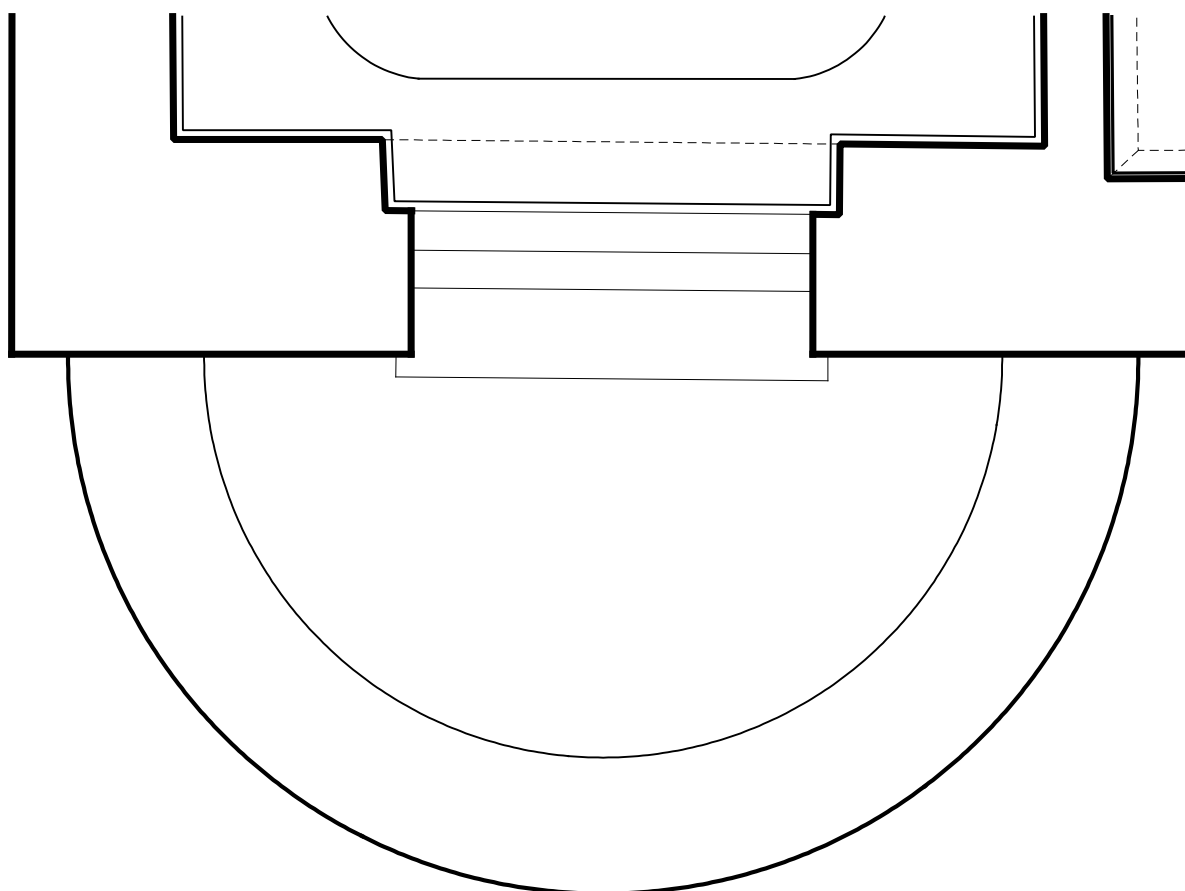

PART PLAN (SECOND FLOOR) 1 : 20



02.09.14	LISTED BUILDING	A
25.08.14	INFORMATION	-
DATE	DESCRIPTION	REV
PROJECT		
21 PRINCE ALBERT ROAD LONDON NW1 7ST		
DRAWING		
REAR BALCONY AS EXISTING		
SCALE	1:20 @ A3	DATE AUGUST 2014
DRAWING NO.		
335.S212(A)		
neal tuson architects chartered architects & designers 11 Blackheath Village Blackheath London SE3 9LA t 020 8318 5222 e info@ntarch.co.uk		
		© neal tuson architects