

Image 1
Indicative location of lateral connection



Image 2
Indicative location of lateral connection

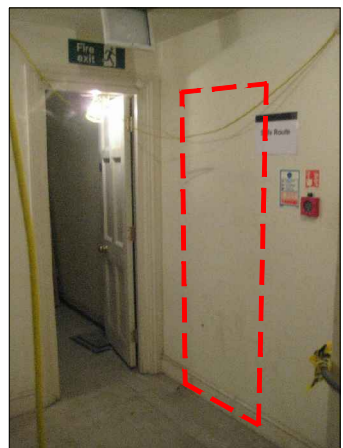
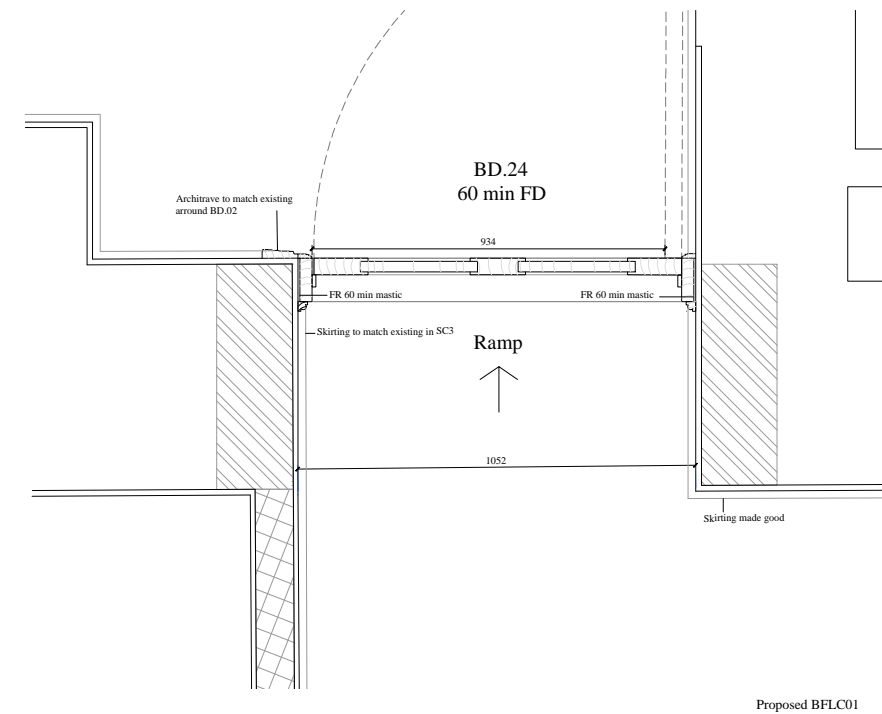
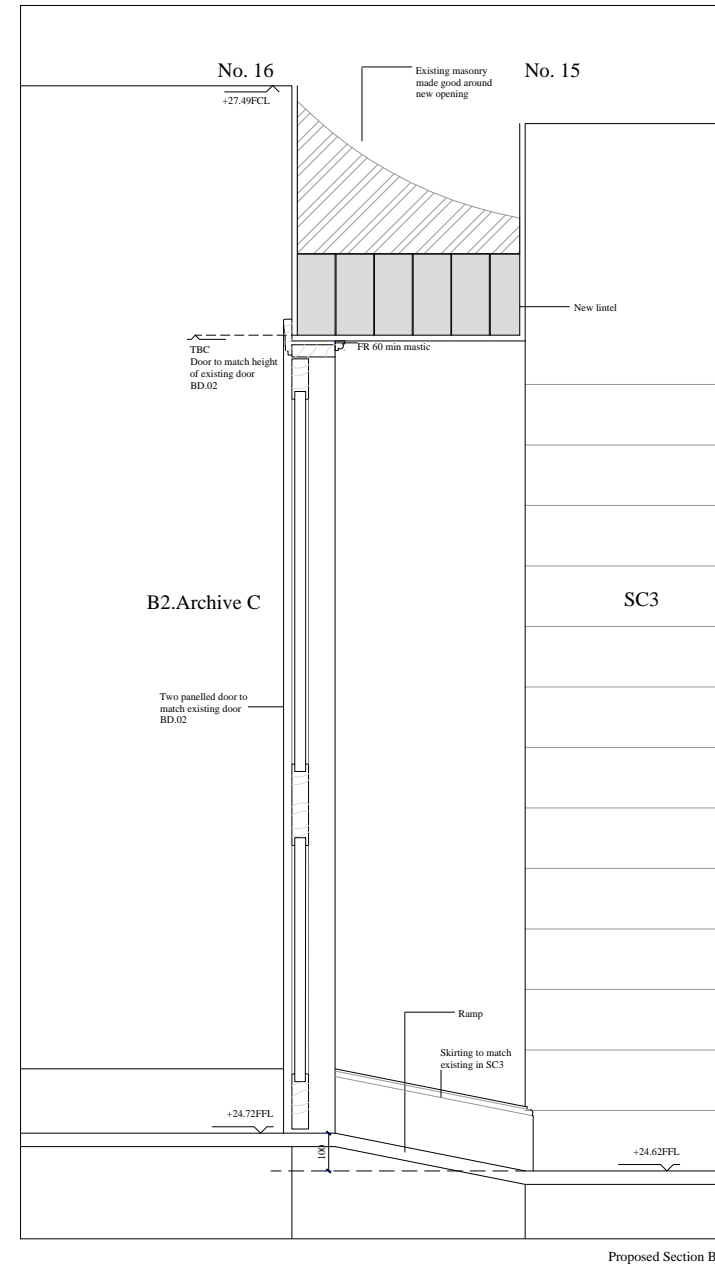
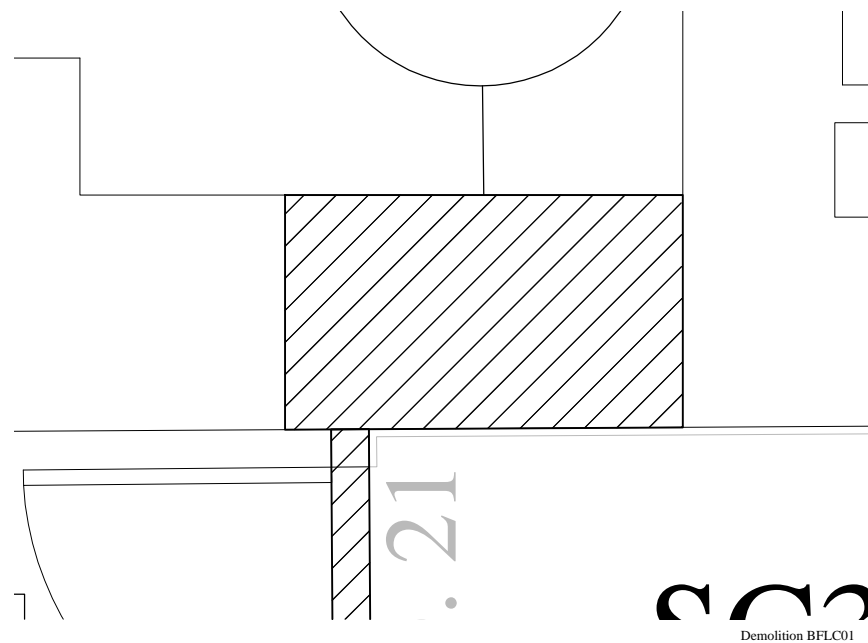
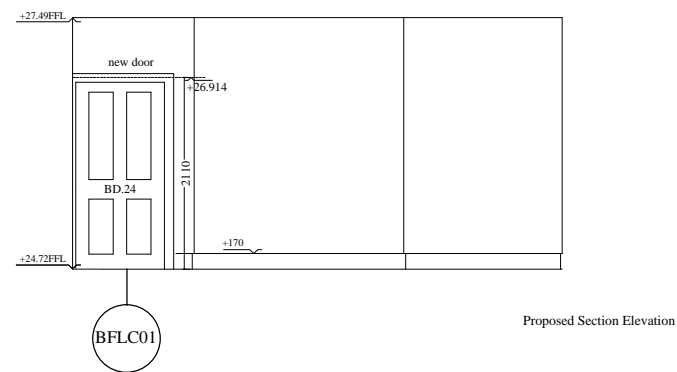
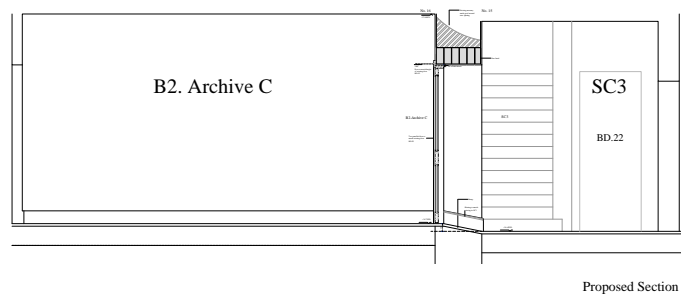
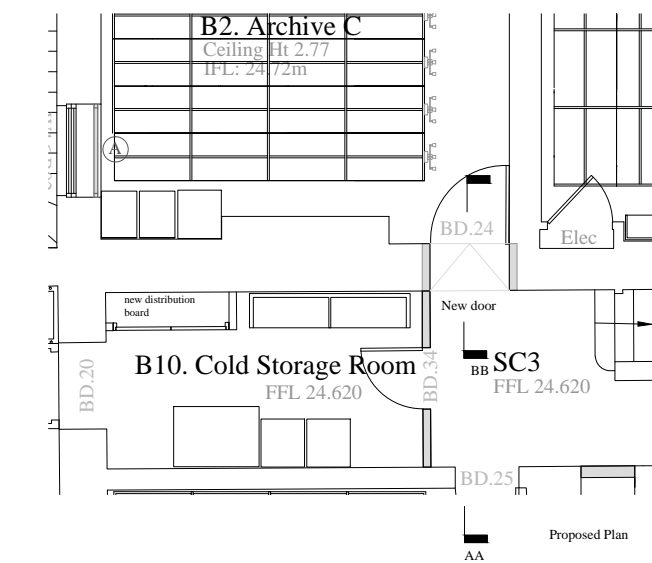

Image 3
Indicative location of lateral connection



NOTES:

REVISIONS:

THE PAUL MELLON CENTRE

LATERAL CONNECTION DETAIL
BASEMENT FLOOR

DRAWING NO:

400

SCALE:

1.50 @ A1

DATE:

26.08.14

WRIGHT & WRIGHT ARCHITECTS

89/91 Rayham Street
London NW1 0AG
TEL 020 7428 9393
FAX 020 7428 9394
www.wrightandwright.co.uk