

Performance Chart

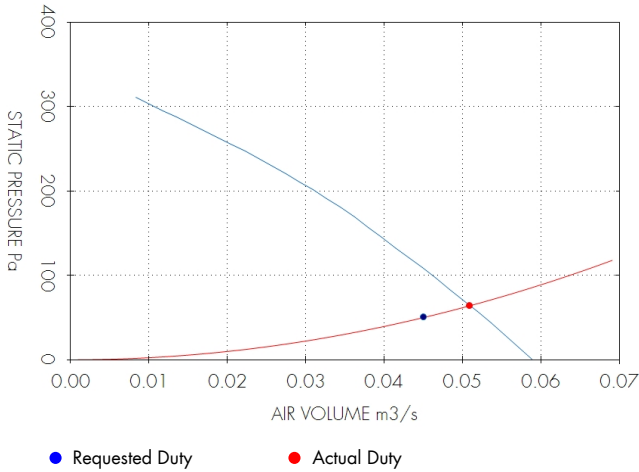

ACP10012

Requested Duty: 0.045 m³/s @ 50 Pa
 Actual Duty: 113% match
 Stock Reference: ACP10012
 Product Type: Ventilation
 Product Range: Unitary Fans
 Impeller: Backward Curved
 Casing: ABS thermoplastic
 Speed: 2740 rpm
 Airstream Temperature: -30°C to 40°C
 Specific Fan Power: 1.3 W/(l/s)
 dBA: 35
 eDemand inverter controlled to requested duty point
 Specific Fan Power: 1 W/(l/s)
 dBA: 32.3
 Stated dB(A) levels at 3m with spherical propagation at a reference level of 2 x 10⁻¹² Pa
 Specific Fan Power & dB(A) shown are at duty point.
 Warranty: 2 years

Acoustic Information

	63	125	250	500	1k	2k	4k	8k	Total	dB(A)@3m
Inlet	-	-	-	-	-	-	-	-	-	-
Outlet	-	-	-	-	-	-	-	-	-	-
Breakout	-	-	-	-	-	-	-	-	-	-

Sound Power Level Spectra dB (re 10⁻¹² Watts) shown @ free air.

Electrical Information

Watts: 83
 Supply Voltage: 220-240V/1/50Hz
 Full Load Current: 0.34 A
 Starting Current: 0.85 A
 Insulation: B
 Motor IP Rating: IP44
 S.T.O.P. Protection: Yes
 Speed Controllable: Yes

Optional Accessories

Part No	Description
10533100	FILTER CASSETTE 100
444164	eDemand 1 phase voltage controller
444169	eDemand 1 phase inverter
444744	DOL STARTER 240V 12A MAX
10542100	BACKDRAUGHT SHUTTER
10314103	3 AMP SINGLE PHASE CONTRO
10540100	FAST CLAMP 100MM

Part No	Description
444697	OVERLOAD 0.25-0.40A (DOL)
10536100	IN-LINE ATTEN. 010-090
W10303102M	INDUSTRIAL 2.5A CONTROLLE
10535100	IN LINE ATTEN. 010-060
10534100	IN LINE ATTEN. 010-030
10531100T1	HEAT.BATTERY+CONTROLS 100

Dimensions

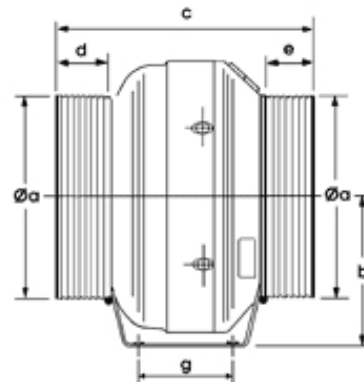
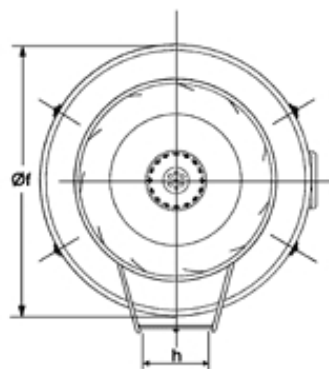

a	b	c	d	e	f	g	h
100	146	287	52	52	254	110	270

Dimensions shown in mm
Weights in kg