

**Combination Airbrick**

CODE **G930**

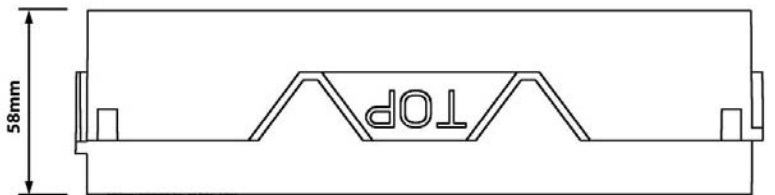
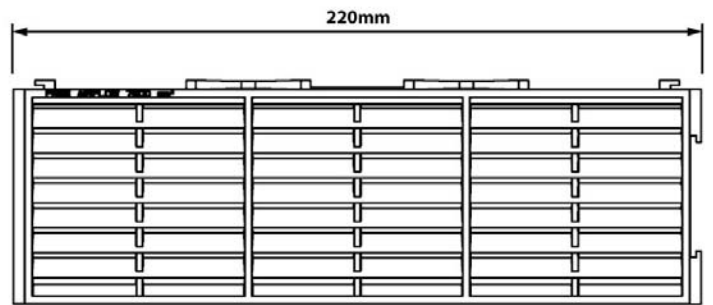
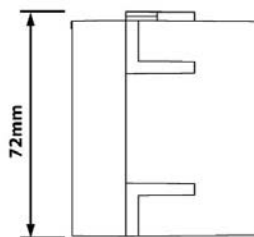
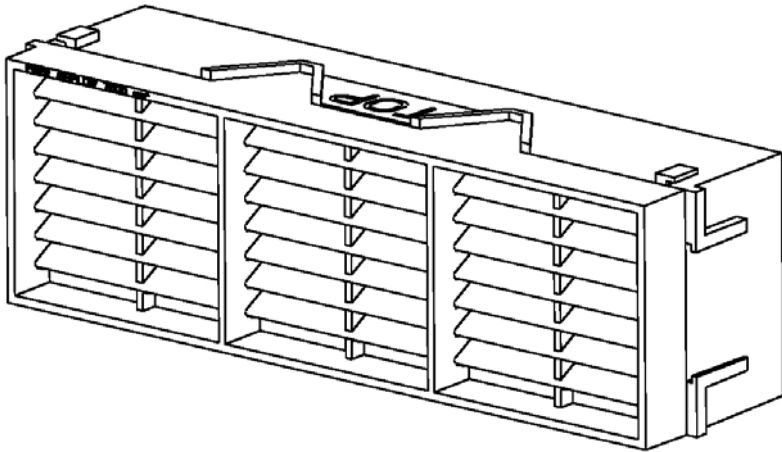

**Description:**

The G930 Combination Airbrick has been designed to provide high levels of ventilation into cavity walls and under floor voids.

The airbrick incorporates a front mounted grill which consists of evenly spaced openings specifically sized to prohibit large insects gaining access but wide enough not to be blocked by debris, paint or water droplets.

A mortar key around the fabric of the airbrick ensures secure adhesion to the building fabric while a clip together facility provides a choice of ventilation sizes.

COLOURS	Terracotta, Buff, Brown, Blue/Black, White, Grey
PACKING DETAILS	Packed in 20's per cardboard box
WEIGHT	2.5kg per pack
MATERIAL	Polypropylene
MANUFACTURING PROCESS	Injection Moulded
FREE AIRFLOW	7,600mm <sup>2</sup>

MANTHORPE BUILDING PRODUCTS LTD  
 MANTHORPE HOUSE  
 BRITAIN DRIVE  
 CODNOR GATE BUSINESS PARK  
 RIPLEY  
 DERBYSHIRE DE5 3ND

TEL: 01773 514 200  
 FAX: 01773 514 262  
 EMAIL: [sales@manthorpe.co.uk](mailto:sales@manthorpe.co.uk)  
 WEB: [www.manthorpe.co.uk](http://www.manthorpe.co.uk)

DRN MC      Date 20.07.05  
 The company maintains a policy of continuous development of its product range and reserves the right to amend the specification

DRG No  
**MBP 8054**  
 SHEET 1 OF 2

Issue  
**B**

Combination Airbrick

CODE **G930**

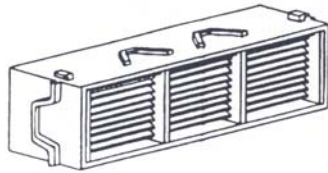
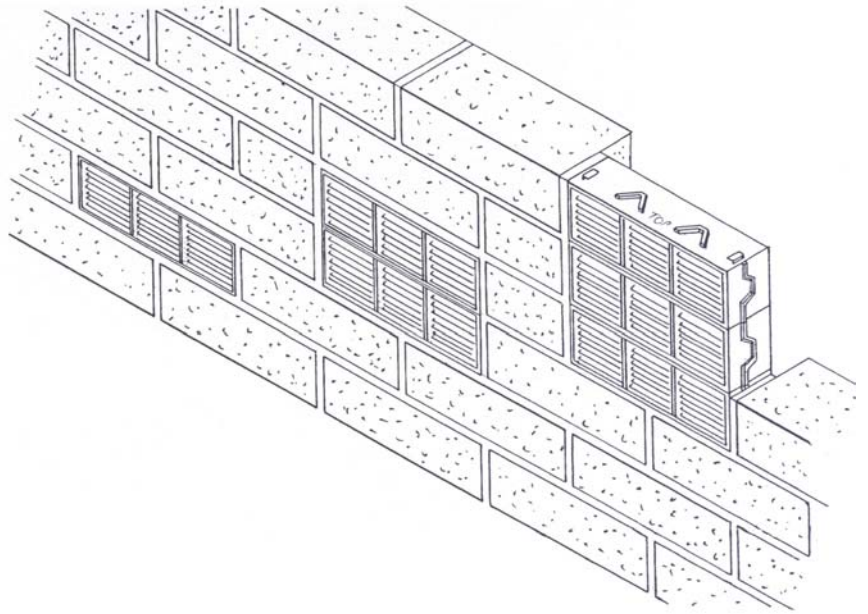

9"x3"

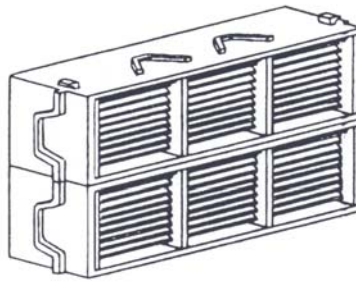
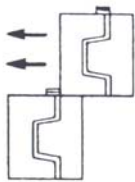

9"x6"

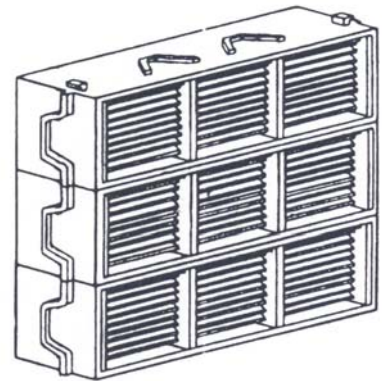

9"x9"

**Fitting Instructions:**

The G930 Combination Airbrick should be built into the brick course as per normal practice although care should be taken to keep the airflow passage clear from mortar droppings.

If the G930 Combination Airbrick is to be used in conjunction with other products from the Manthorpe range to provide a complete through wall ventilation system and the cavity has been bridged a suitable cavity tray should be fitted over the airbrick if above the D.P.C

**References:**

BRE: DIGEST 17/262  
 BRE: Floors, Flooring  
 DOE: Building Regs C4  
 NHBC: Standards 5.2