

This drawing is copyright and may not be copied or reproduced without the written consent of this practice

The contractor is responsible for setting out and must check all levels and dimensions prior to work being put in hand

This drawing should not be scaled. Only written dimensions are to be taken in respect of this project

The Architect is to be immediately notified of any suspected omissions or discrepancies

REV DATE COMMENT REV BY

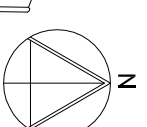

external appearance unaltered

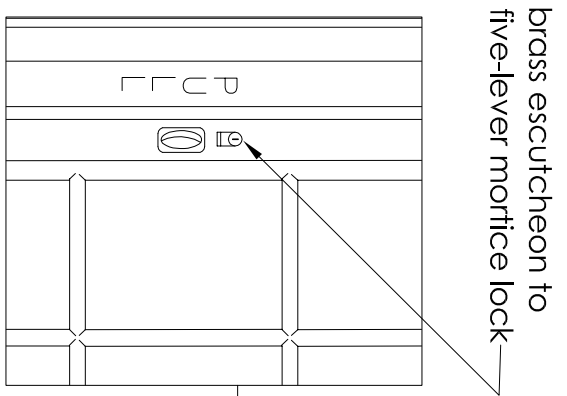

Proposed Detail 1 @ 1 : 10

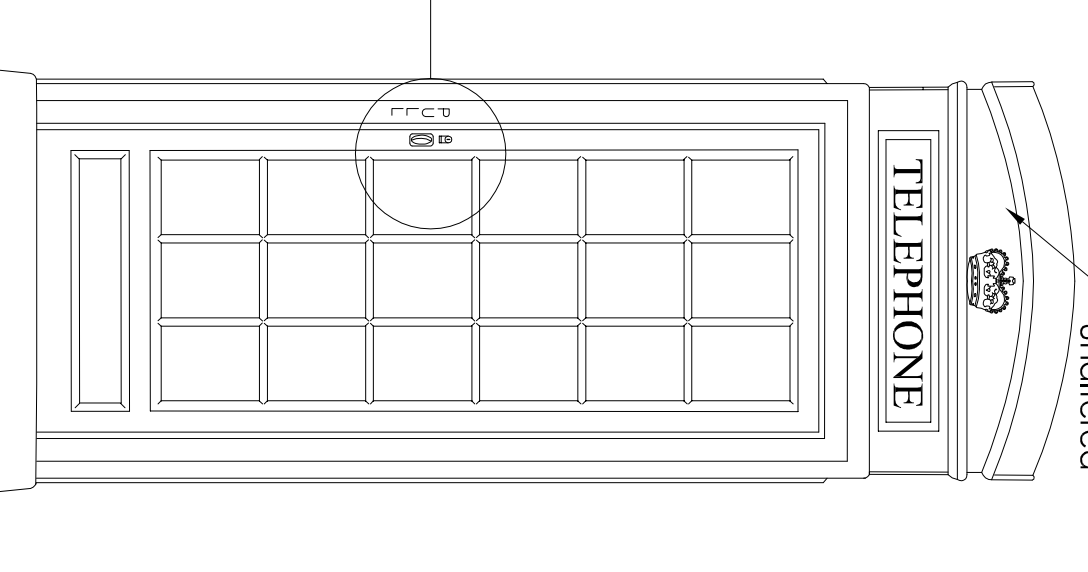

Proposed Front Elevation @ 1 : 20

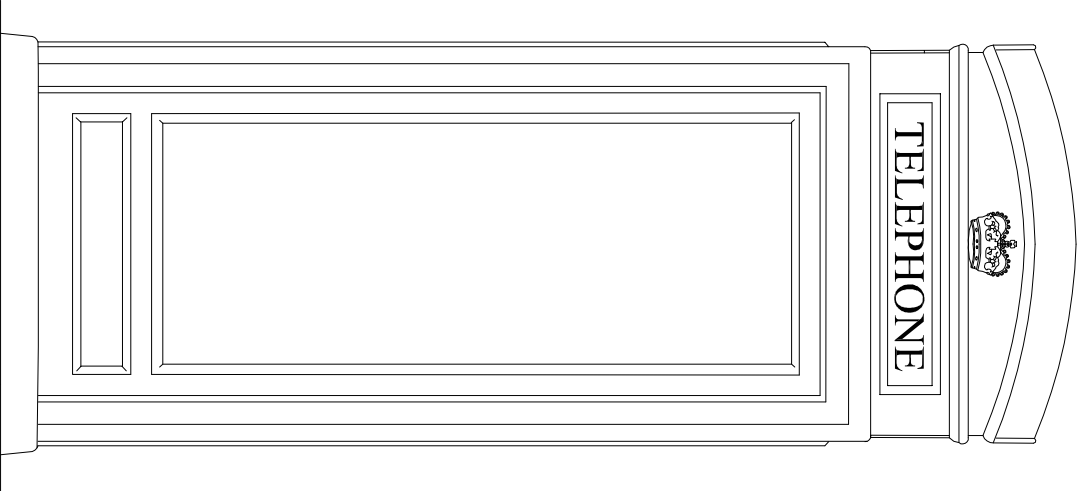

Proposed Rear Elevation @ 1 : 20

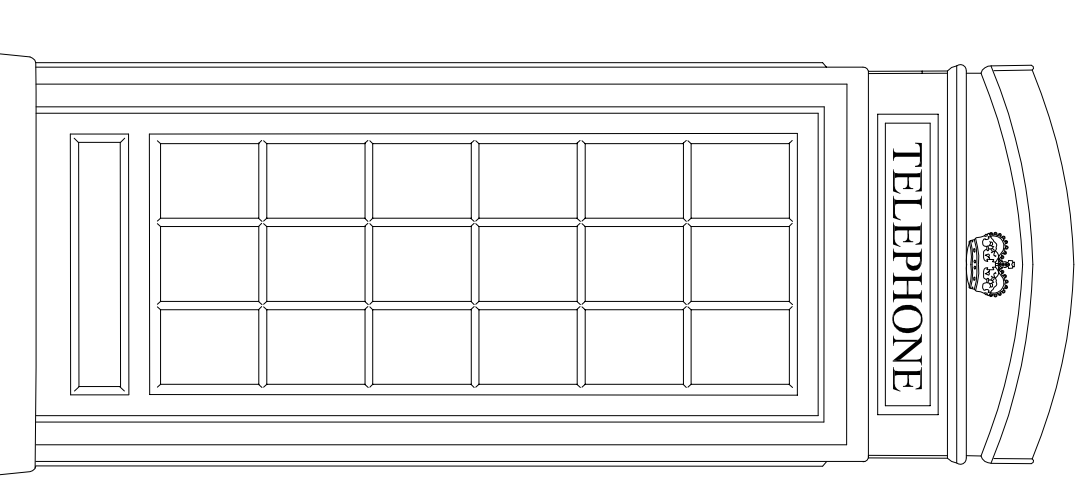

Proposed Side Elevation 1 @ 1 : 20

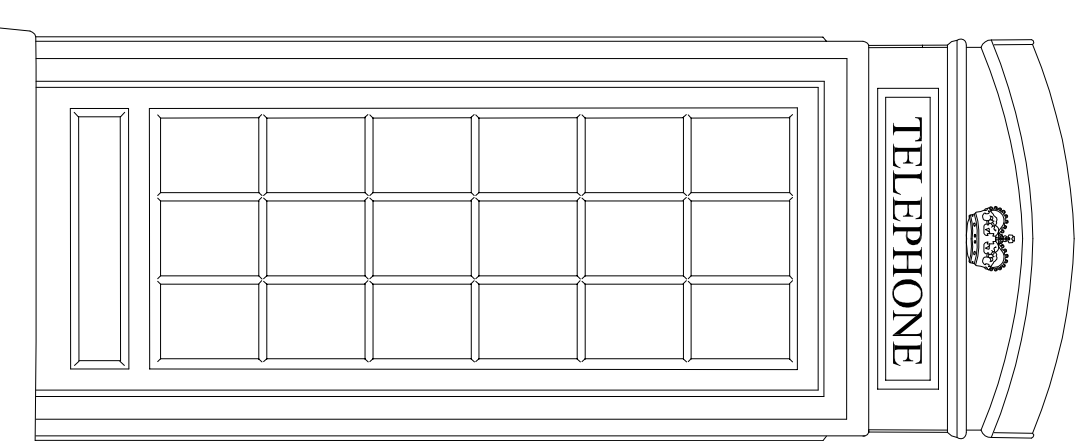

Proposed Side Elevation 2 @ 1 : 20

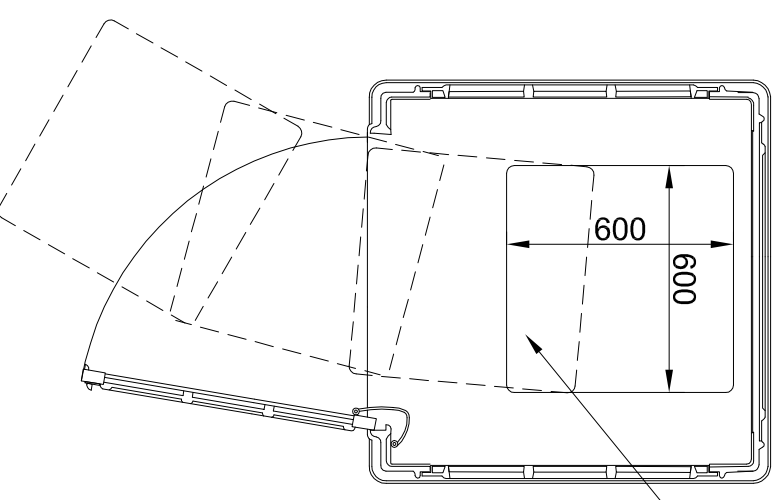

modular unit rolled into position on in-built rollers with no fixings to existing phone box shell

Proposed Plan Showing Door Open & Access for Modular Unit @ 1 : 20

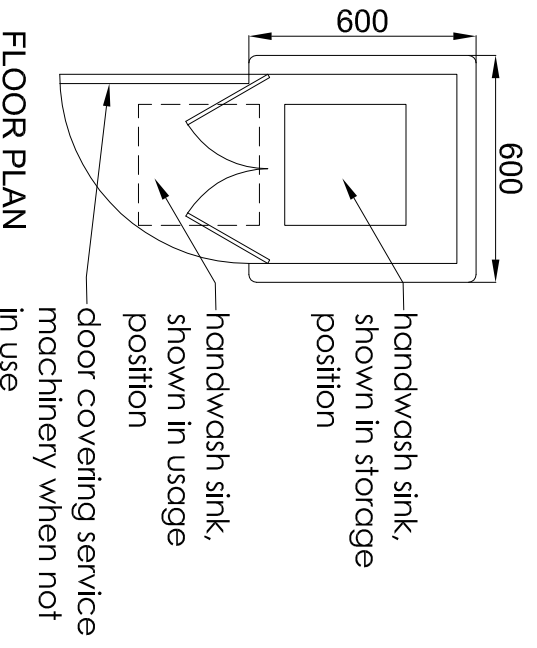

FLOOR PLAN

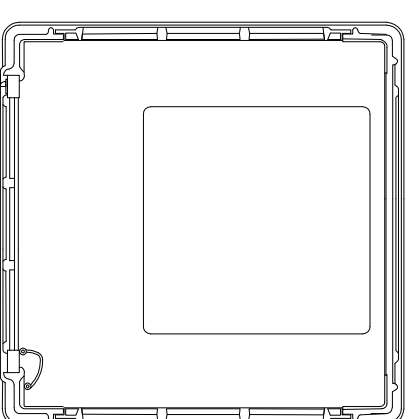

Proposed Plan Showing Door Closed @ 1 : 20

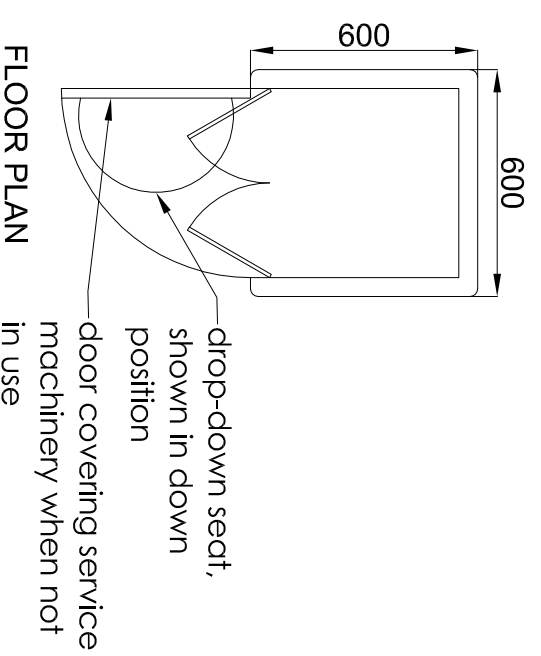

Typical Proposed Kiosk Plan 2 @ 1 : 20

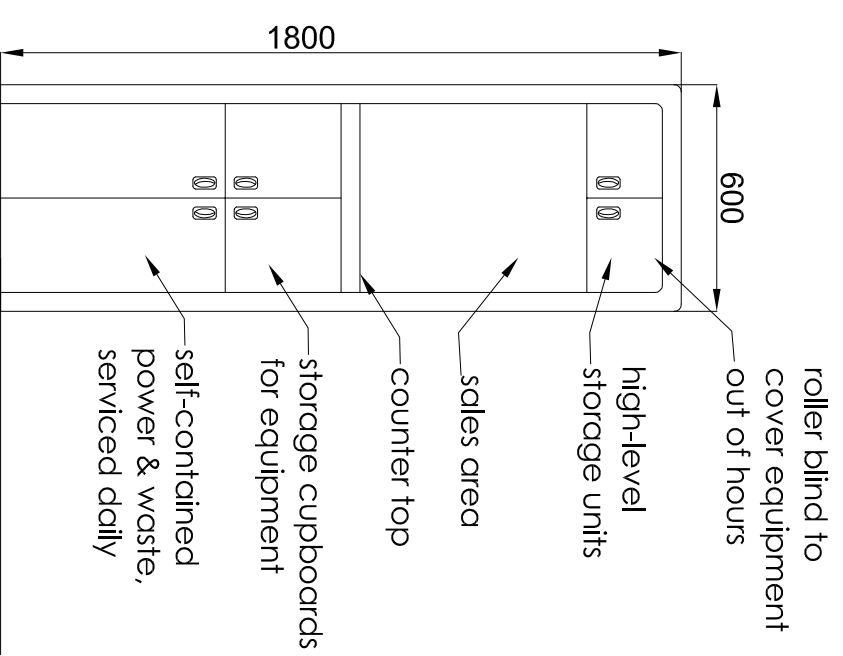

Typical Proposed Elevation of Modular Unit @ 1 : 20

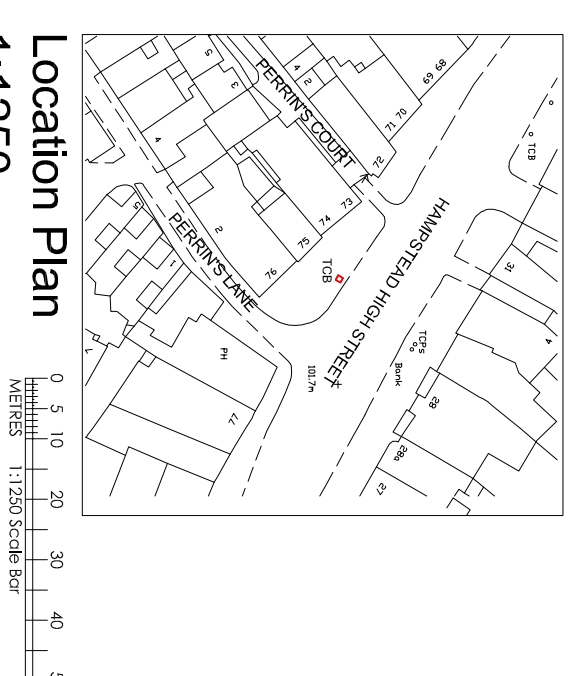

Location Plan 1:1250

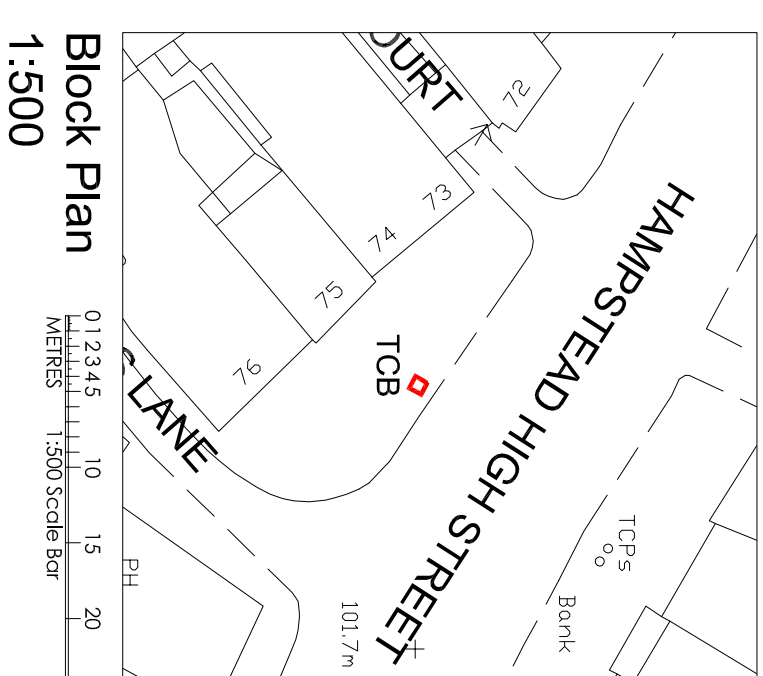

Block Plan 1:500

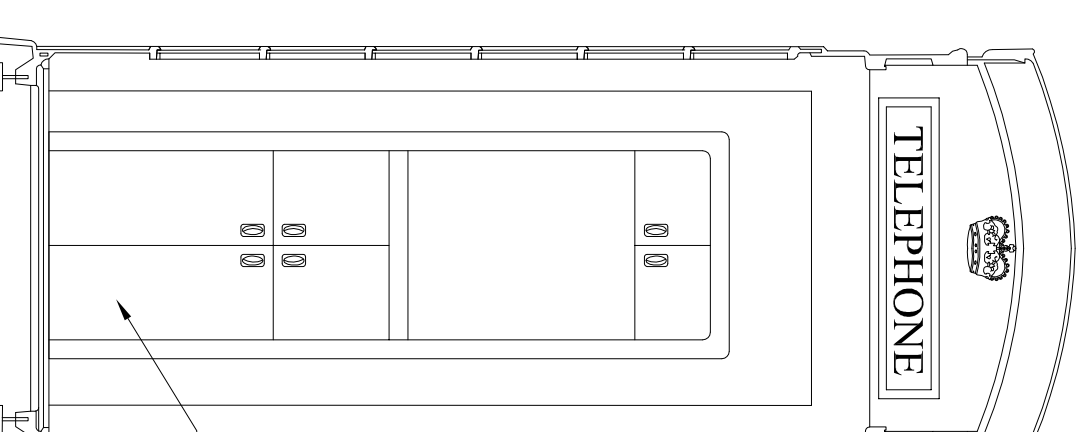

Typical Proposed Section A-A @ 1 : 20

modular unit rolled into position on retractable wheels with no fixings required to existing phone box shell

MILES BROE ARCHITECTURE LLP
CHARTERED ARCHITECTS AND PLANNING CONSULTANTS

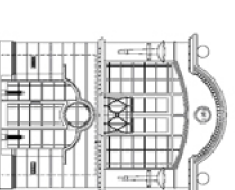

Coronation Studios, North Lane
104 North Road
Brighton, East Sussex, BN1 1YE
Telephone: 01273 625911
Fax: 01273 666381
www.milesbroearchitects.co.uk

CLIENT THINKING OUTSIDE THE BOX

PROJECT CHANGE OF USE FROM 1NO. PHONE BOX TO 1NO. RETAIL KIOSK

@ OUTSIDE 75 HAMPSTEAD HIGH STREET, LONDON, NW3 1QX

DRAWING

PROPOSED PLANS, ELEVATIONS, SECTIONS & DETAILS AND PROPOSED BLOCK & LOCATION PLANS - K2 KIOSK

scale	date	drawn
1:20, 1:500	May 2014	FMB
1:1250 @ A2		

job no	drawing no	revision
9232-16.1	PL01	