

Section D-D

Path
 50-60mm riven York stone dry butt jointed
 50mm paving sand
 150mm MOT type 2 well compacted

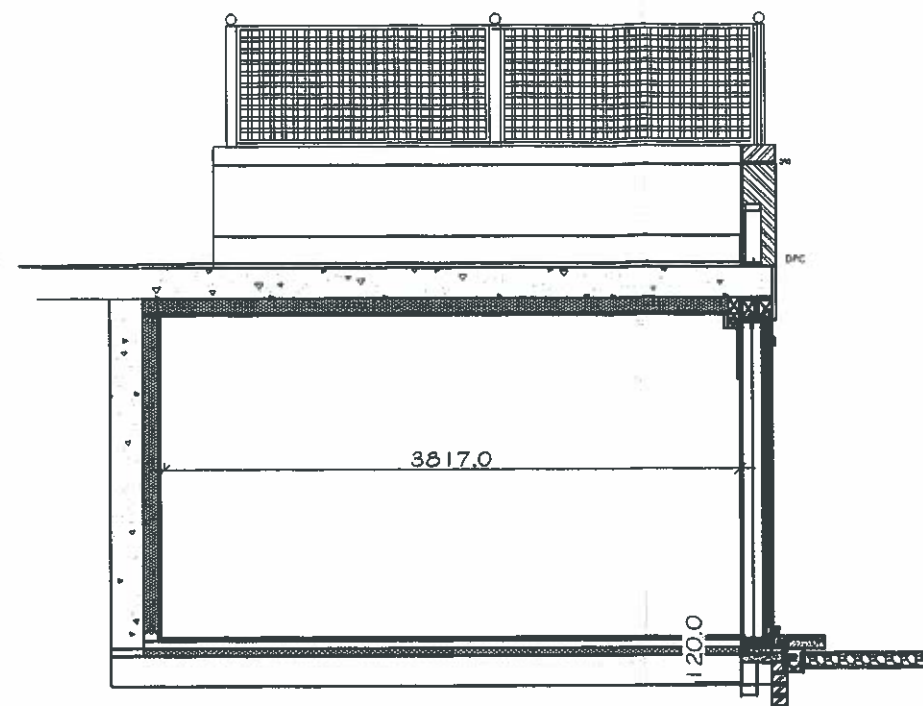

Elevation E

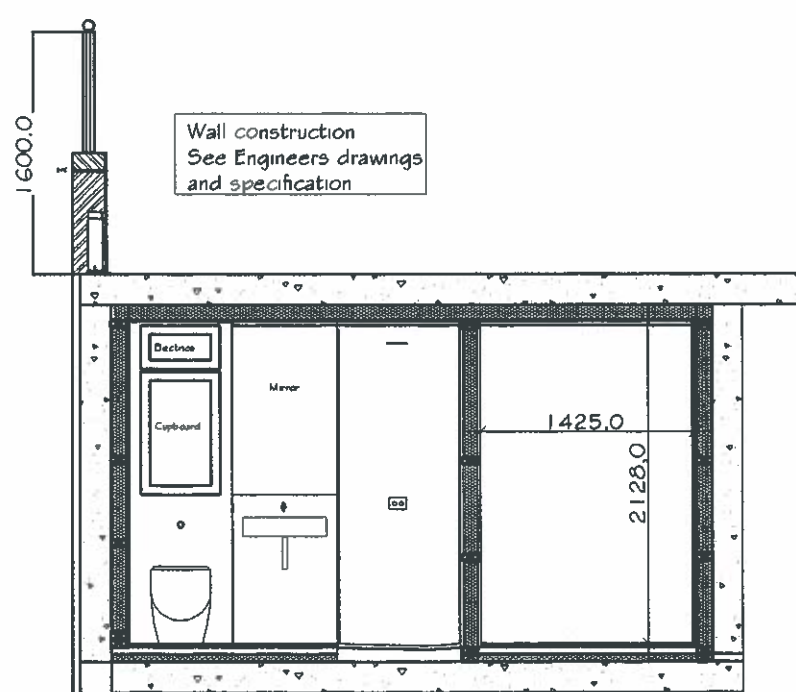

Section A

Wall construction
 See Engineers drawings
 and specification

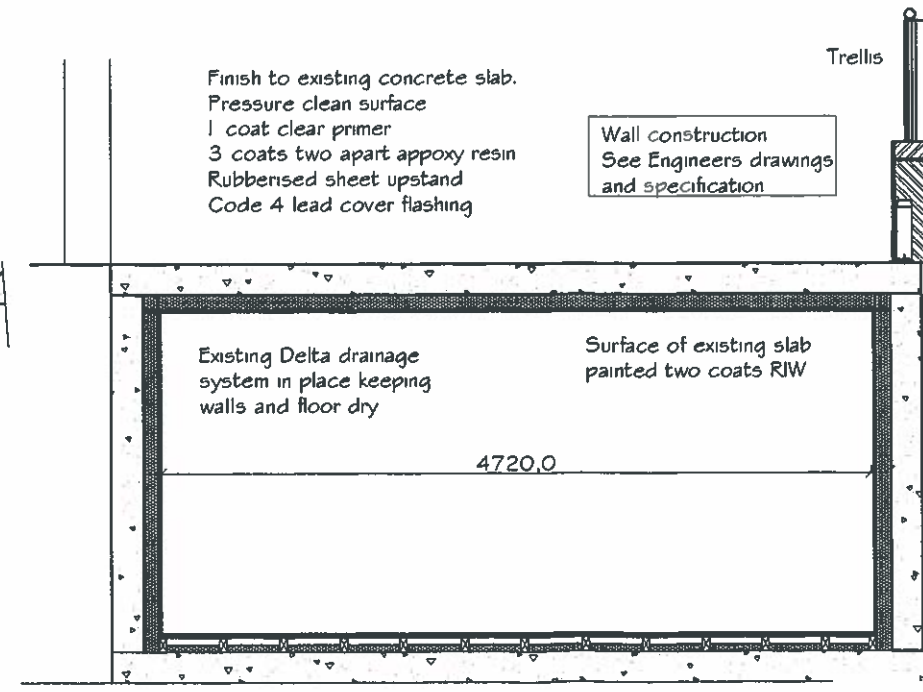

Elevation B

Finish to existing concrete slab.
 Pressure clean surface
 1 coat clear primer
 3 coats two apart epoxy resin
 Rubberised sheet upstand
 Code 4 lead cover flashing

Wall construction
 See Engineers drawings
 and specification

Slip brick cladding
 system with vertical
 DPC

Existing Delta drainage
 system in place keeping
 walls and floor dry

Surface of existing slab
 painted two coats RIW

Dixon Architects
 12 Oaklands Road
 London, N20 8BA,
 email - chris@dixonarchitects.com
 020 8567 1233

Project Address:
 3 The Mount
 Details of Parking Area

scale 1/50	date September 2014 20	drawn by 14
job ref. 3TM	drawing no. PA01	rev. A3 Sheet