

Annexure 1

Title Number : 320858

This title is dealt with by Land Registry, Croydon Office.

The following extract contains information taken from the register of the above title number. A full copy of the register accompanies this document and you should read that in order to be sure that these brief details are complete.

Neither this extract nor the full copy is an 'Official Copy' of the register. An official copy of the register is admissible in evidence in a court to the same extent as the original. A person is entitled to be indemnified by the registrar if he suffers loss by reason of a mistake in an official copy.

This extract shows information current on 17 FEB 2012 at 12:59:11 and so does not take account of any application made after that time even if pending in the Land Registry when this extract was issued.

REGISTER EXTRACT

Title Number	: 320858
Address of Property	: 15 Gayton Crescent, London (NW3 1TT)
Price Stated	: £1,800,000
Registered Owner(s)	: PHILIP ANTHONY GALWAY-COOPER and WENDY SUZANNE GALWAY-COOPER of 15 Gayton Crescent, London NW3 1TT.
Lender(s)	: Northern Rock (Asset Management) PLC Tiuta Developments Finance Limited

Annexure 2

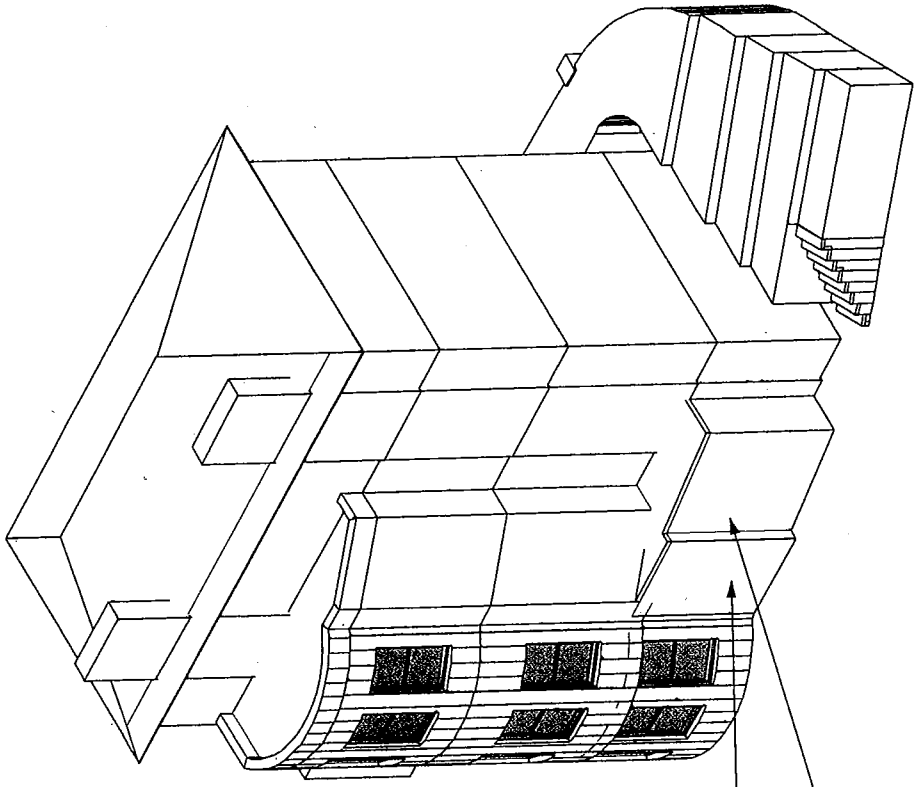

MC BLOCK (EXISTING)

THE SHED (EXISTING)

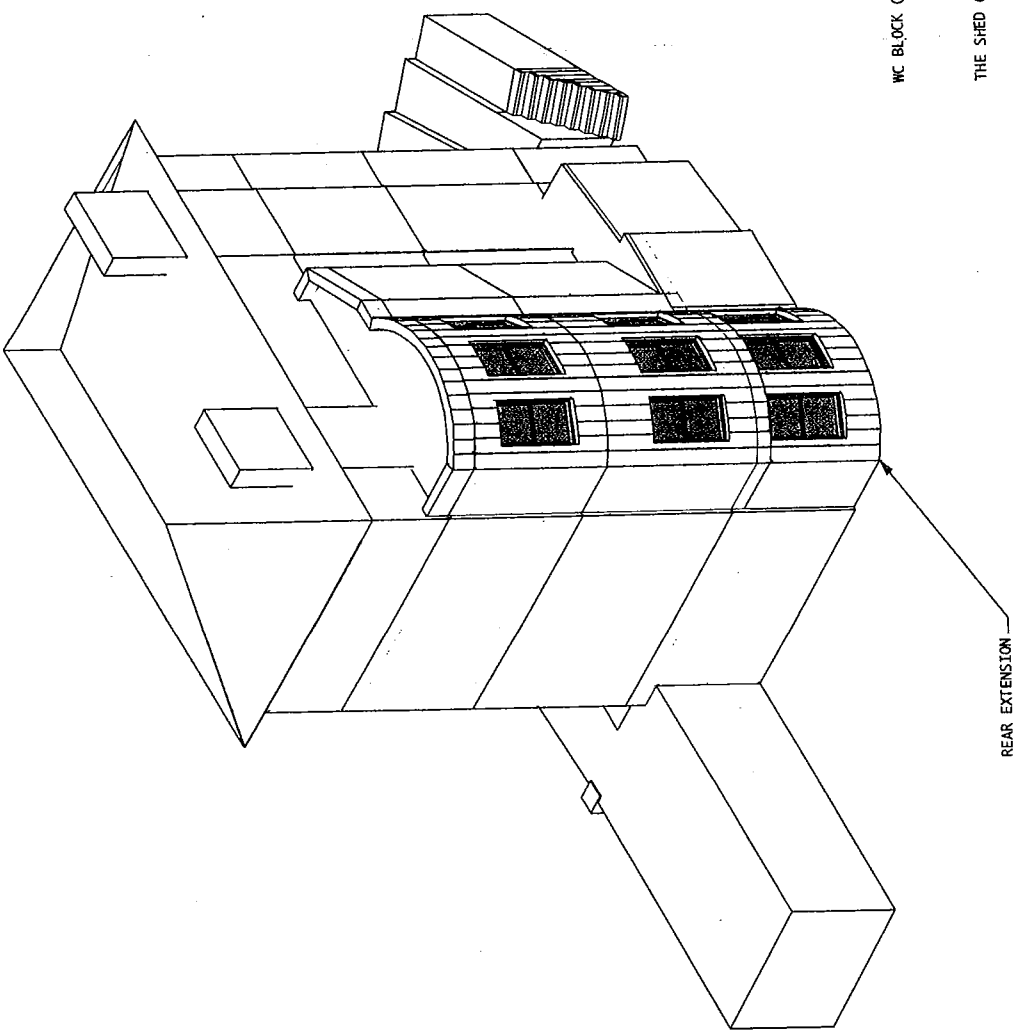

REAR EXTENSION

VOLUME CALCULATION

15 GAYTON CRESCENT
HAMPSTEAD
LONDON
NW3 1TT

EXISTING VOLUMES:

Roof	45.448	R/H Chimney Stack	2.309
Roof Plate	8.267	R/H Chimney Breast	2.827
House	649.065	Bathroom	10.766
Recess	-1.163	Bathroom Slab	1.075
L/H Bay Window	5.644	WC	29.836
Porch and Vault	31.147	WC Slab	1.085
R/H Bay Window	5.553	Shed	5.920
Floor Slab	16.195	Shed Slab	0.682
L/H Chimney Stack	2.273	TOTAL:	819.712 m³
L/H Chimney Breast	2.783		

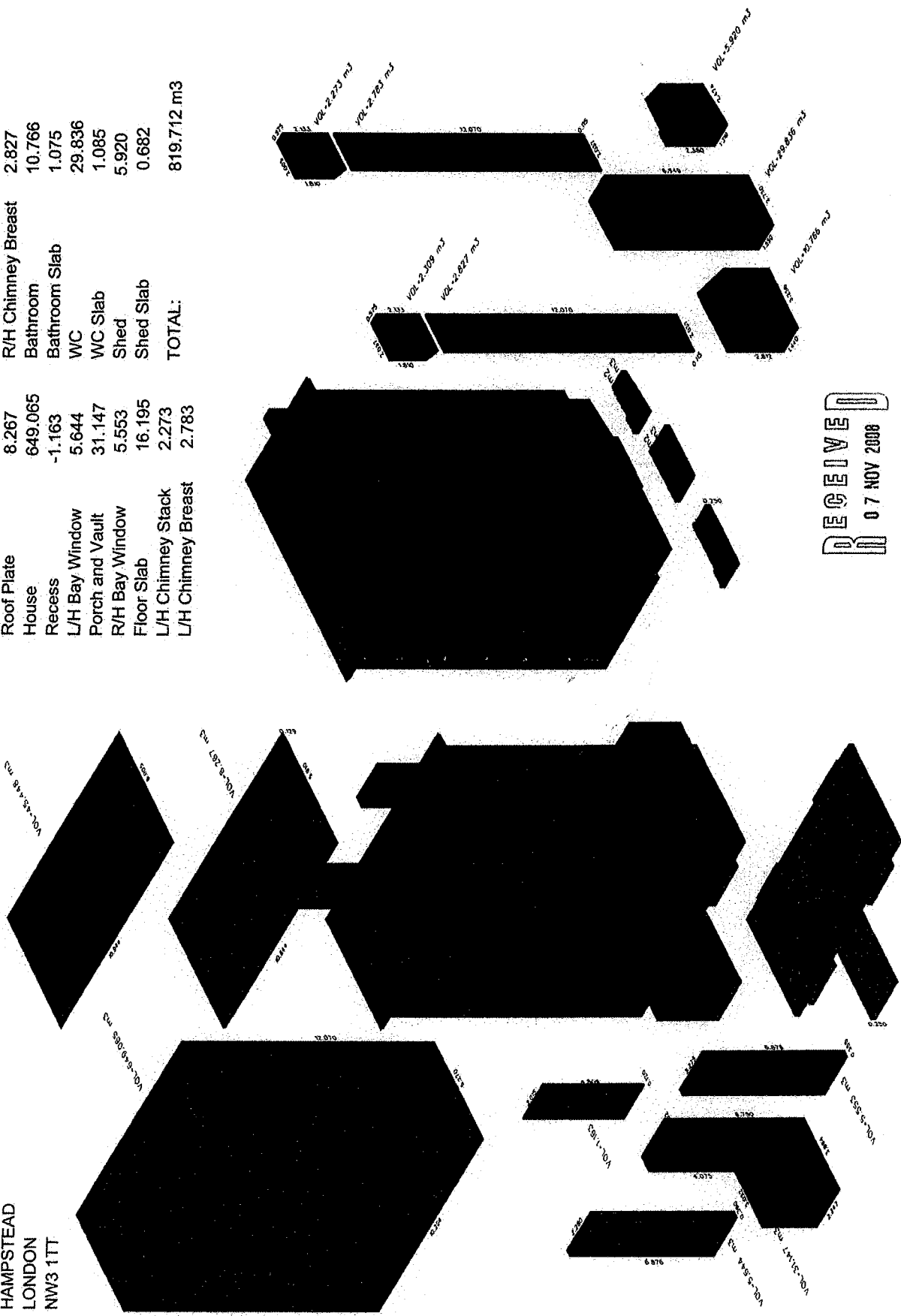

RECEIVED
07 NOV 2008

VOLUME CALCULATION

15 GAYTON CRESCENT
HAMPSTEAD
LONDON
NW3 1TT

PROPOSED VOLUMES:

Roof	45.448	R/H Chimney Stack	2.309
Roof Plate	8.267	R/H Chimney Breast	0.435
House	649.065	Extension	119.127
Recess	-1.163	Extension Slab	2.779
L/H Bay Window	5.644	Shed	5.710
Porch and Vault	31.147	Shed Slab	0.658
R/H Bay Window	5.553	TOTAL:	896.230 m3
Floor Slab	16.195		
L/H Chimney Stack	2.273		
L/H Chimney Breast	2.783		

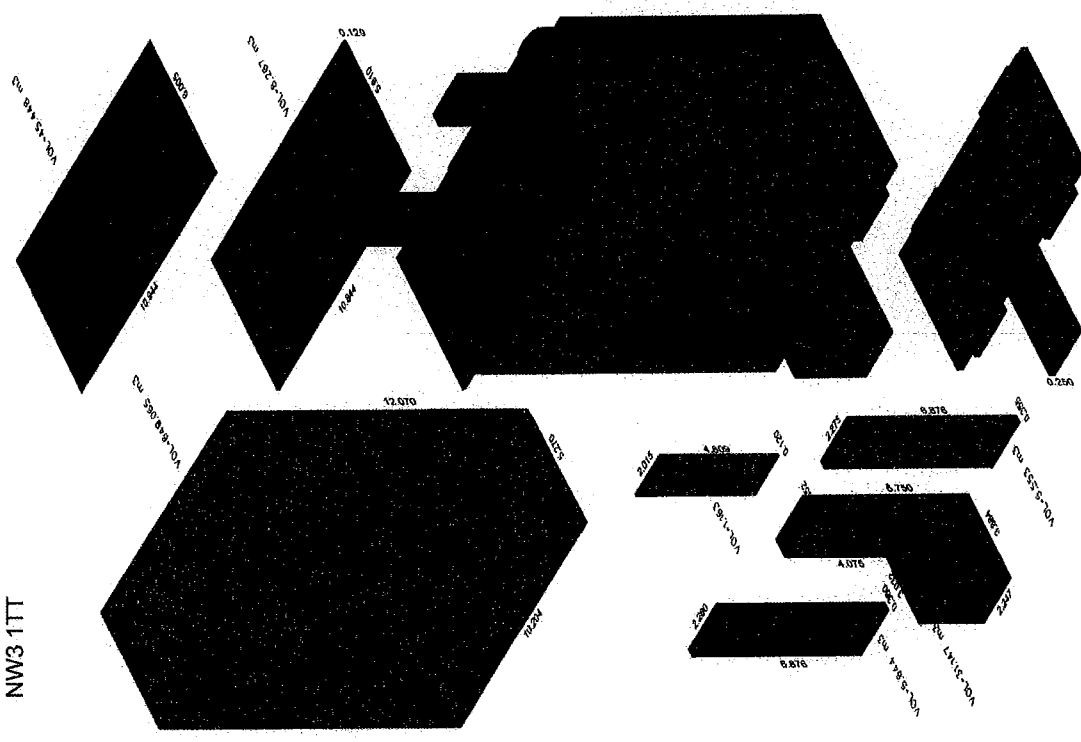

RECEIVED
07 NOV 2008

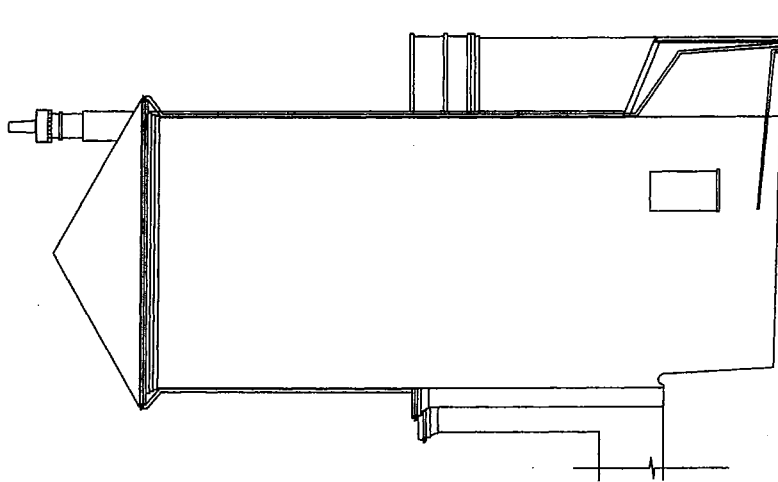

south flank elevation

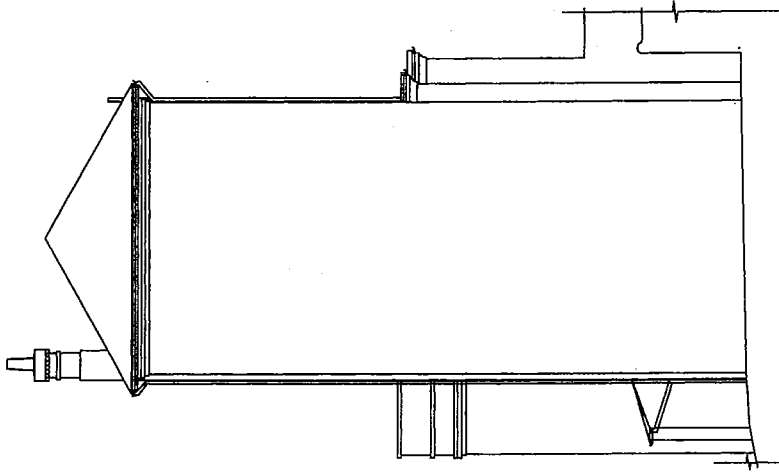

north flank elevation

1:1:00 at A3

RECEIVED
07 NOV 2008

TOM YOUNG ARCHITECTS
 19 Bassett St
 London NW5 4BG
 t_020749726100
 e_btyoung@mac.com

STAGE: feasibility, design, planning, tender, contract, handover, finish, material

DISCIPLINE: structural, mechanical, electrical, plumbing, drainage, fire, lift, etc.

SERIES: 1 site, roof, floor, etc.; 2 elevations; 3 sections; 4 enlarged plans; 5 details; 6 windows; 7 furniture; 8 other

PROJECT TITLE: 15 Gayton Crescent

JOB NUMBER: 0801

STAGE: ABC

SCALE: 1:100

DATE: Sept 08

ISSUE: CLIENT

CADWAZ: 0801_project_1.rvt

REVISIONS:

- 1 All dimensions to be checked on site
- 2 All discrepancies to be reported to architect or contract administrator immediately
- 3 Components to be fitted to the manufacturers requirements unless otherwise stated in writing
- 4 All work to be checked by SE
- 5 All work to DSE requirements
- 6 All items supply & fit by contractor unless otherwise stated

copyright for this drawing belongs to Tom Young Architects and may not be assigned to any other person or organization without TYA's written agreement

discipline	series	sheet	stage	rev
A	02	02	DES	

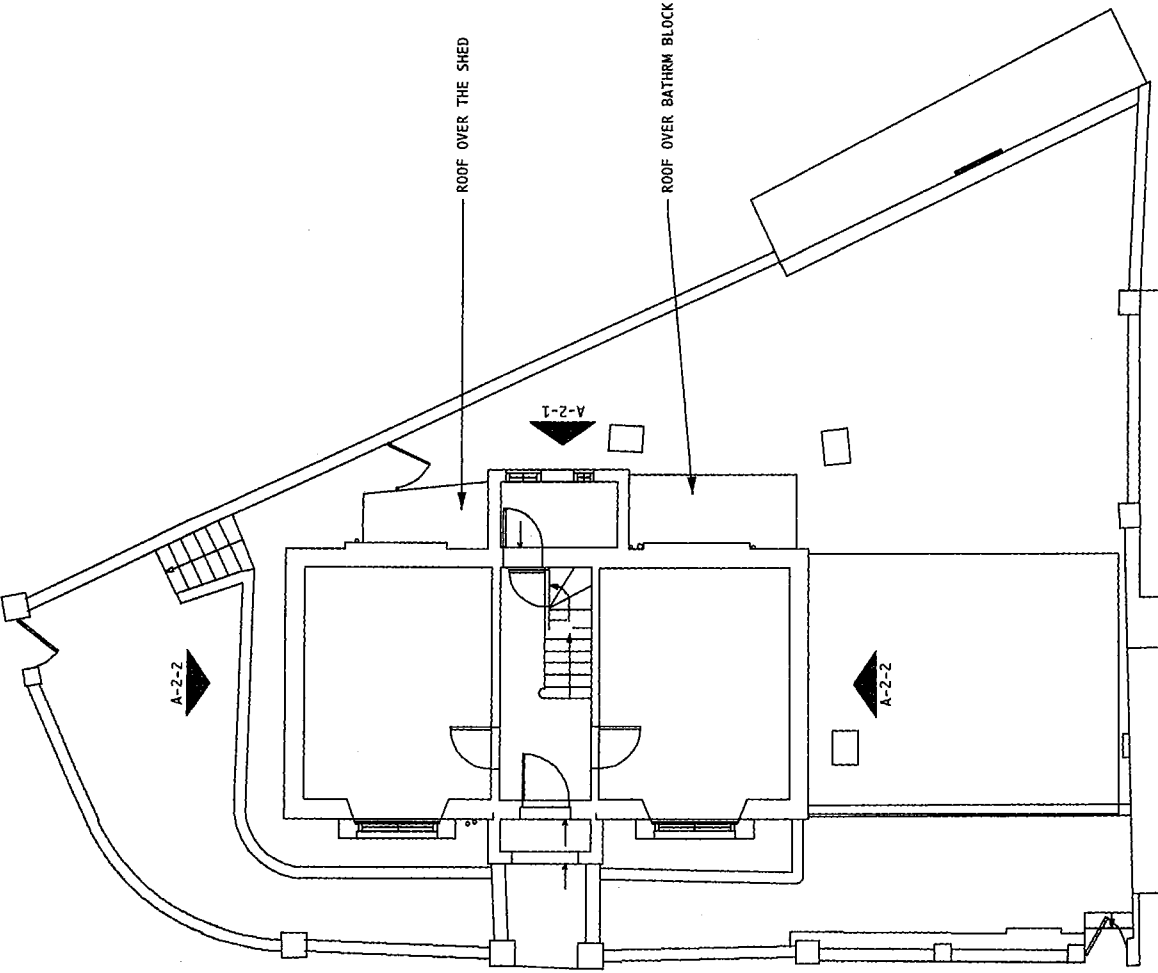

A-2-1

A-2-2

A-2-3

ROOF OVER THE SHED

ROOF OVER BATHRM BLOCK

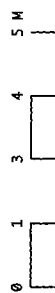

RECEIVED
07 NOV 2008

1:100 at A3

TOM YOUNG ARCHITECTS

19 Bassett St
London N15 4PG
t. 0203 775 378 300
e. thyoung@mac.com

existing raised
ground floor

discipline	series	sheet	stage	rev
A	01	02	DES	-

STAGE	feasibility	design	contract	land	contract	main
des	des	des	des	des	des	des

DISCIPLINE	A = architectural	S = structural	M = mechanical	E = electrical
SERIES	0 = cover sheet	1 = site, roof, floor	2 = elevations	3 = sections
	4 = elevations	5 = sections	6 = schedules	7 = views
	8 = other			

PROJECT TITLE	15 Goyton Crescent
JOB NUMBER	0801
STAGE	ABC
SCALE	1:100
DATE	Sept 08
ISSUE	CLIENT
CODE	0801_project_01e

REVISIONS

- 1 All dimensions to be checked on site
- 2 All discrepancies to be reported to architect or contract administrator immediately
- 3 All dimensions to be confirmed in writing
- 4 All dimensions to be confirmed by SE
- 5 All work to DS/SE requirements
- 6 All items supply & fit by contractor unless otherwise stated

copyright for this drawing belongs to Tom Young Architects and may not be assigned to any other person or organization without the written agreement

RECEIVED
07 NOV 2008

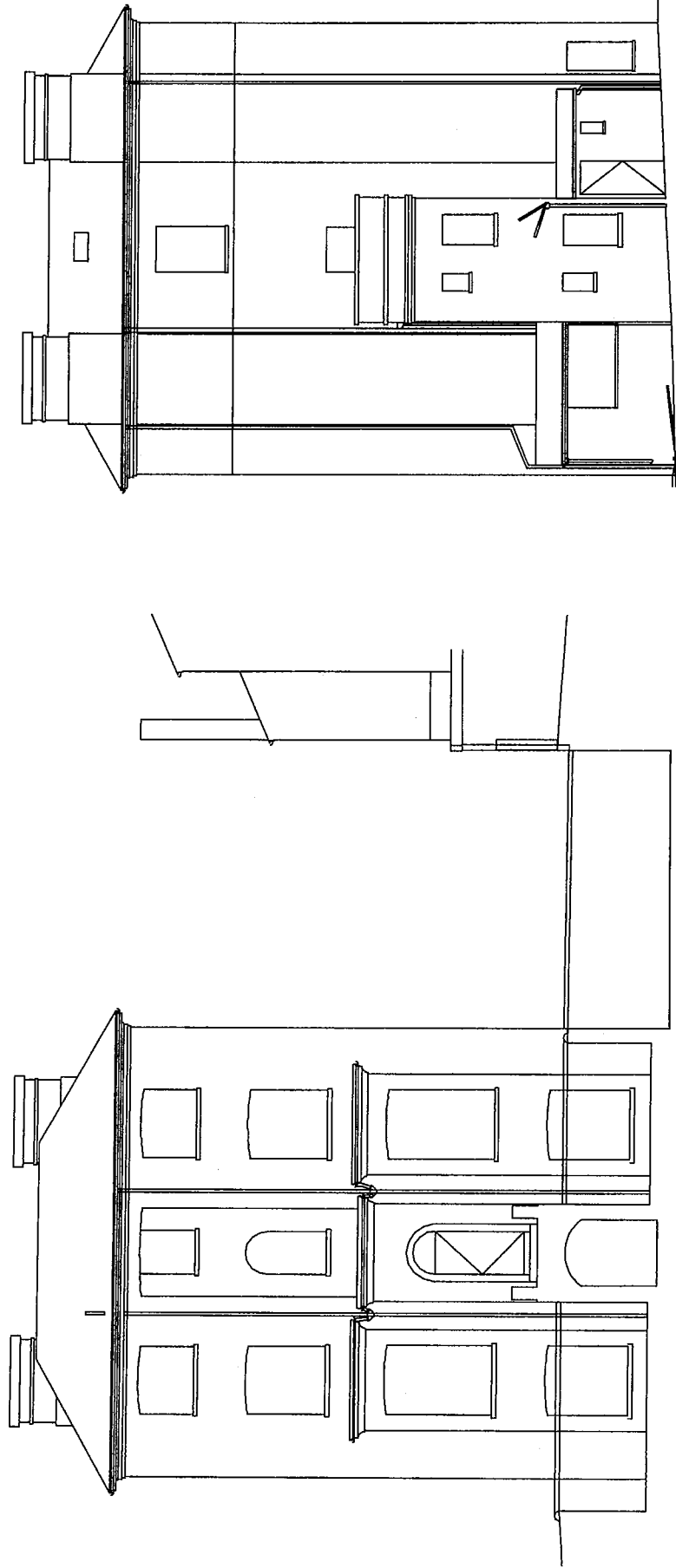

EXISTING FRONT ELEV'
5/8"

EXISTING REAR ELEV'

1:100 at A3

1 All dimensions to be checked on site.
2 All discrepancies to be reported to architect or contract administrator immediately.
3 Components to be fitted to the manufacturer's requirements unless otherwise stated in writing.
4 All dimensions to be confirmed by SE.
5 All items subject to manufacturer's requirements unless otherwise stated.
6 All items subject to fit by contractor unless otherwise stated.

Copyright for this drawing belongs to Tom Young Architects and may not be assigned to any other person or organization without the written agreement.

REVISIONS

PROJECT TITLE	15 Goyton Crescent
JOB NUMBER	0801
STAGE	ABC
SCALE	1:100
DATE	Sept 08
ISSUE	CLIENT
ISSUED BY	0801_project file

DISCIPLINE	SERIES	DESCRIPTION	DATE	BY
A = architectural	0 cover sheet	1 elevations		
M = mechanical	1 elevations	2 elevations		
E = electrical	2 elevations	3 elevations		
	3 elevations	4 elevations		
	4 elevations	5 elevations		
	5 elevations	6 elevations		
	6 elevations	7 elevations		
	7 elevations	8 elevations		

STAGE	feasibility	series	sheet	stage	rev
feas	planning	series	sheet	stage	rev
pln	bc	series	sheet	stage	rev
bc	contract	series	sheet	stage	rev
contract	manual	series	sheet	stage	rev
manual	existing front & back elev's	series	sheet	stage	rev

TOM YOUNG ARCHITECTS

19 Barrett St
Sydney NSW 150
t: 002 7482 6150
m: 07765 378 502
e: t.young@tomyoung.com.au
e: ch.young@mac.com



A-2-2

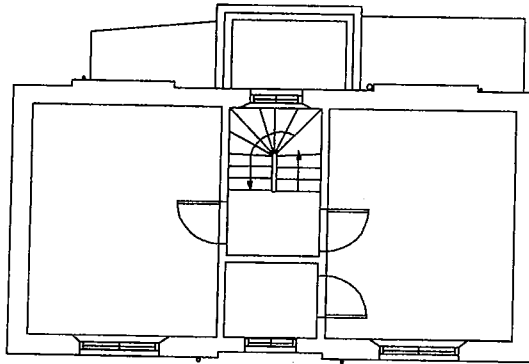

EXISTING FIRST FLOOR PLAN

A-2-1

A-2-1

A-2-1

A-2-2

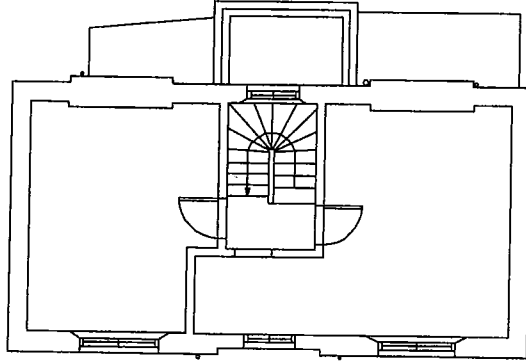

EXISTING SECOND FLOOR PLAN

A-2-2

RECEIVED
07 NOV 2008

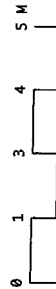

1:100 at A3

REVISIONS

- 1 All dimensions to be checked on site
- 2 All discrepancies to be reported to architect
- 3 Components to be checked immediately
- 4 All demotions to be confirmed by SE
- 5 All work to DS/SE requirements
- 6 All items supply & fit by contractor unless otherwise stated

copyright for this drawing belongs to Tom Young Architects and may not be assigned to any other person or organization without T/YA's written agreement

PROJECT TITLE		15 Goyton Crescent	
JOB NUMBER	0801	STAGE	ABC
SCALE	1:100	DATE	Sept 08
ISSUE	CLIENT	DATE	0801 project file

DISCIPLINE	SERIES	NO.	DESCRIPTION
A	architectural	1	cover sheet
M	mechanical	2	sections
E	electrical	3	elevations
S	structural	4	elevation & sections
M	mechanical	5	sections
E	electrical	6	schedules
S	structural	7	views
C	civil	8	center

STAGE	feasibility	19	Bassett St
design	London RMS APC	20	07.65.378.500
bid control	London RMS APC	21	e_shayoung@arc.com
tender	London RMS APC	22	existing first
contract	London RMS APC	23	& second flr plans
man	London RMS APC	24	

TOM YOUNG ARCHITECTS

discipline	series	sheet	stage	rev
A	01	03	DES	-

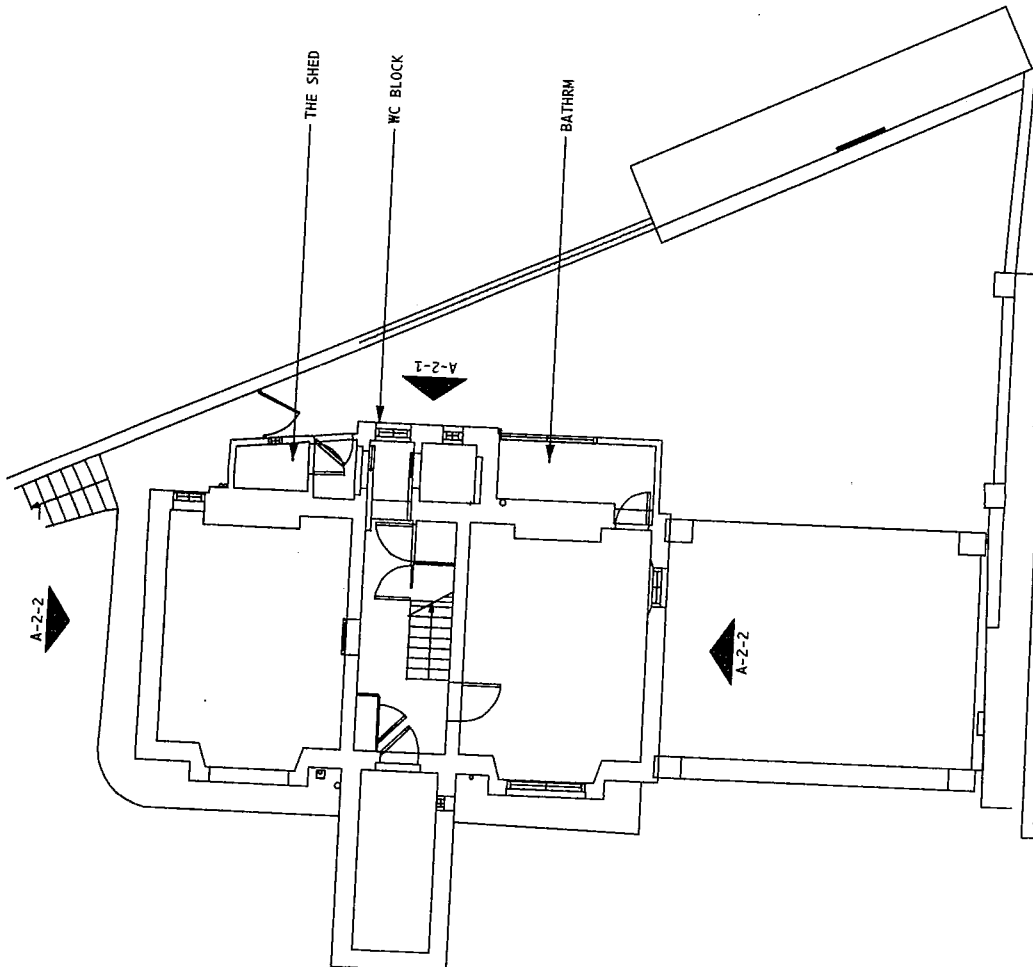

RECEIVED
07 NOV 2008

1:100 at A3

TOM YOUNG ARCHITECTS
 10 Bassett St
 London W14 9LW
 t_020 7482 6150
 f_07765 378 502
 e_tbyoung@mac.com

existing lower
ground floor

STAGE	feasibility	discipline	series
Arch	design	A	01
Str	contract	sheet	01
ME	drawings	stage	DES
0	contract	rev	-
1	initial		

DISCIPLINE	Architectural	PROJECT TITLE	15 Goyton Crescent
A	architectural	JOB NUMBER	0801
M	mechanical	STAGE	ABC
E	electrical	SCALE	1:100
0	cover sheet	DATE	Sept 08
1	plan, floor	ISSUE	CLIENT
2	elevations	CHANGE	0801_project_11a
3	sections		
4	dimensions & annotations		
5	schedules		
6	drawings		
7	drawings		
8	cover		

REVISIONS

- All dimensions to be checked on site
- All discrepancies to be reported to architect
- Contract administrator immediately
- Contract administrator to be fitted to the manufacturer's requirements
- All dimensions to be confirmed in writing
- All work to DS/SE requirements confirmed by SE
- All items supply & fit by contractor unless otherwise stated

copyright for this drawing belongs to Tom Young Architects and may not be assigned to any other person or organization without T.Y.A.'s written agreement

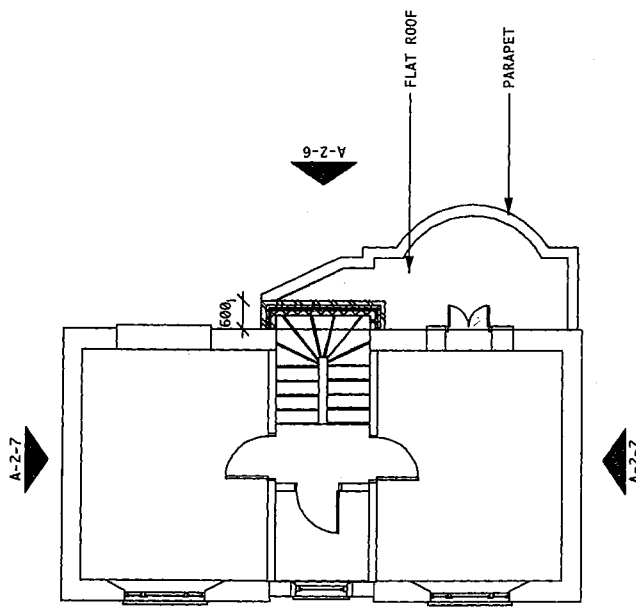
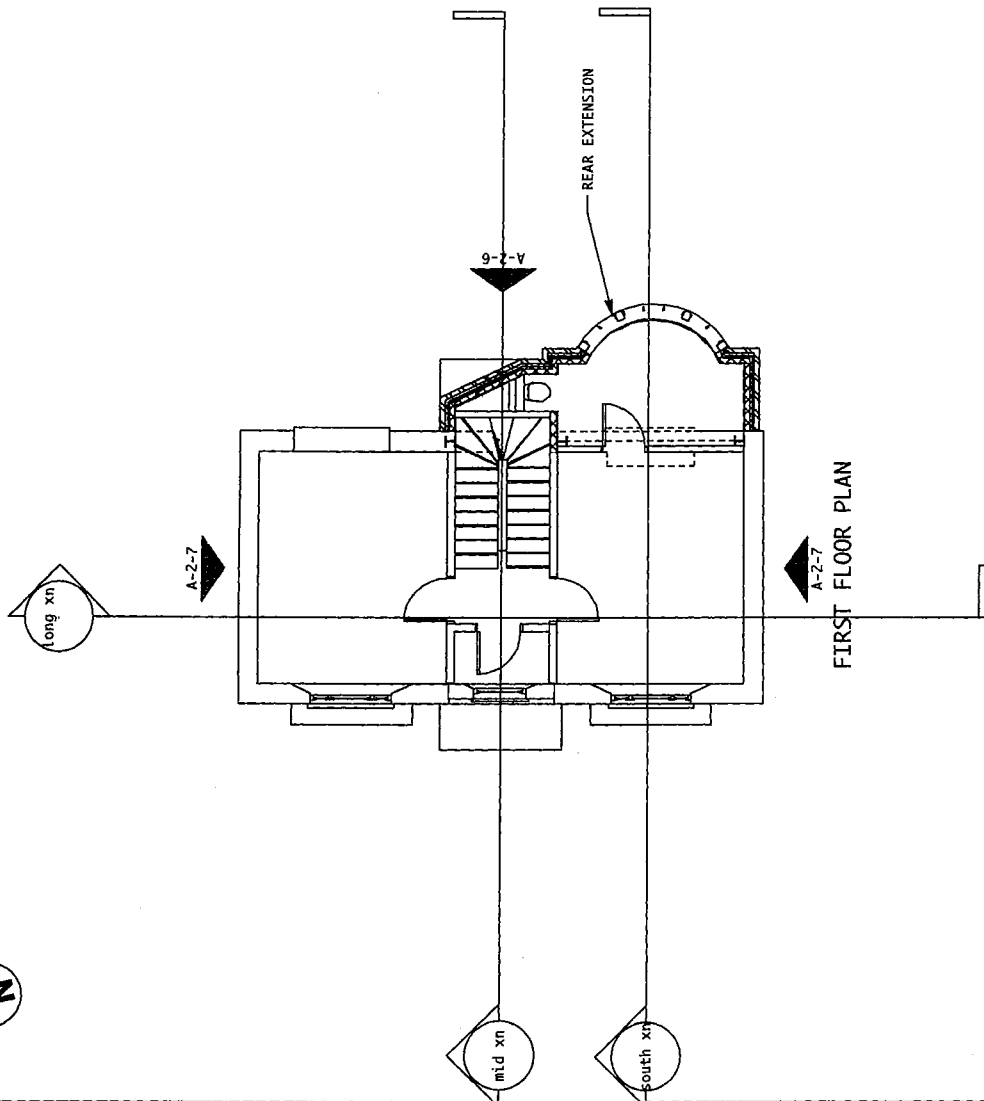

FIRST FLOOR PLAN

SECOND FLOOR PLAN

RECEIVED
07 NOV 2008

1:100 at A3

**TOM YOUNG
ARCHITECTS**

19 Bassett St
London NW5 4EG
t. 020 759 8100
f. 020 759 8101
e. tonyoung@mac.com

NEW FIRST + SECOND

STAGE	feasibility des = design con = construction bid = tender man = main	discipline	A = architectural S = structural M = mechanical E = electrical	PROJECT TITLE	15 Guyton Crescent
series	A	sheet	01	JOB NUMBER	0801
rev	C	stage	DES	SCALE	ABC
		date	07	DATE	Sept 08
		client	CLIENT	ISSUE	CLIENT
		count	0001	PROJECT TITLE	0001

DISCIPLINE	1 site, roof, floor 2 elevations 3 sections 4 structural steel, aluminium, glazing	REVISIONS	
STATUS	0 cover sheet 1 site, roof, floor 2 elevations 3 sections 4 structural steel, aluminium, glazing	1 All dimensions to be checked on site	
SECTION	5 sections 6 schedules 7 views 8 other	2 All discrepancies to be reported to architect	

3 Components to be fitted to the manufacturers requirements unless otherwise stated in writing

4 All demolitions to be confirmed by SE

5 All work to D/S/E requirements

6 All items supply & fit by contractor unless otherwise stated

copyright for this drawing belongs to Tom Young Architects and may not be copied or reproduced in any other form or medium without the written agreement of Tom Young Architects

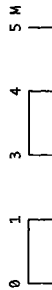

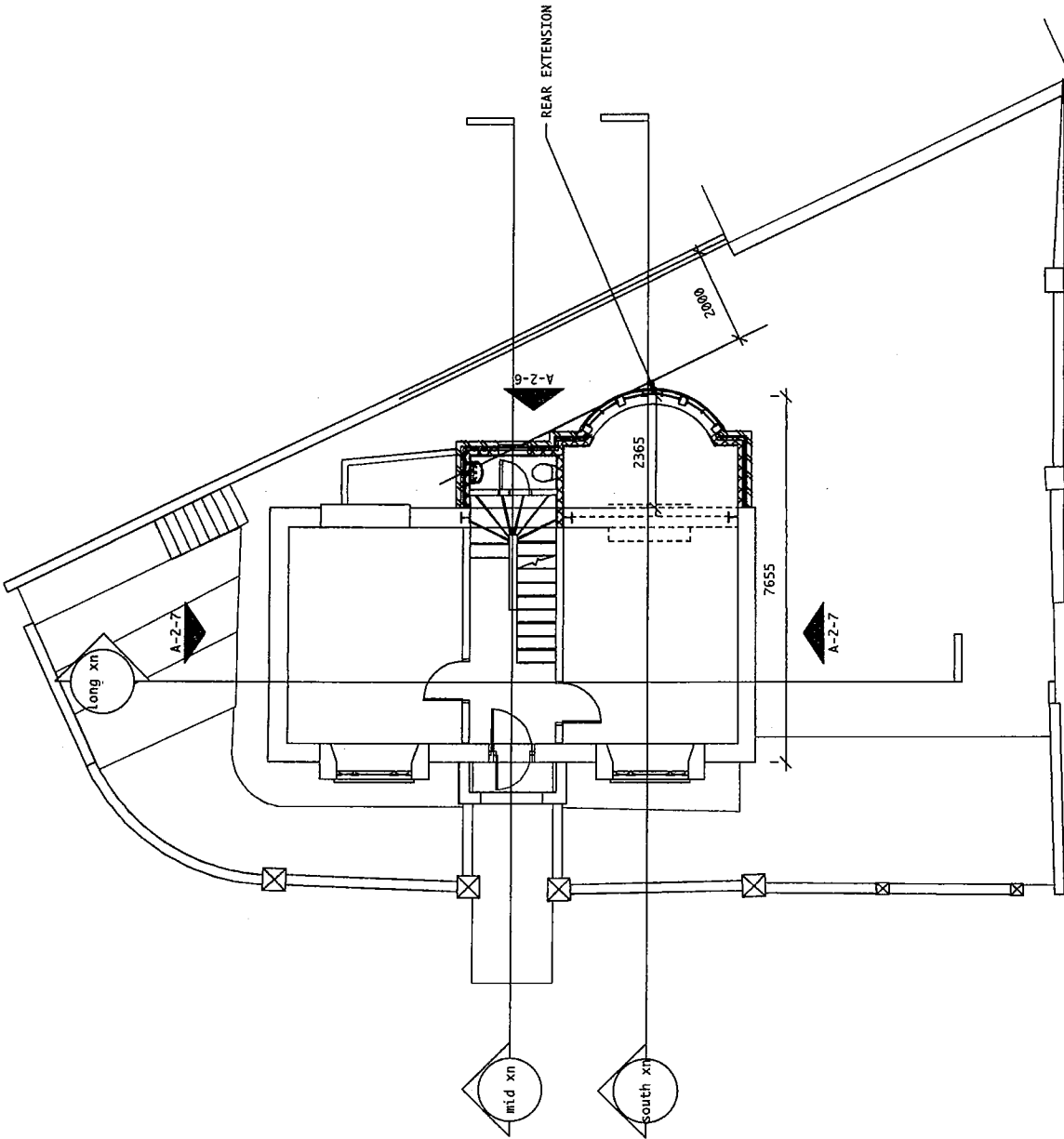

RECEIVED
 07 NOV 2008

1:100 at A3

TOM YOUNG ARCHITECTS

19 Baseett St
 Sydney NSW 1585
 t. 020 7482 6150
 f. 02765 378 502
 e. tdy@youngmac.com

NEW RAISED
 GROUND FLOOR

STAGE	feasibility	series	sheet	stage	rev
yes	design	A	01	06	C
no	contract				
pc	bid control				
land	tender				
contract	win				
man	manual				

DISCIPLINE	architectural
A	architectural
M	mechanical
E	electrical
SERIES	cover sheet
0	site, post, floor
1	elevations
2	sections
3	elevations & sections
4	schedules
5	views
6	other
7	
8	

PROJECT TITLE	15 Gayton Crescent
JOB NUMBER	0801
STAGE	ABC
SCALE	1:100
DATE	Sept 08
ISSUE	CLIENT
SCALE	0801_P01.dwg

REVISIONS	

- 1 All dimensions to be checked on site
- 2 All discrepancies to be reported to architect
- 3 Components to be fitted to the manufacturers requirements unless otherwise stated in writing
- 4 All demotions to be confirmed by SE
- 5 All work to DS/SE requirements
- 6 All items supply & fit by contractor unless otherwise stated

Copyright for this drawing belongs to Tom Young Architects and may not be assigned or used in any other project without T.Y.A.'s written consent.

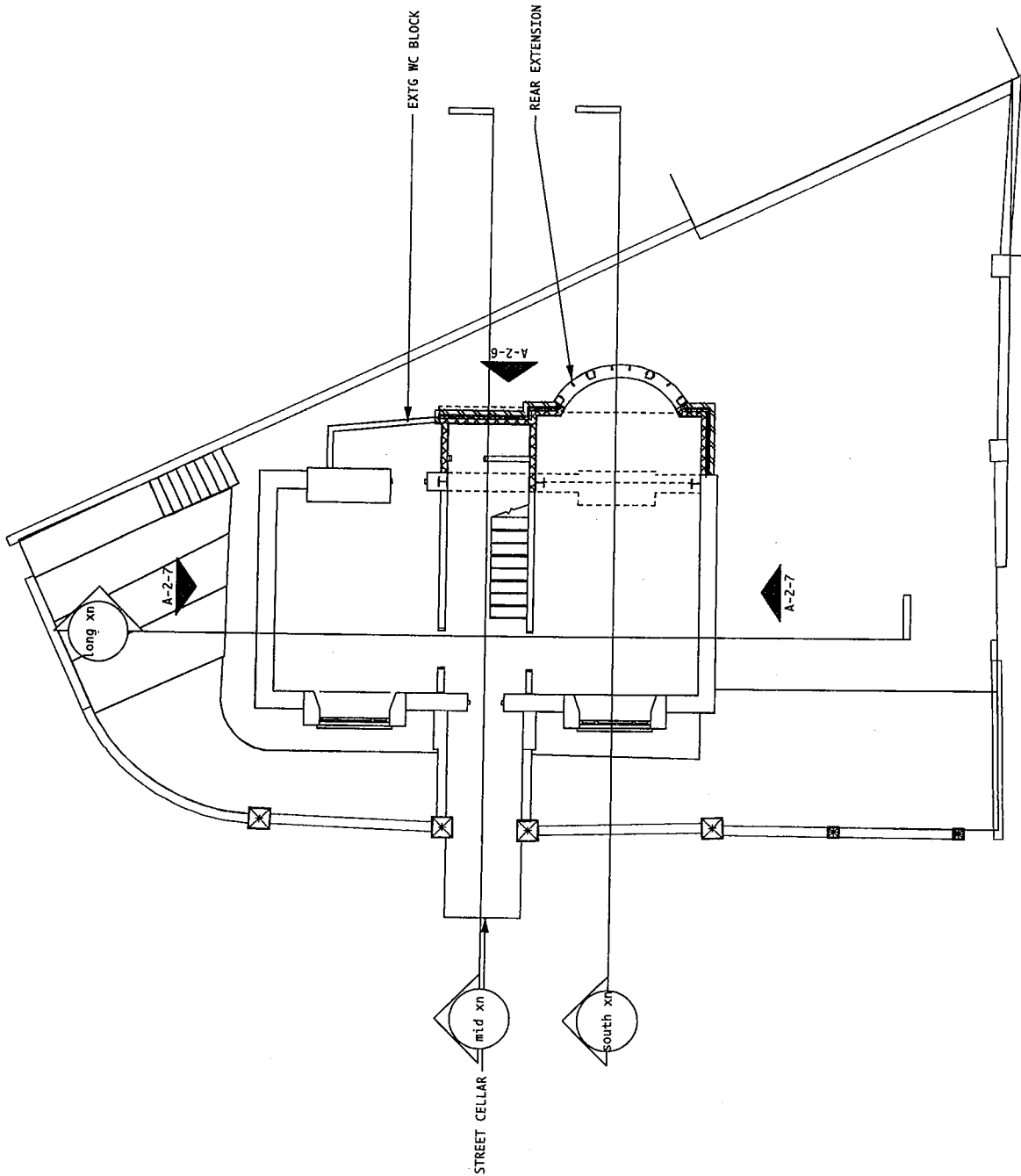

RECEIVED
 07 NOV 2008

1:100 at A3

TOM YOUNG ARCHITECTS

19 Bassett St
 London N5 4BG
 t. 020 7611 5150
 m. 07765 4376
 e. tbyoung@mac.com

new lwr ground floor

STAGE	feasibility	concept	design	bc	tender	contract	manual
discipline	architect	architect	architect	architect	architect	architect	architect
sheet	A	01	05	DES	C		

DISCIPLINE	A = architectural	M = mechanical	E = electrical
SERIES	0 cover sheet	1 Ala, roof, floor	2 sections
STAGE	ABC	1:100	Sept 08
SCALE	1:100	CLIENT	0801
DATE	CLIENT	0801	0801
ISSUE	CLIENT	0801	0801
CADNAME	0801	0801	0801

PROJECT TITLE	15 Goyton Crescent
JOB NUMBER	0801
STAGE	ABC
SCALE	1:100
DATE	Sept 08
ISSUE	CLIENT
CADNAME	0801

- REVISIONS
- 1 All dimensions to be checked on site
 - 2 All discrepancies to be reported to architect or contract administrator immediately
 - 3 Components to be fitted to the manufacturers' drawings
 - 4 All dimensions to be confirmed in writing
 - 5 All work to BS/SE requirements
 - 6 All items supply & fit by contractor unless otherwise stated

copyright for this drawing belongs to Tom Young Architects and may not be assigned to any other person or organization without TYA's written agreement

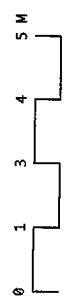

NEW SLATE LEAN-TO
OVER STAIR SHELL

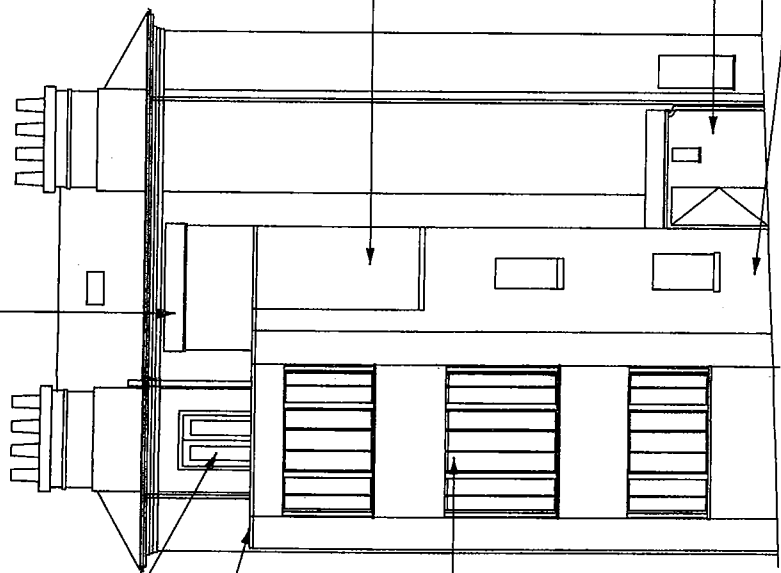

REAR ELEV'

1:100 at A3

RECEIVED
07 NOV 2008

- REVISIONS
- 1 All dimensions to be checked on site
 - 2 All discrepancies to be reported to architect on contract administrator immediately
 - 3 All work to be done in accordance with the contract documents unless otherwise stated in writing
 - 4 All demolitions to be confirmed by SE
 - 5 All work to DS/SE requirements
 - 6 All items supply & fit by contractor unless otherwise stated

copyright for this drawing belongs to Tom Young Architects and may not be assigned to any other person or organization without T.Y.A.'s written agreement

PROJECT TITLE		15 Gayton Crescent	
JOB NUMBER	0801	STAGE	ABC
SCALE	1:100	DATE	Sept 08
ISSUE	CLIENT	ISSUE	CLIENT
CHANGE	0801_project_its		

DISCIPLINE	structural	series	0 cover sheet
A	mechanical	1	plans
M	electrical	2	elevations
E		4	enlarged plans, elevations & details
		5	schedules
		9	other

STAGE	feasibility	discipline	A
1	concept	series	02
2	preliminary	sheet	06
3	final design	stage	des
4	contract	rev	-

TOM YOUNG ARCHITECTS

19 Barastock St
London E1 1AA
t 020 7482 6130
m 07765 378 502
e chy@tomyoungllc.com

NEW REAR ELEV'

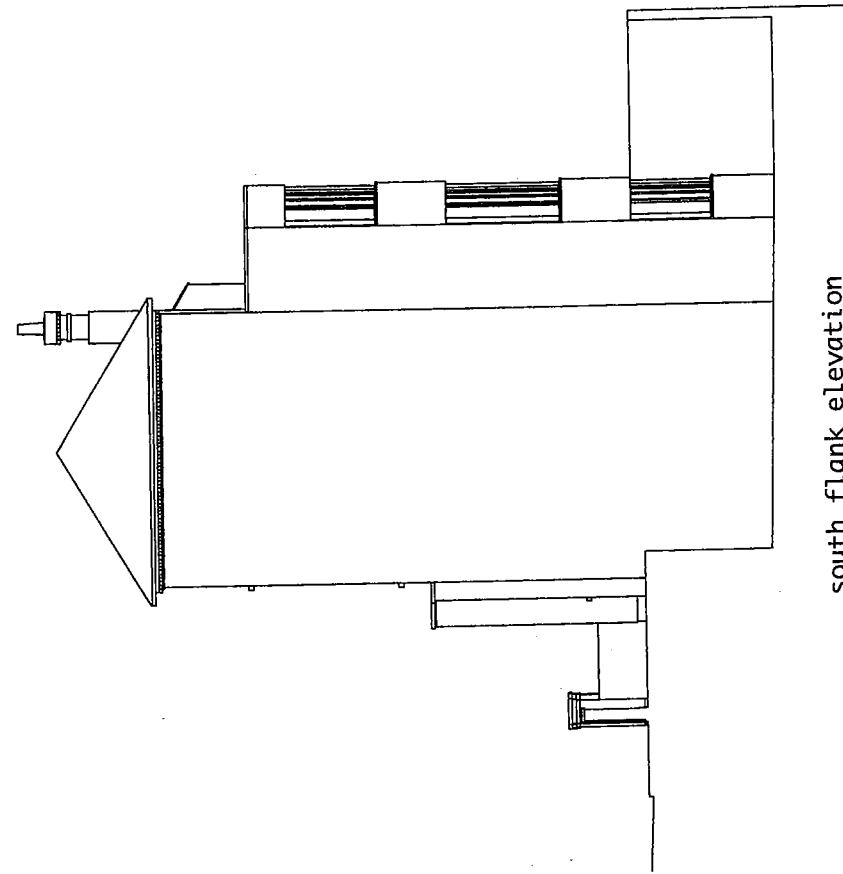

south flank elevation

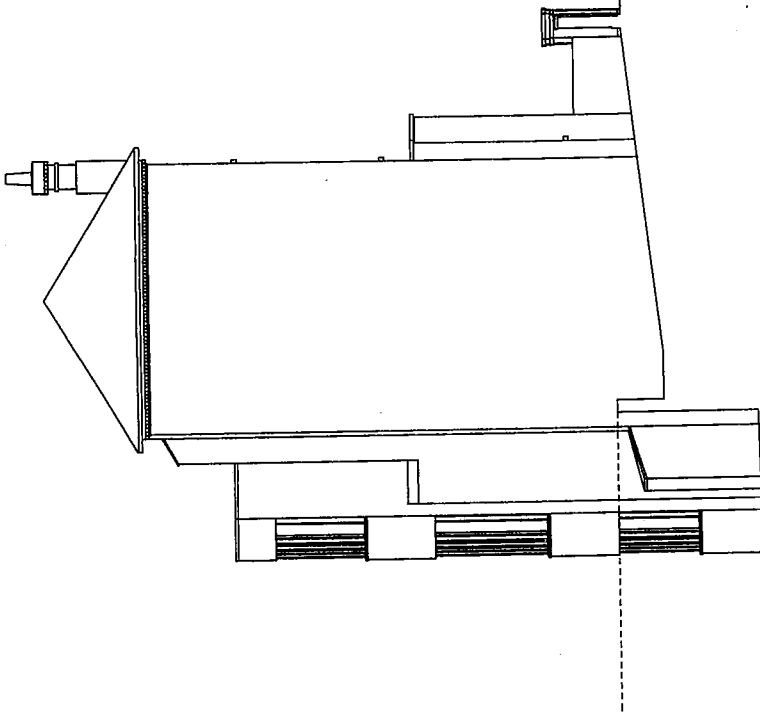

north flank elevation

1:100 at A3

RECEIVED
07 NOV 2008

TOM YOUNG ARCHITECTS

19 Bassett St
London NW5 4PC
t_020 7482 6150
m_07769 3718 502
e_tomyoung@tom.com

STAGE	feasibility = design = planning = ph = mechanical = electrical = civil = structural = other	DISCIPLINE	architectural = architectural = mechanical = electrical = other	PROJECT TITLE	15 Goyton Crescent
SERIES	0 cover sheet 1 site plan 2 elevations 3 sections 4 enlarged plans 5 details 6 schedules 7 bills of materials 8 other	DISCIPLINE	series	JOB NUMBER	0801
new side elevs		sheet	stage	SCALE	ABC 1:100
		A	02	DATE	Sept 08
				ISSUE	CLIENT
				OWNER	0801_project etc

REVISIONS

- 1 All dimensions to be checked on site
- 2 All discrepancies to be reported to architect or contract administrator immediately
- 3 Components to be fitted to the manufacturers requirements unless otherwise stated in writing
- 4 All demotions to be confirmed by SE
- 5 All work to be checked for compliance with BS 5622 & fit by contractor unless otherwise stated

Copyright for this drawing belongs to Tom Young Architects and may not be assigned to any other person or organization without TYA's written agreement

**№ 15. GAYTON CRESCENT
HAMPSTEAD.
RE-CONSTRUCTION OF DRAINS.**

APPROVED BY

7 - JUN. 1906

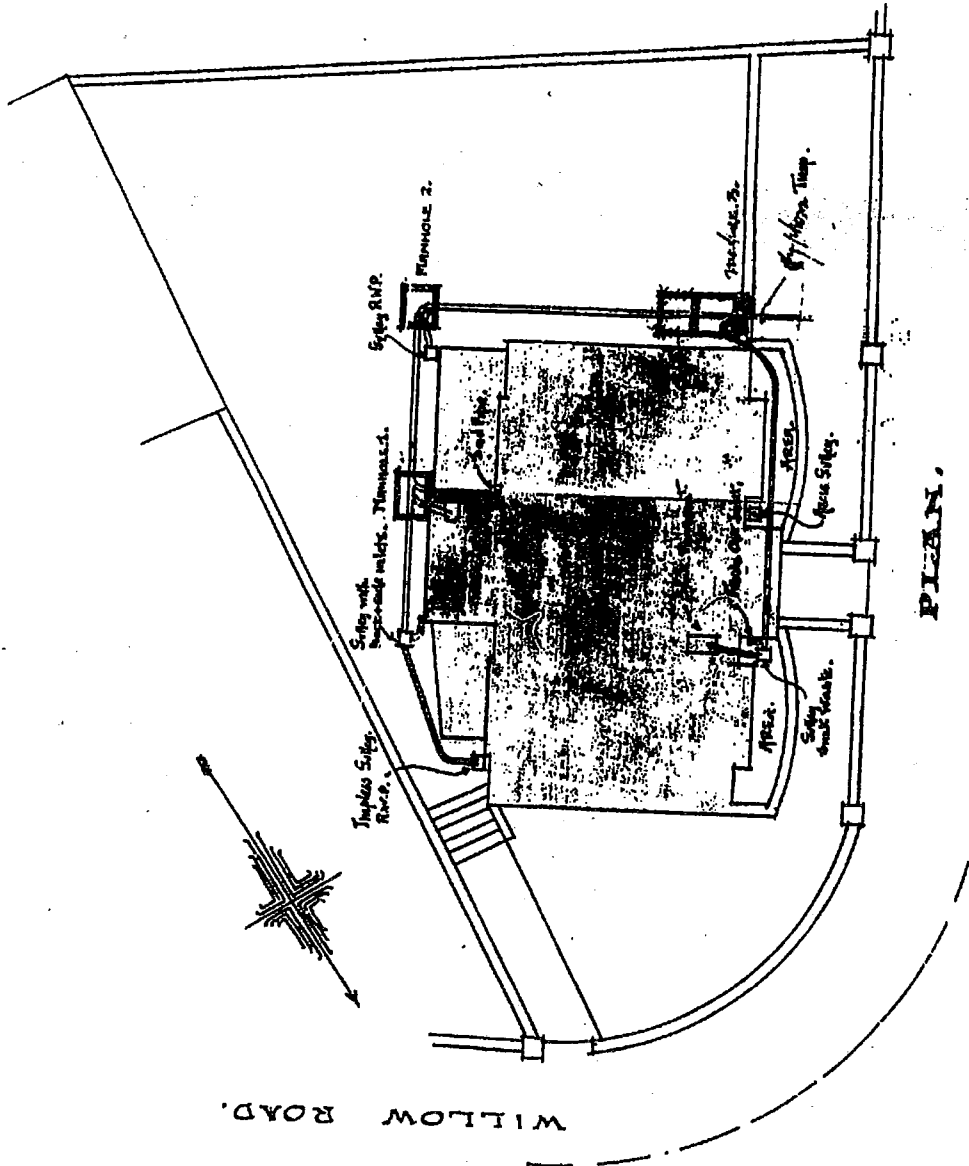

PLAN.

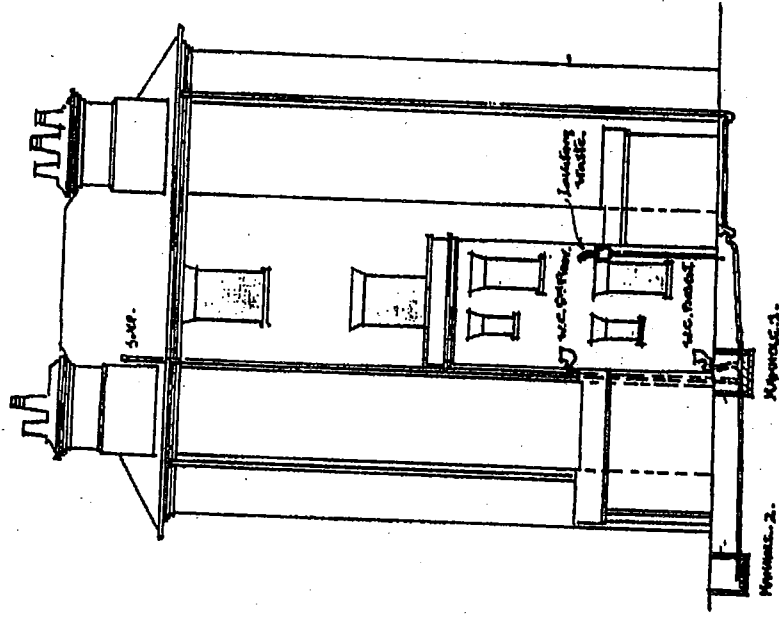

**ELEVATION
SKEWING SOIL PIPE.**

NO. 15
JUN 8 1906

APPROVED

[Signature]



GAYTON CRESCENT

Scale of Feet.