

EXISTING CROSS SECTION

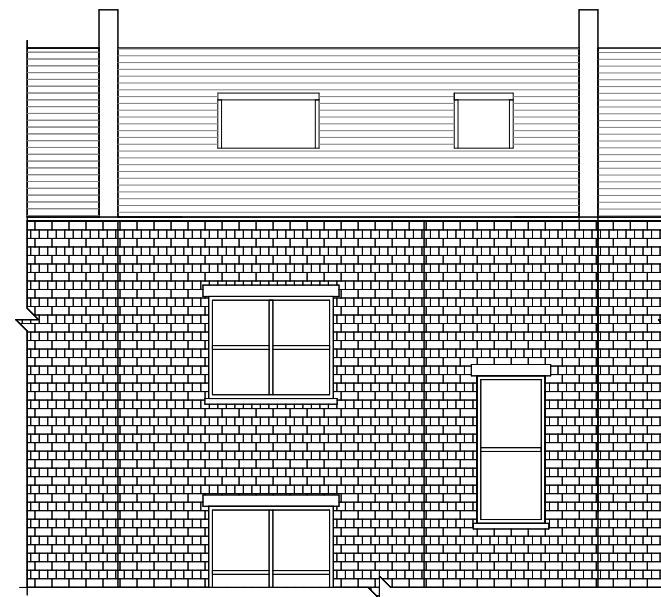

EXISTING REAR ELEVATION

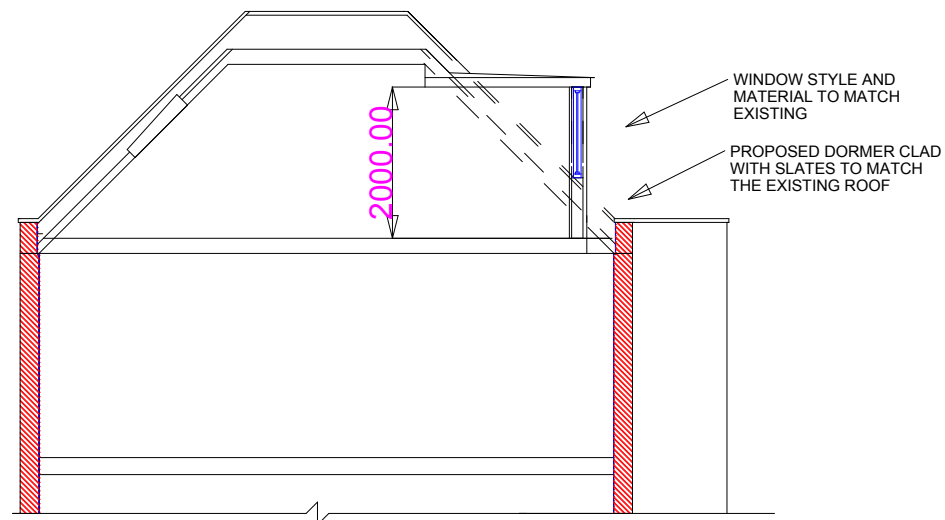

PROPOSED CROSS SECTION

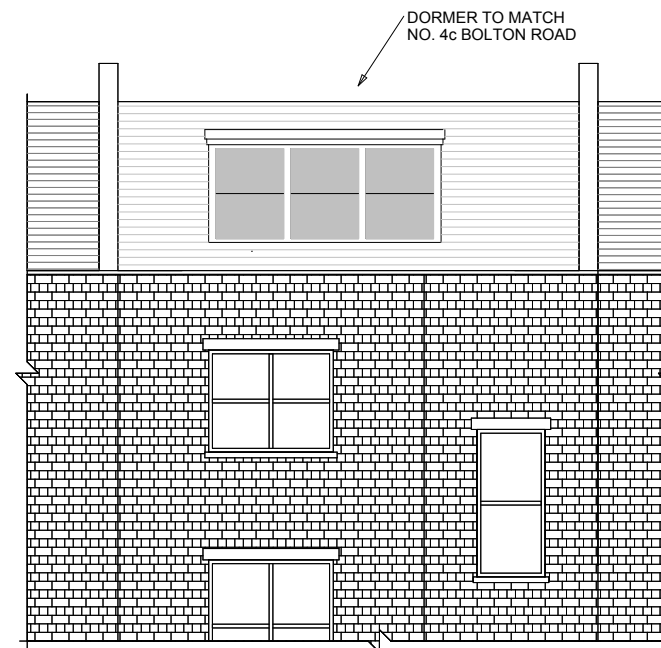

PROPOSED REAR ELEVATION

EXISTING 2ND & 3RD FLOOR PLAN

AT 3 BOLTON ROAD LONDON NW8.