

1:10 ELEVATION OF 75Ø GALVANISED COLOUR-COATED STEEL POST TOP

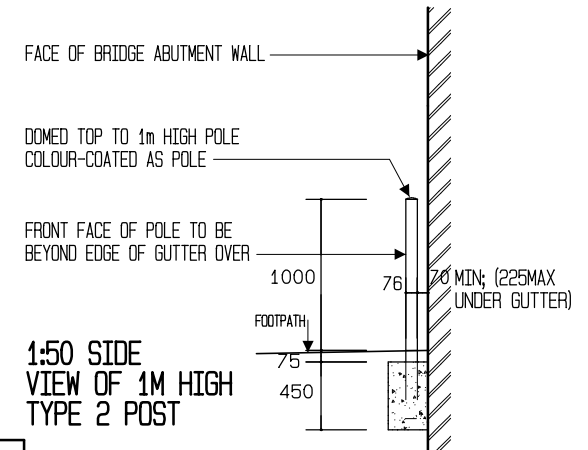

1:50 SIDE VIEW OF 1M HIGH TYPE 2 POST

76Ø GALVANISED MILD STEEL POLE, WALL THICKNESS (TBA); BOTTOM (BURIED) 1M FINISHED BITUMINOUS PAINT REMAINDER COLOUR-COATED AS NOTED ABOVE (TBA); NB POLE MAY BE ECCENTRICALLY POSITIONED WITH MIN 150 ENCASEMENT IF REQ'D

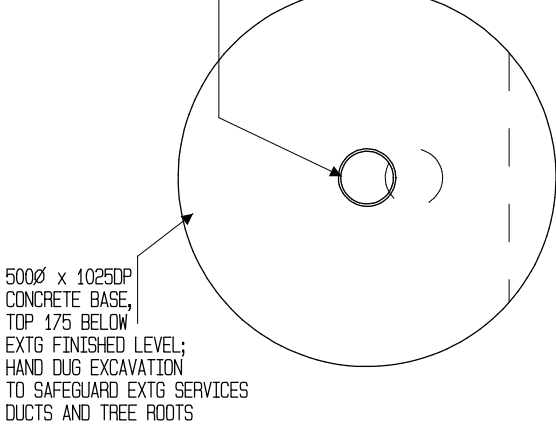

1:10 PLAN OF 500Ø CONCRETE BASE

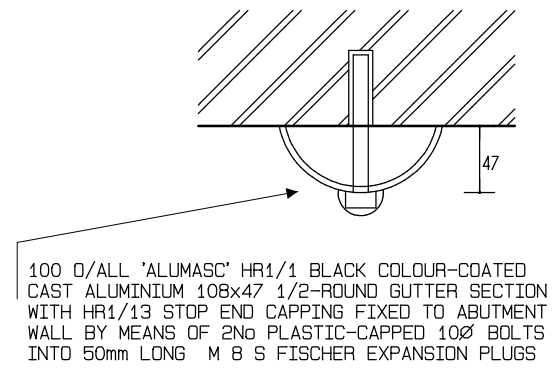

1:20 PLAN SECTION OF TYPE 1 POST

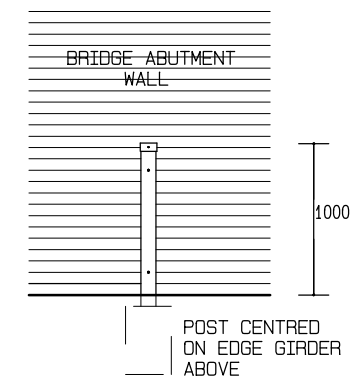

1:50 ELEVATION OF TYPE 1 POST

POLE + WIRE HEIGHTS
 ALL POLES TO BE @ 5500 ABOVE FOOTPATH LEVEL WITH 0.5MM Ø NYLON FISHING LINE SPANNING TAUT BETWEEN OVER ALL ROADS; SEE SPECIFIC LOCATION DRAWING FOR HT @ FOOTPATHS

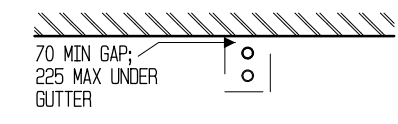

1:50 PLAN OF TYPE 2 POST

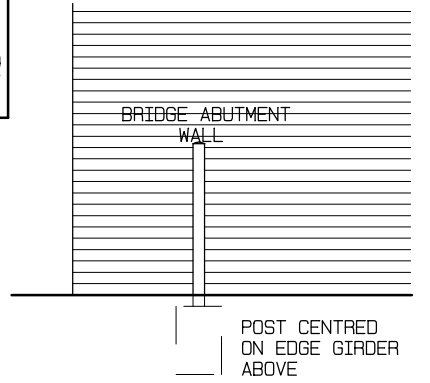

1:50 ELEVATION OF TYPE 2 POST

DRAWING REF : 870-51

BRONDESBURY ERUV POLE & WIRE AND POST DETAILS

ROSENFELDER ASSOCIATES
 Chartered Architects + Planning Consultants
 10-12 Perrins Court Hampstead LONDON NW3 (020) 7794 4425



LOCATION WITHOUT POLE

Loudoun Road, hedge and hairpin railings to side of 24 Hilgrove Road and railway bridge end pier



LOCATION WITH POLE

Loudoun Road, hedge and hairpin railings to side of 24 Hilgrove Road and railway bridge end pier with proposed pole adjacent to end of pier

DESCRIPTION:

A 5.5 grey pole at the junction of the flank railings of 24 Hilgrove Road and the north end of the railway bridge balustrade wall with a wire crossing Loudoun Road on the north side of the bridge to a matching pole on the west side of Loudoun Road.



LOCATION WITHOUT POLE

Loudoun Road north end of the railway bridge and pier and adjacent wall



LOCATION WITH POLE

Loudoun Road north end of the railway bridge and pier and adjacent wall, with pole adjacent to end of brick pier.

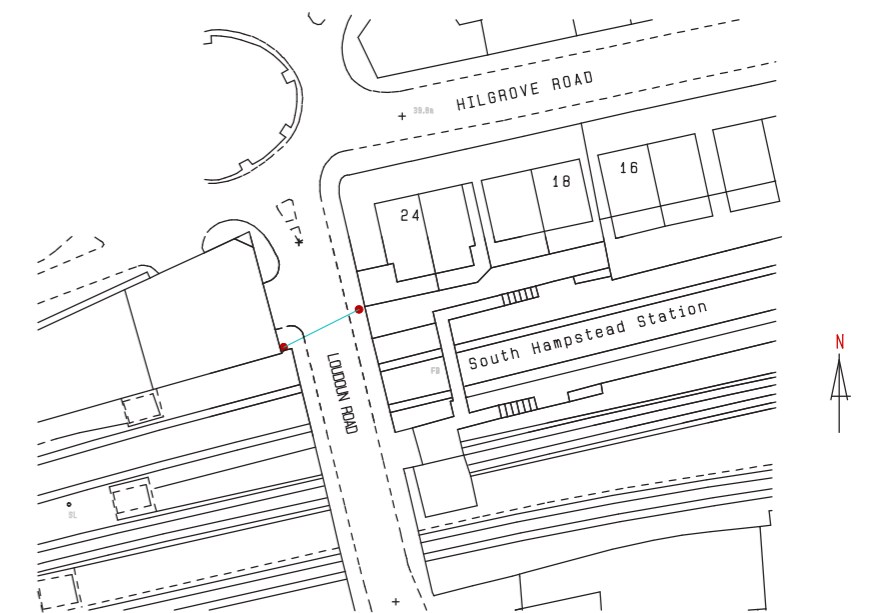

LOCATION PLAN SCALE 1:1250

BRONDESBURY ERUV - LOCATION 1 - SOUTH HAMPSTEAD STATION / LOUDOUN ROAD

DRAWING REF: 870.01

ROSENFELDER ASSOCIATES
 Chartered Architects + Planning Consultants
 10-12 Perrins Court Hampstead LONDON NW3 (020) 7794 4425



DESCRIPTION:

A 5.5m high grey pole adjacent to the flank wall of 129 Belsize Road with a wire crossing Abbey Road to a matching pole adjacent to the north abutment of the railway bridge.

LOCATION WITHOUT POLE

Abbey Road, London Stock brick wall with trellis over and adjacent brick pier and bridge balustrade wall.

LOCATION WITH POLE

Abbey Road, London Stock brick wall with trellis over and adjacent brick pier and bridge balustrade wall with pole at junction of wall and end of bridge pier.



LOCATION WITHOUT POLE

North end of railway bridge balustrade wall and adjoining hairpin railings to multi-storey car park.

LOCATION WITH POLE

North end of railway bridge balustrade wall and adjoining hairpin railings to multi-storey car park with pole at the junction of the wall and railings.

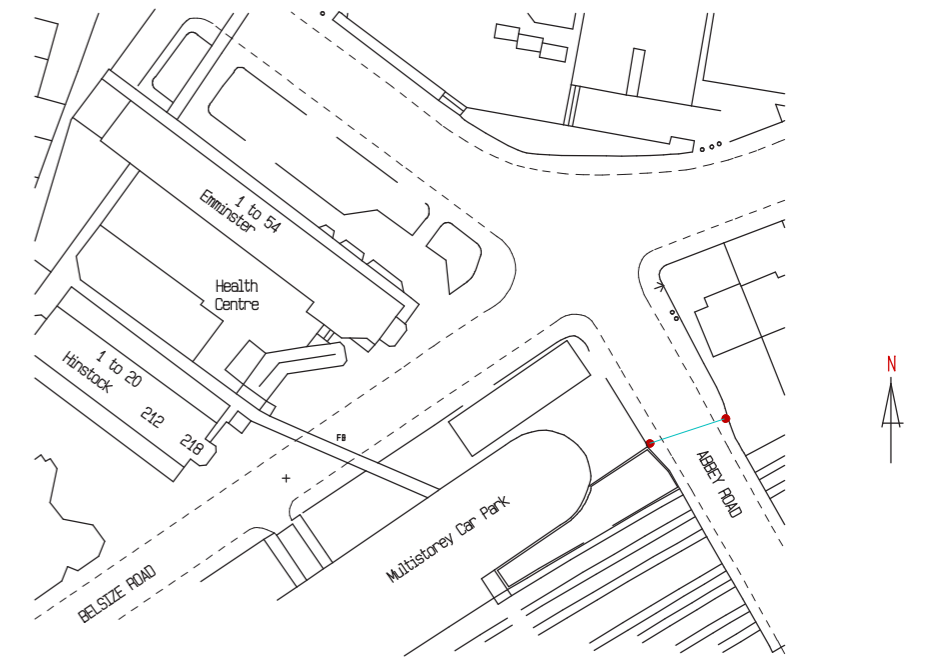

LOCATION PLAN SCALE 1:1250

BRONDESBURY ERUV - LOCATION 2 - ABBEY ROAD

DRAWING REF: 870.02

ROSENFELDER ASSOCIATES
 Chartered Architects + Planning Consultants
 10-12 Perrins Court Hampstead LONDON NW3 (020) 7794 4425



DESCRIPTION:

A 5.5m high grey pole adjacent to the bridge east balustrade abutment with a wire crossing Kilburn Priory to a white pole adjacent to north (right hand) end of 197 Belsize Road.

LOCATION WITHOUT POLE

Hoarding to side of 195 Belsize Road and north end of bridge balustrade.

LOCATION WITH POLE

Hoarding to side of 195 Belsize Road and north end of bridge balustrade with proposed pole adjacent to north end of bridge balustrade wall.



LOCATION WITHOUT POLE

Side of wall of flats at 199 Belsize Road and front of flats at 197 Belsize Road on Kilburn Priory.

LOCATION WITH POLE

Side of wall of flats at 199 Belsize Road and front of flats at 197 Belsize Road on Kilburn Priory with proposed pole adjacent to the front wall of 197 Belsize Road approx. 300mm from its north end.

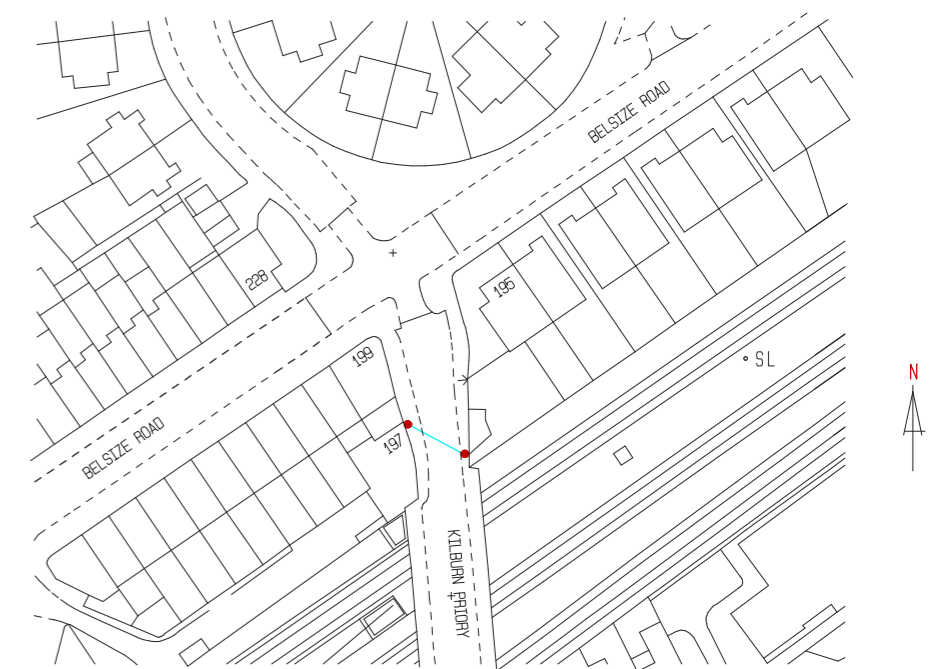

LOCATION PLAN SCALE 1:1250

BRONDESBURY ERUV - LOCATION 3 - KILBURN PRIORY

DRAWING REF: 870.03

ROSENFELDER ASSOCIATES
 Chartered Architects + Planning Consultants
 10-12 Perrins Court Hampstead LONDON NW3 (020) 7794 4425



LOCATION WITHOUT POLE
Junction between Kilburn High Street Overground Station.



LOCATION WITH POLE
Junction between Kilburn High Street Overground Station with proposed pole to left of entrance.



LOCATION WITHOUT POLE
WPS estate agents on Kilburn High Road.



LOCATION WITH POLE
WPS estate agents on Kilburn High Road with proposed

DESCRIPTION:

5.5m high pole coloured grey (RAL 7035) adjacent to party wall pier between Kilburn High Road Station and Tasty Kebab to the left, with wire crossing Kiburn High Road to a 6m high pole coloured grey (RAL 3035) adjacent to the right hand pier of WPS estate agents, between 4 and 6 Kilburn Bridge.

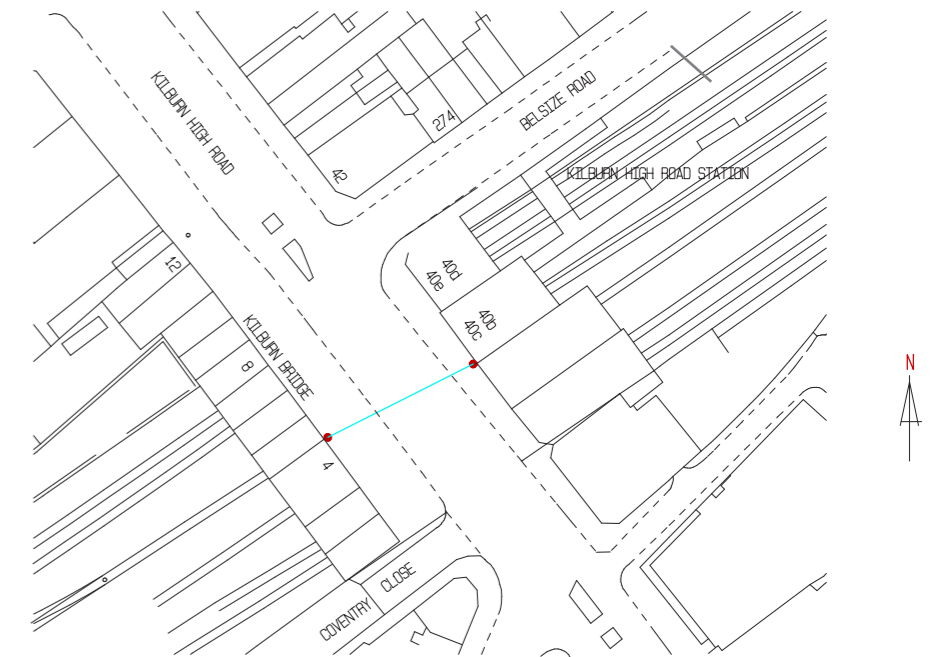

LOCATION PLAN SCALE 1:1250

BRONDESBURY ERUV - LOCATION 4 - KILBURN HIGH ROAD

DRAWING REF: 870.04

ROSENFELDER ASSOCIATES
Chartered Architects + Planning Consultants
10-12 Perrins Court Hampstead LONDON NW3 (020) 7794 4425



DESCRIPTION:

A 5.5m high grey pole adjacent to the north end of the bridge balustrade on the east side of the bridge with wire crossing Salisbury Road to a matching pole adjacent to the north end of the bridge balustrade opposite.

LOCATION WITHOUT POLE

North end of frontage of Queen's Park station with adjacent railway bridge balustrade wall on east side of Salisbury Road.

LOCATION WITH POLE

North end of frontage of Queen's Park station with adjacent railway bridge balustrade wall on east side of Salisbury Road with proposed pole adjacent to bridge balustrade wall approx 300mm beyond overhanging eaves (to avoid low level services).



LOCATION WITHOUT POLE

North end of railway balustrade wall opposite Queen's Park station on west side of Salisbury Road with fence wall adjacent.

LOCATION WITH POLE

North end of railway balustrade wall opposite Queen's Park station on west side of Salisbury Road with fence wall adjacent to the north end of the bridge balustrade wall.

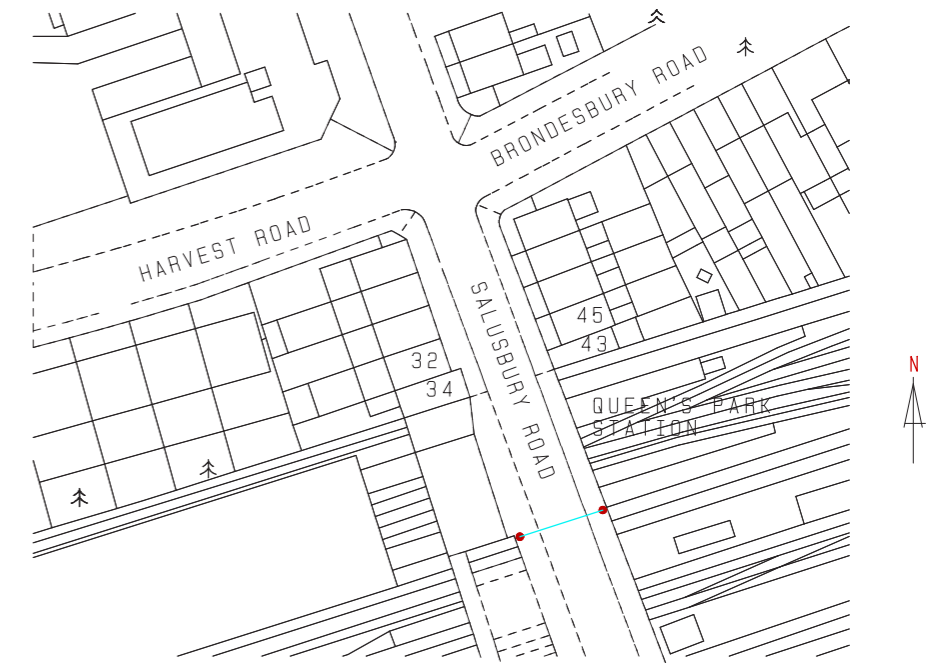

LOCATION PLAN SCALE 1:1250

BRONDESBURY ERUV - LOCATION 5 - SALUSBURY ROAD

DRAWING REF: 870.05

ROSENFELDER ASSOCIATES
 Chartered Architects + Planning Consultants
 10-12 Perrins Court Hampstead LONDON NW3 (020) 7794 4425



LOCATION WITHOUT POLE

North end of railway bridge on the east side of Chamberlayne Road with adjoining shop property at number 37.



LOCATION WITH POLE

North end of railway bridge on the east side of Chamberlayne Road with adjoining shop property at number 37 with proposed pole adjacent to centre of right hand pier to shop at 37 Chamberlayne Road

DESCRIPTION:

A 5.5m high grey pole adjacent to the south (right hand) pier of the Yours 'N' Mine restaurant at 37 Chamberlayne Road with a wire crossing Chamberlayne Road to a matching pole adjacent to the north end raised pier of the bridge balustrade opposite.



LOCATION WITHOUT POLE

North end of railway bridge on the west side of Chamberlayne Road with the adjoining shop property at number 52



LOCATION WITH POLE

North end of railway bridge on the west side of Chamberlayne Road with the adjoining shop property at number 52 with proposed pole approx 250mm from north end of the railway balustrade wall end pier (to avoid services).

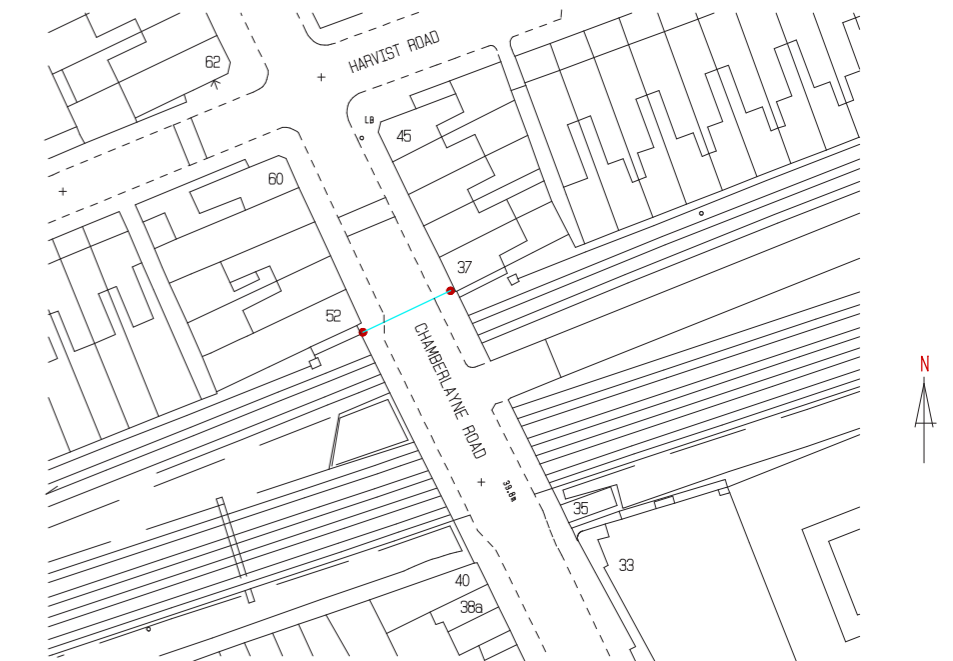

LOCATION PLAN SCALE 1:1250

BRONDESBURY ERUV - LOCATION 6 - CHAMBERLAYNE ROAD

DRAWING REF: 870.06

ROSENFELDER ASSOCIATES
 Chartered Architects + Planning Consultants
 10-12 Perrins Court Hampstead LONDON NW3 (020) 7794 4425



DESCRIPTION:

A 5.5m high grey pole adjacent the corner post of the galvanised steel paling fence with a wire crossing Harrow Road to a matching pole adjacent to the fence to the left hand side of the advertising hoarding opposite on the south side of Harrow Road.

LOCATION WITHOUT POLE

Green open space at the junction of College Road and Harrow Road showing the galvanised palisade steel fence.

LOCATION WITH POLE

Green open space at the junction of College Road and Harrow Road showing the galvanised palisade steel fence with proposed pole adjacent to return angle fence post.



LOCATION WITHOUT POLE

Advertising hoarding in front of brick wall on opposite, south side of Harrow Road and the fence wall adjacent.

LOCATION WITH POLE

Advertising hoarding in front of brick wall on opposite, south side of Harrow Road and the fence wall adjacent with proposed pole at rear of the public footpath approx 600mm from the end of the wall beyond the left hand end of the advertising hoarding.

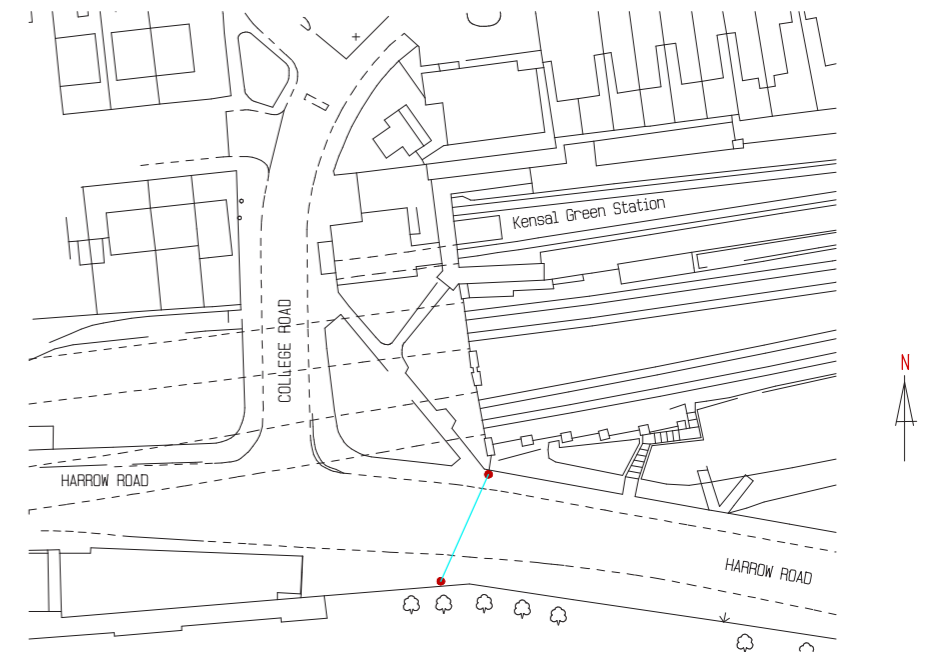

LOCATION PLAN SCALE
1:1250

DRAWING REF: 870.07

BRONDESBURY ERUV - LOCATION 7 - HARROW ROAD

ROSENFELDER ASSOCIATES
Chartered Architects + Planning Consultants
10-12 Perrins Court Hampstead LONDON NW3 (020) 7794 4425



DESCRIPTION:

A 5.5m high grey pole adjacent to the west end of the south wall on Waldo Road with a wire crossing Scrubs Lane diagonally to a matching pole adjacent to the south end of the advertising hoarding opposite on the west side of Scrubs Lane.

LOCATION WITHOUT POLE

Junction between Waldo Road and Scrubs Lane as existing.

LOCATION WITH POLE

Junction between Waldo Road and Scrubs Lane with proposed pole at north end of railway bridge balustrade wall.



LOCATION WITHOUT POLE

Hoarding on west side of Scrubs Lane as existing.

LOCATION WITH POLE

Hoarding on west side of Scrubs Lane with proposed pole to the right hand side of the advertising hoarding.

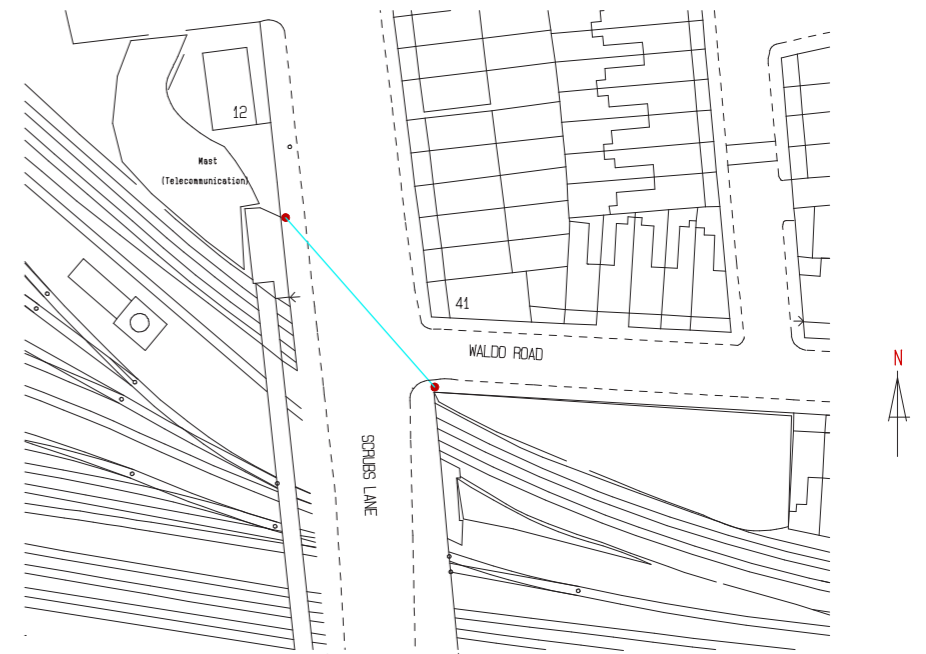

LOCATION PLAN SCALE 1:1250

DRAWING REF: 870.08

BRONDESBURY ERUV - LOCATION 8 - SCRUBS LANE

ROSENFELDER ASSOCIATES
 Chartered Architects + Planning Consultants
 10-12 Perrins Court Hampstead LONDON NW3 (020) 7794 4425



LOCATION WITHOUT POLE

Railway bridge balustrade wall and galvanised steel palisade wall, with notice board on the east side of Station Road (north of Old Oak Lane).



LOCATION WITH POLE

Railway bridge balustrade wall and galvanised steel palisade wall, with notice board on the east side of Station Road (north of Old Oak Lane) with the proposed pole 300mm to left of notice board.

DESCRIPTION:

A 5.5m high grey pole adjacent to the bridge balustrade wall between the lamp post and notices hoarding with a wire crossing Station Road adjacent to the galvanised paling fence opposite.



LOCATION WITHOUT POLE

Galvanised steel palisade fence to the north of the railway bridge balustrade wall on the west side of Station Road (north of Old Oak Lane).



LOCATION WITH POLE

Galvanised steel palisade fence to the north of the railway bridge balustrade wall on the west side of Station Road (north of Old Oak Lane) with proposed post adjacent to palisade fence post to left of third panel.

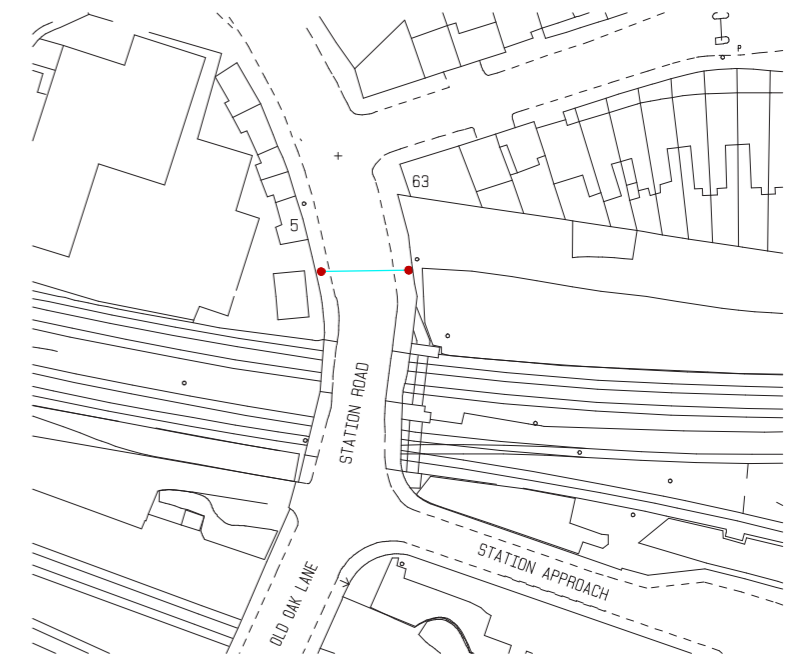

LOCATION PLAN SCALE 1:1250

DRAWING REF: 870.09

BRONDESBURY ERUV - LOCATION 9 - STATION ROAD

ROSENFELDER ASSOCIATES
 Chartered Architects + Planning Consultants
 10-12 Perrins Court Hampstead LONDON NW3 (020) 7794 4425



LOCATION WITHOUT POLE
East side of south abutment wall of railway bridge over Acton Lane.



LOCATION WITH POLE
East side of south abutment wall of railway bridge over Acton Lane with proposed 1 - metre high black pole 50mm from face of wall, centered under east edge beam of bridge over.



LOCATION WITHOUT POLE
East side of north abutment wall of railway bridge over Acton Lane.



LOCATION WITH POLE
East side of north abutment wall of railway bridge over Acton Lane with proposed 1 - metre high black pole 50mm from face of wall, centered under east edge beam of bridge over.

DESCRIPTION:

A 1 metre high black pole approx 100mm from the face of the south and north abutments of the bridge immediately beneath the east edge beam of the bridge.

(Pole shown grey for visibility on drawing)

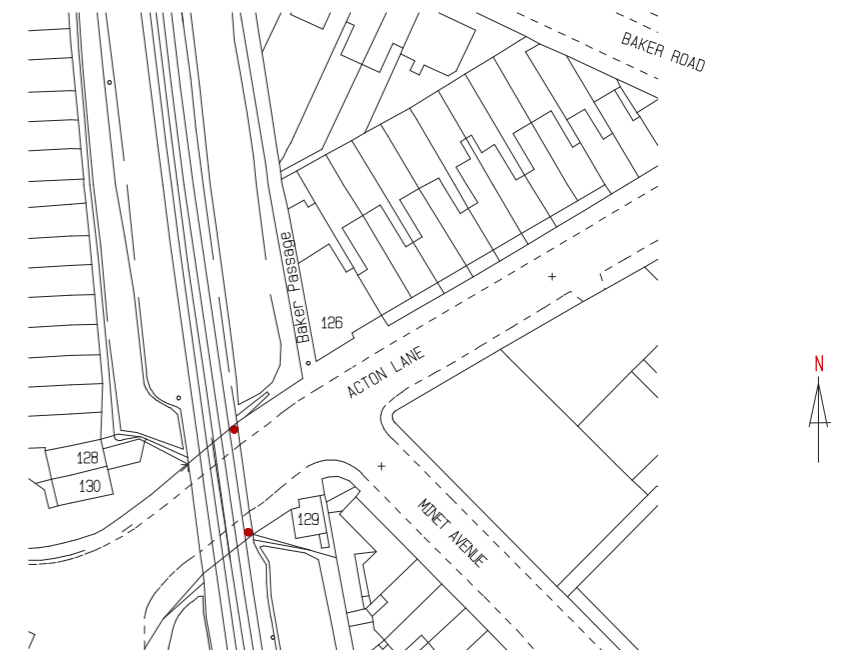

LOCATION PLAN SCALE 1:1250

BRONDESBURY ERUV - LOCATION 10 - ACTON LANE

DRAWING REF: 870.10

ROSENFELDER ASSOCIATES
Chartered Architects + Planning Consultants
10-12 Perrins Court Hampstead LONDON NW3 (020) 7794 4425



LOCATION WITHOUT POLE
Junction of Park Road and Craven Park.

LOCATION WITH POLE
Junction of Park Road and Craven Park with proposed pole at rear of public footpath centred on the first brick pier on the Park Road return side wall of 18 Craven Park.



LOCATION WITHOUT POLE
North side of Craven Park showing numbers 13 and 15.

LOCATION WITH POLE
North side of Craven Park showing numbers 13 and 15 with proposed pole at rear of public footpath on centre line of pier.

DESCRIPTION:

A 5.5 metre high grey pole adjacent to the first pier of the garden fence wall of 18 Craven Park along Park Road with a wire crossing Craven Park to a matching pole adjacent to the pier between 13/15 Craven Park.

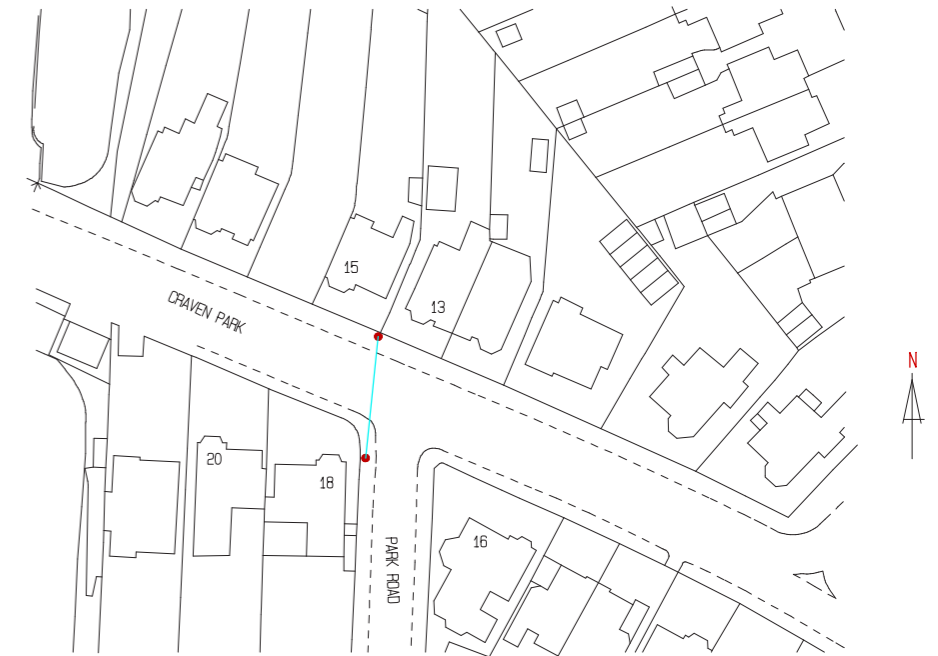

LOCATION PLAN SCALE 1:1250

DRAWING REF: 870.11

BRONDESBURY ERUV - LOCATION 11 - CRAVEN PARK

ROSENFELDER ASSOCIATES
Chartered Architects + Planning Consultants
10-12 Perrins Court Hampstead LONDON NW3 (020) 7794 4425



DESCRIPTION:

A 5.5 metre high grey pole adjacent to the left hand (east) pier of the gates adjacent to the flats (Bridge Court) with a wire crossing Craven Park to a matching pole adjacent to the right hand (east) end of the bridge balustrade wall.

LOCATION WITHOUT POLE

West flank of Bridge Court on the south side of Craven Park.

LOCATION WITH POLE

West flank of Bridge Court on the south side of Craven Park with the proposed pole adjacent to the fence post of the gates to the driveway into the land to the west of Bridge Court.

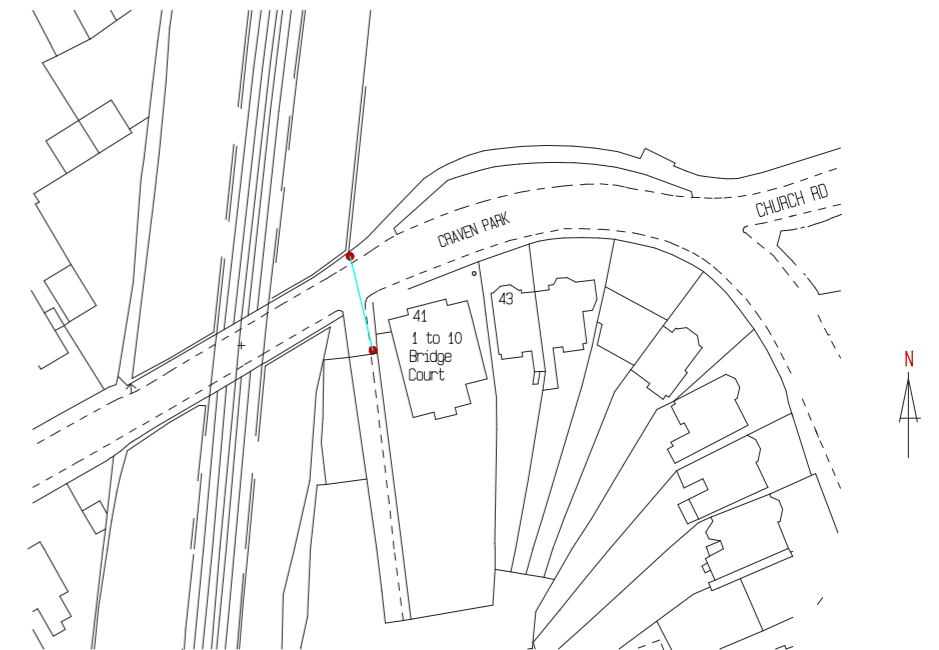

LOCATION WITHOUT POLE

Junction of railway bridge balustrade wall and the west end of the fence of the new flats development on the north side of Craven Park.

LOCATION WITH POLE

Junction of railway bridge balustrade wall and the west end of the fence of the new flats with the proposed pole immediately to the right hand end of the railway bridge balustrade pier.

LOCATION PLAN SCALE 1:1250

BRONDESBURY ERUV - LOCATION 12 - CRAVEN PARK

DRAWING REF: 870.12

ROSENFELDER ASSOCIATES
 Chartered Architects + Planning Consultants
 10-12 Perrins Court Hampstead LONDON NW3 (020) 7794 4425



LOCATION WITHOUT POLE
South abutment of railway bridge.



LOCATION WITH POLE
South abutment of railway bridge with proposed pole under east girder of bridge over.



LOCATION WITHOUT POLE
North abutment of railway bridge.



LOCATION WITH POLE
North abutment of railway bridge with proposed pole under east edge girder of bridge over.

DESCRIPTION:

A 1 metre high pole 25 mm from the left hand (south) and right hand (north) abutment walls of the bridge immediately beneath the east edge girder of the bridge above. A clear Perspex infill panel to be fixed to the footpath balustrade railing under the south edge girder of the bridge above.

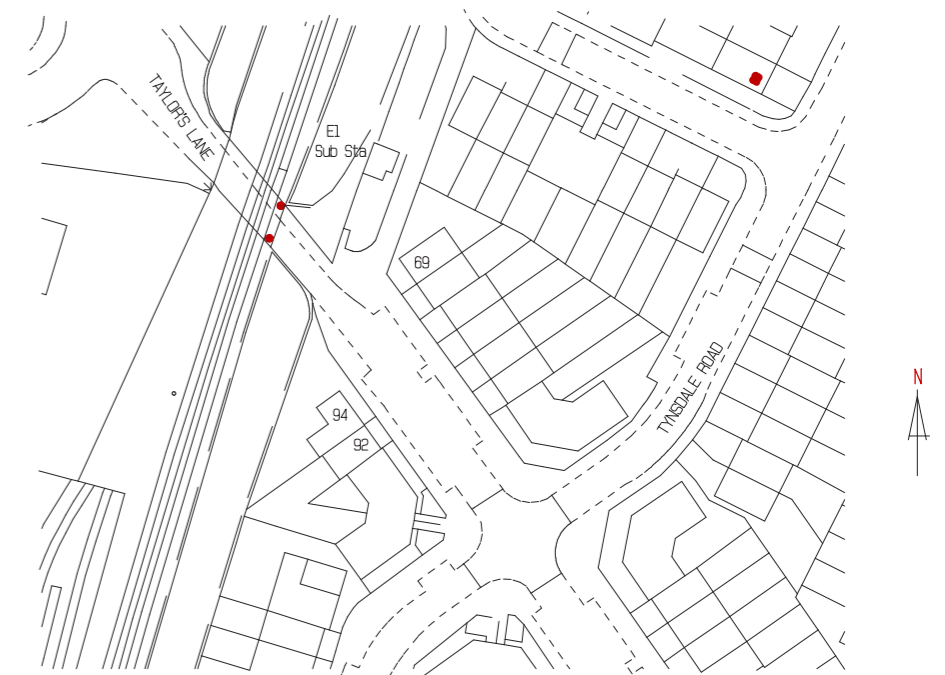

LOCATION PLAN SCALE 1:1250

BRONDESBURY ERUV - LOCATION 13 - TAYLOR'S LANE BRIDGE

DRAWING REF: 870.13

ROSENFELDER ASSOCIATES
Chartered Architects + Planning Consultants
10-12 Perrins Court Hampstead LONDON NW3 (020) 7794 4425