

All frames and elements are of white painted hardwood

Slimline double glazed units of an overall thickness of 11mm



SAMPLE PHOTOGRAPH
SCALE 1 - 1

Jamb Detail

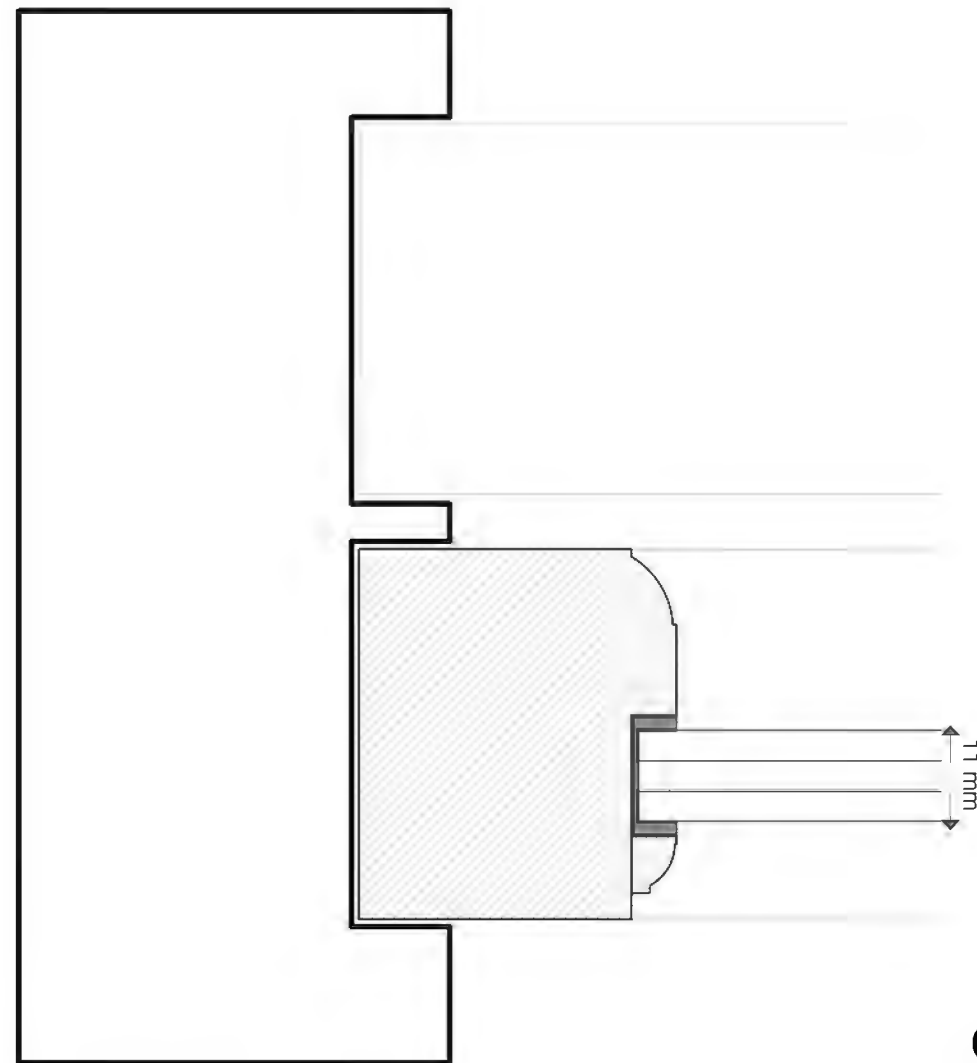

TYPICAL WINDOW DETAIL
SCALE 1 - 1

Glazing bar detail

INSIDE

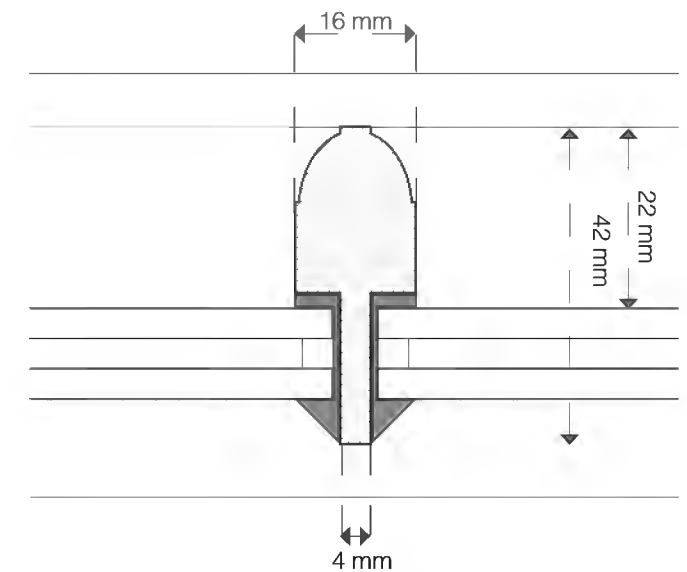

OUTSIDE

TYPICAL WINDOW DETAIL
SCALE 1 - 1

Client:
Blarney Land Services LTD
Project:
1 Templewood Gardens
London NW3 7XB
Location:
Window Details

BLARNEY Land Services Ltd

Drawn:	Information	Check:	1:25
Scale:	NTS	Date:	JUNE 2014
Drawn by:	175_PL_10	Revision:	