

This drawing is the property of Vodafone and must not be copied or reproduced in full or in part without express written permission. DO NOT SCALE. Use figured dimensions only. All dimensions to be verified on site prior to commencing construction.

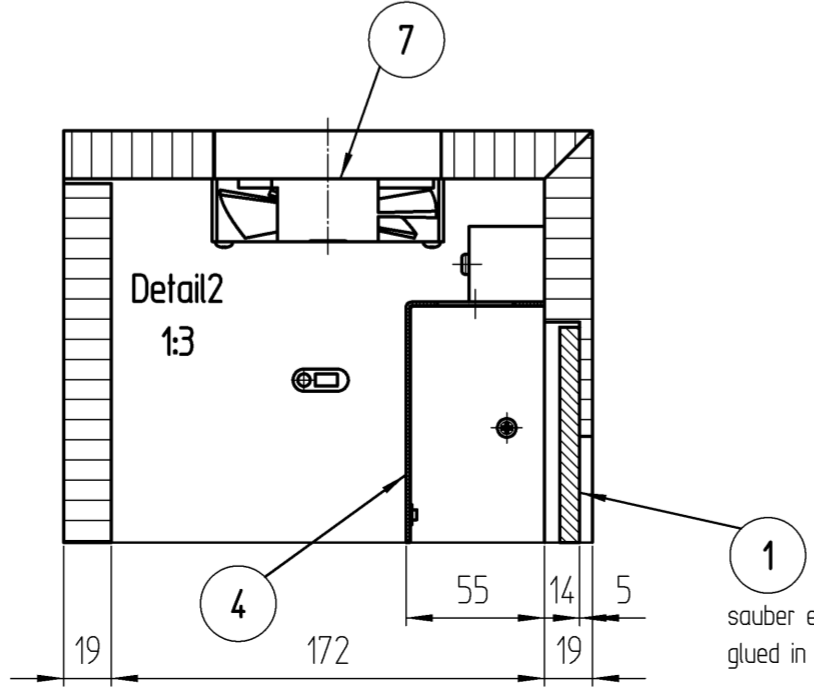

14	round head wood screw 3.5x35	75083593	14		7996	zinc plated
3,2lfm	foam tape 15x2mm	61681360	13			Maagtechnic 10010848
1	supply cable Schuko GST18	61287584	12			Bachmann 375.003
1	STEP socket strip 4xSchuko	61287583	11			Bachmann 336.604
1	cable clamp	61287582	10			Conrad 531383-05
1	Schuko-cable 2m	61287581	9			Bachmann 301.274
1	4-wire terminal unit	61287580	8			WAGO 862-1503
3	fan 92x92x25	61287562	7			Sunon MA2092-HVL
2	castor D35	61261884	6			Tente 5920U01035S70-10x15
2	TV-Back Bracket cpl.	174042	5			
1	Light Box cpl.	174039	4			
1	Carcass	174038	3			
1	Wall Hinge cpl.	174035	2			
1	Acrylic Panel cpl.	171659	1			
Piece	Designation/Description	Drawing/Mat.-Nr.	Pos	Material	DIN/VBN	Remark

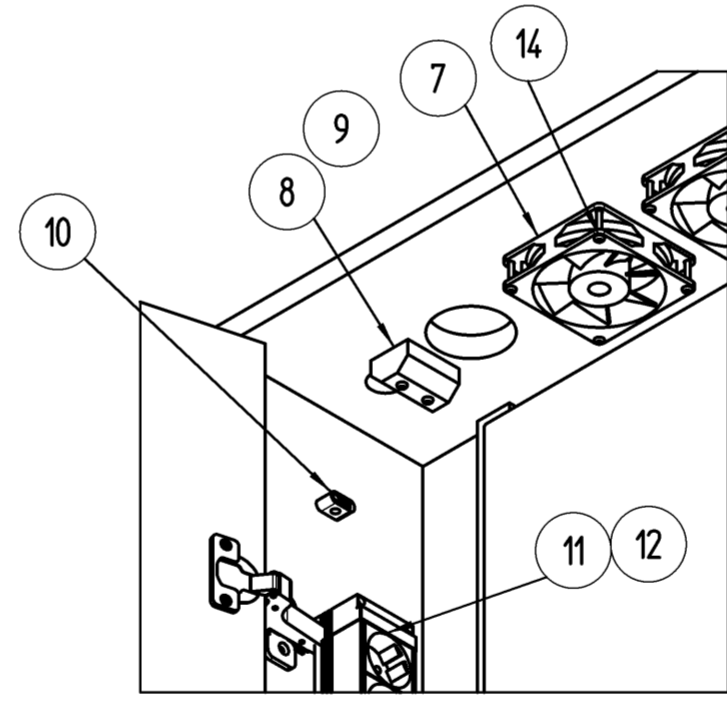
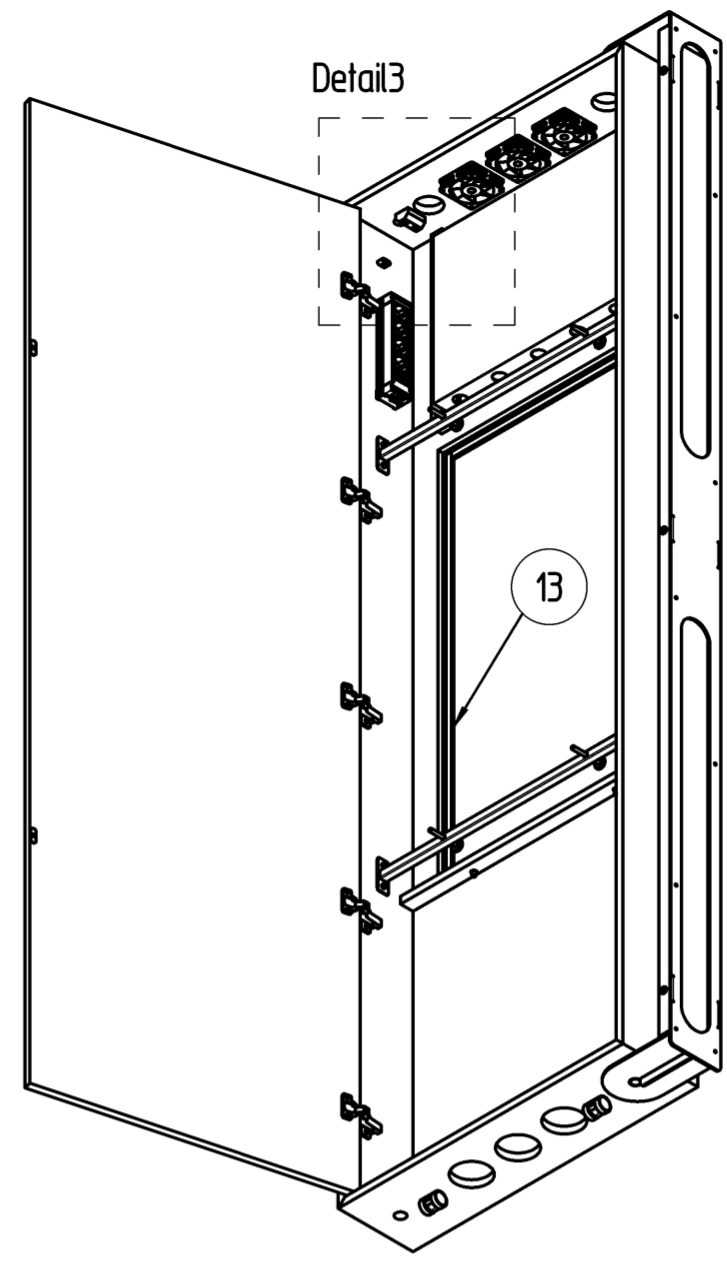
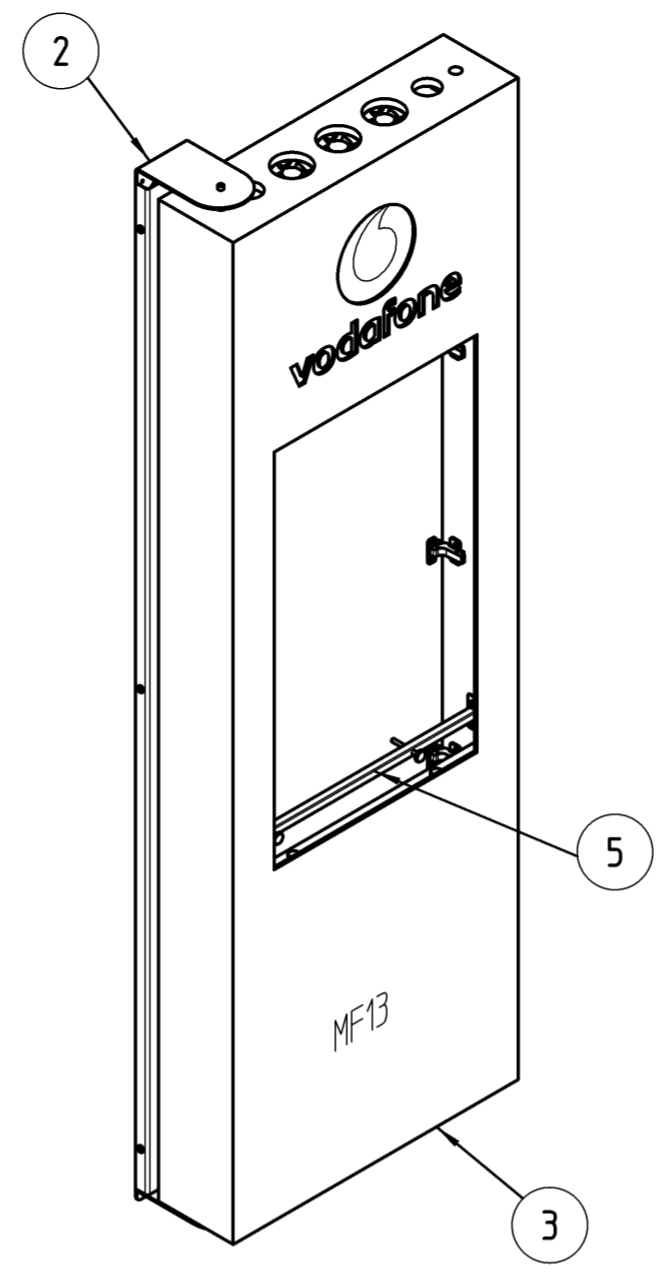
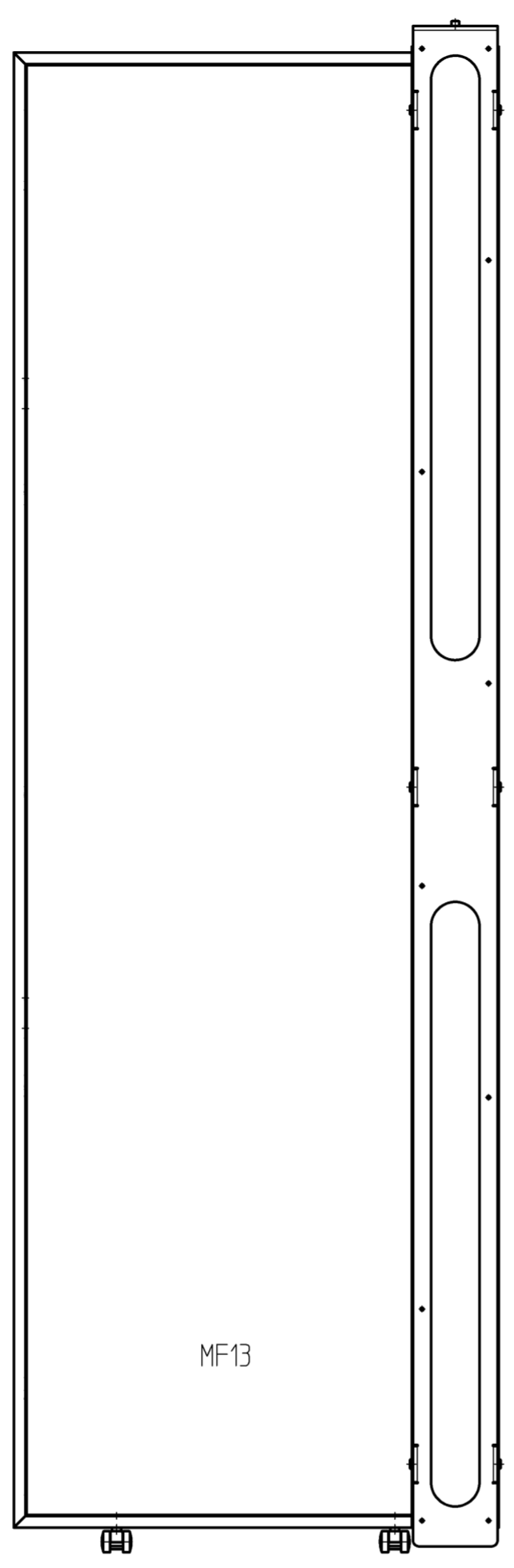
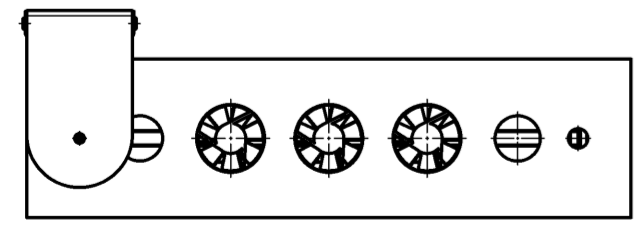
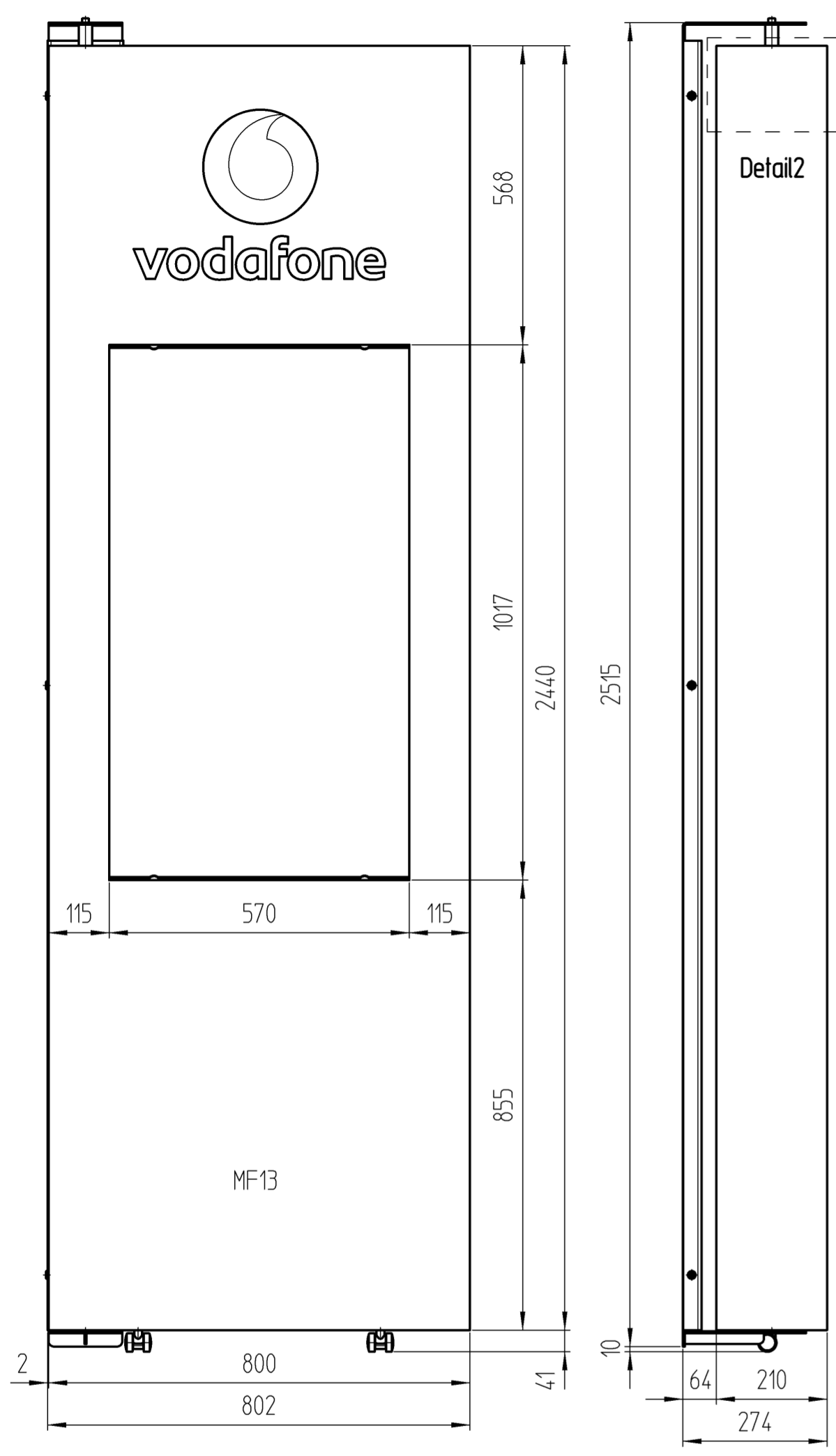

**NOTES:**  
 C: various changes  
 30.07.13 Keppler  
 D: carcass changed  
 30.08.13 Keppler

**DRAWING TITLE:**  
 Promo Fin  
 Timber

**SCALE:** 1:10  
**SHEET SIZE:** To Scale A2

**DRAWN BY:** Keppler  
**DATE:** 19.07.13

**SERIES NO:**  
**DWG NO:** ST 174-00 46

**DWG NO:** 174-034  
**REVISION:** D

WORK

This drawing is the property of Vodafone and must not be copied or reproduced in full or in part without express written permission. DO NOT SCALE. Use figured dimensions only. All dimensions to be verified on site prior to commencing construction.

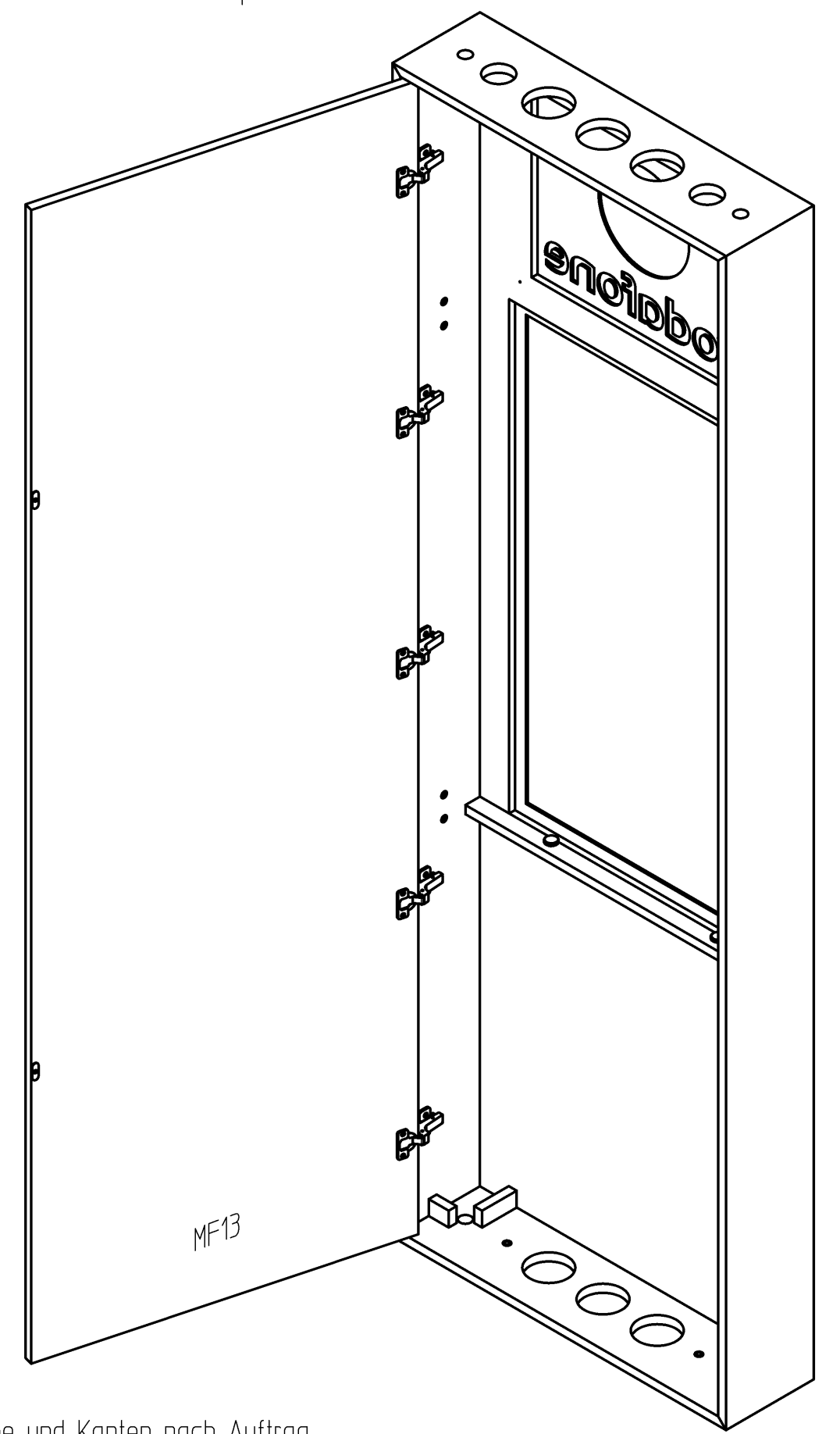
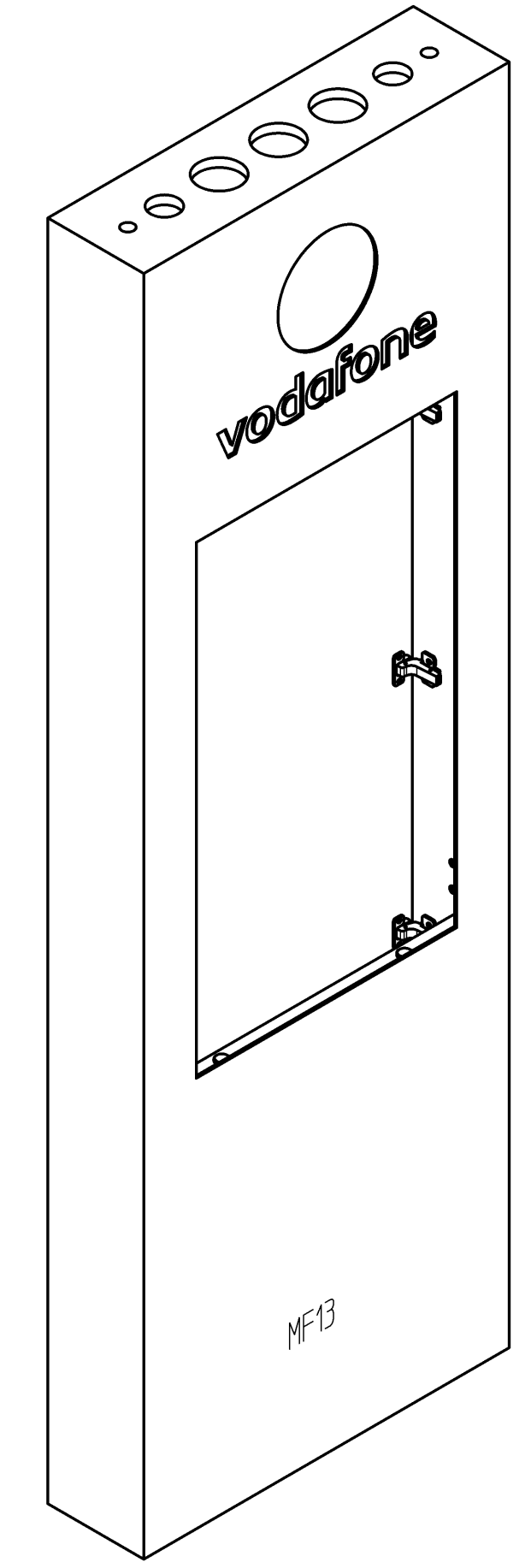
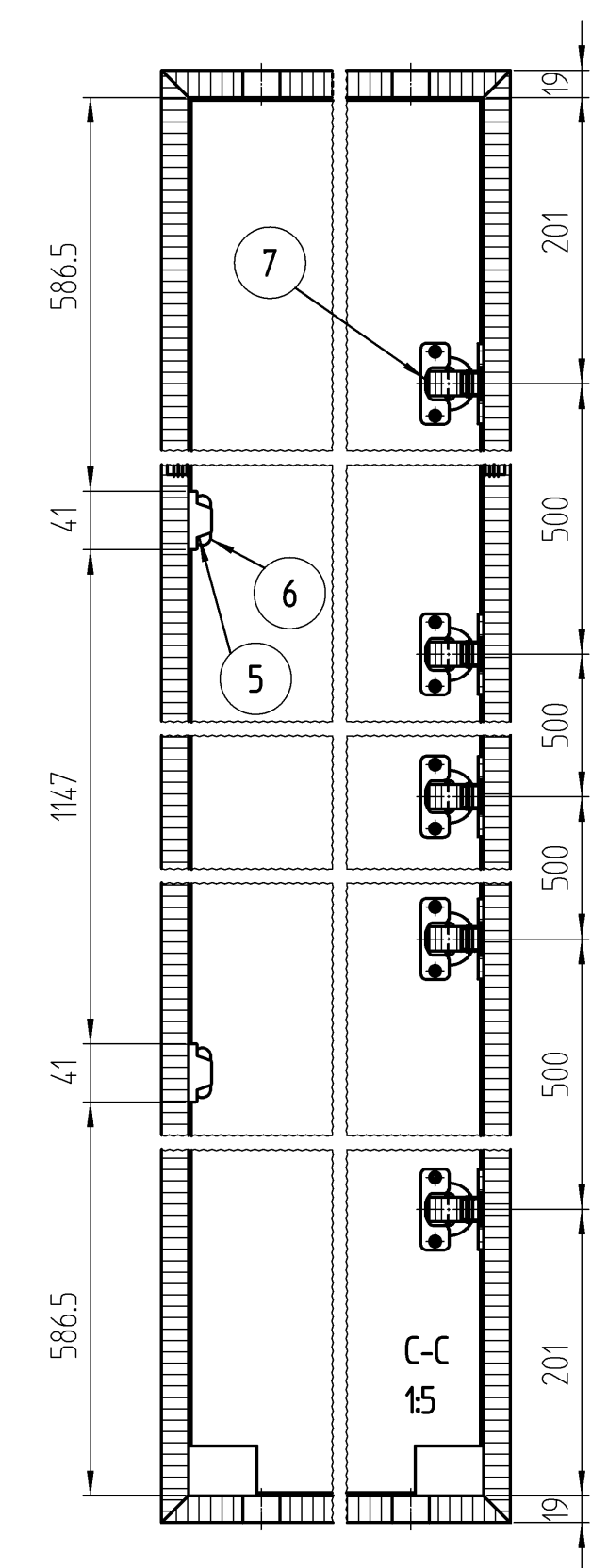
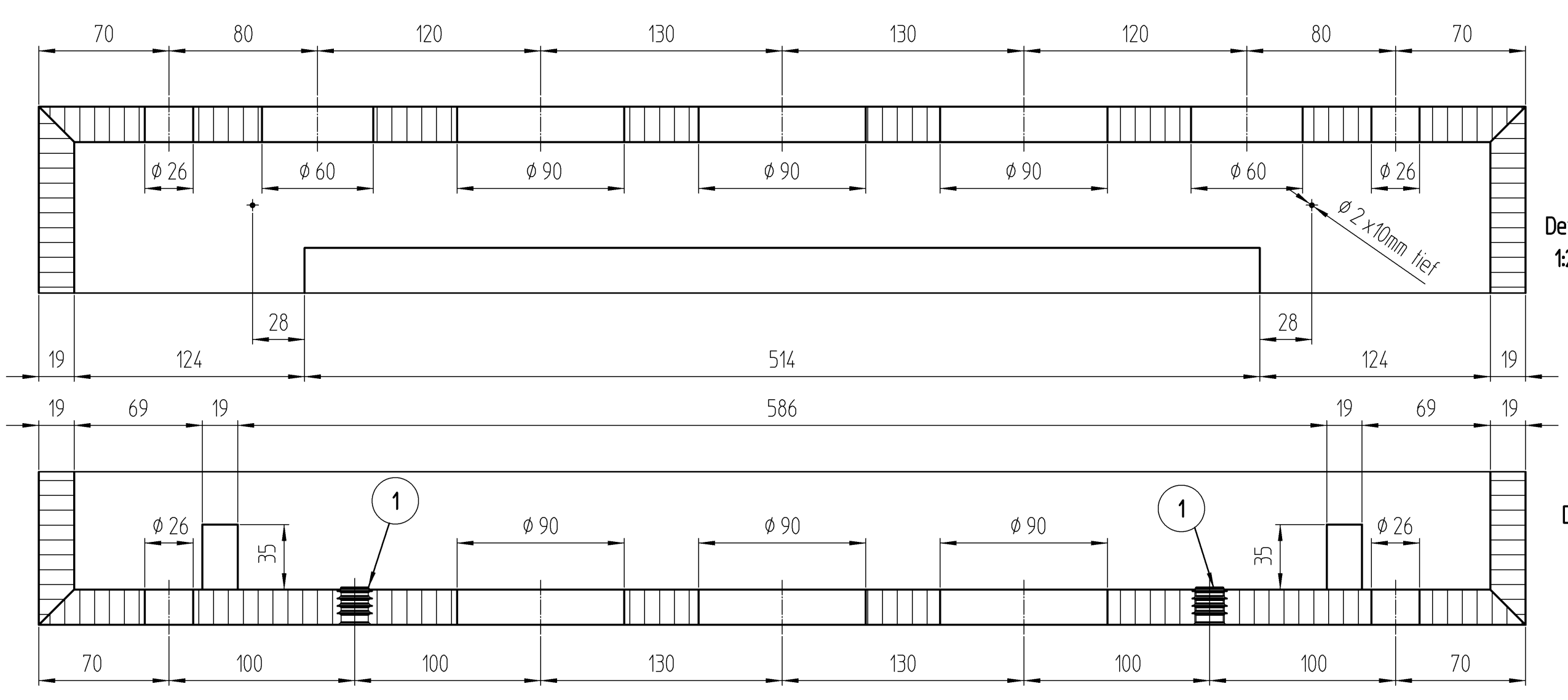
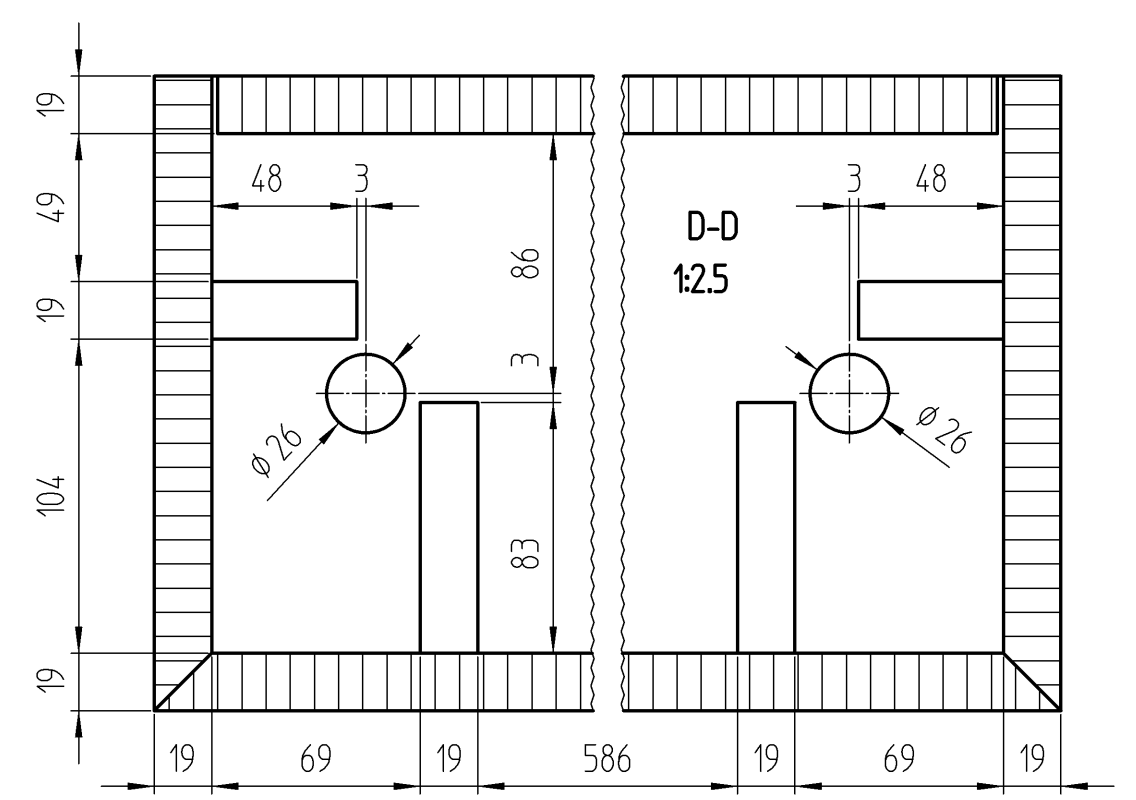
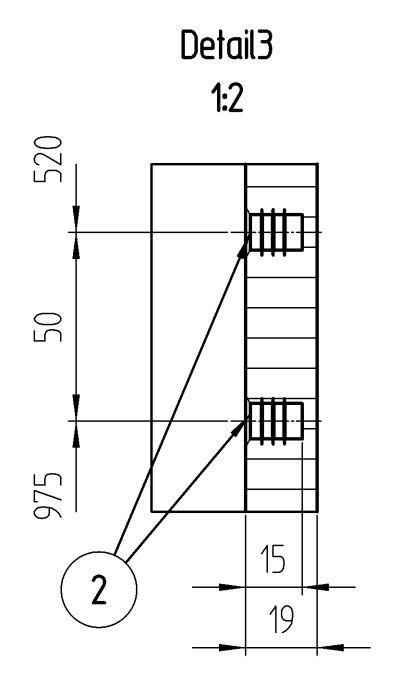
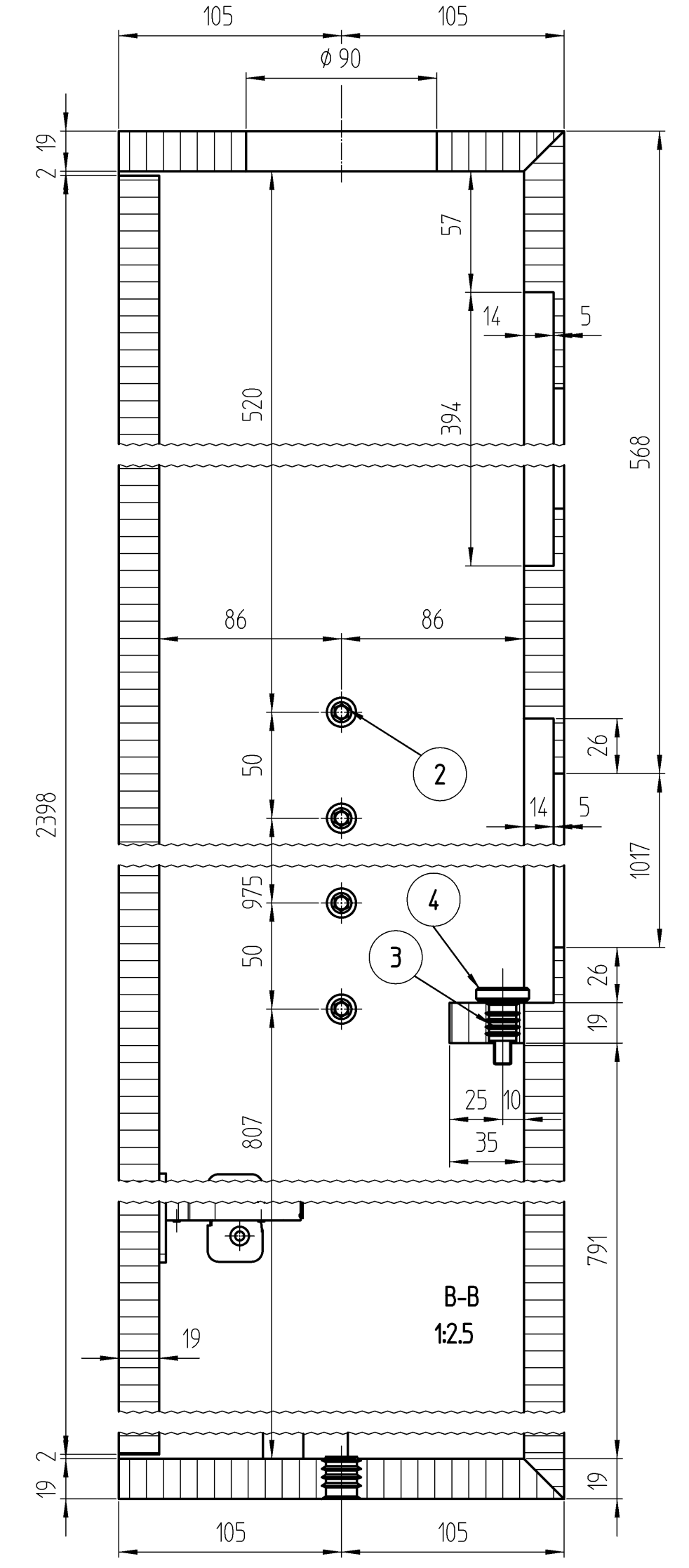
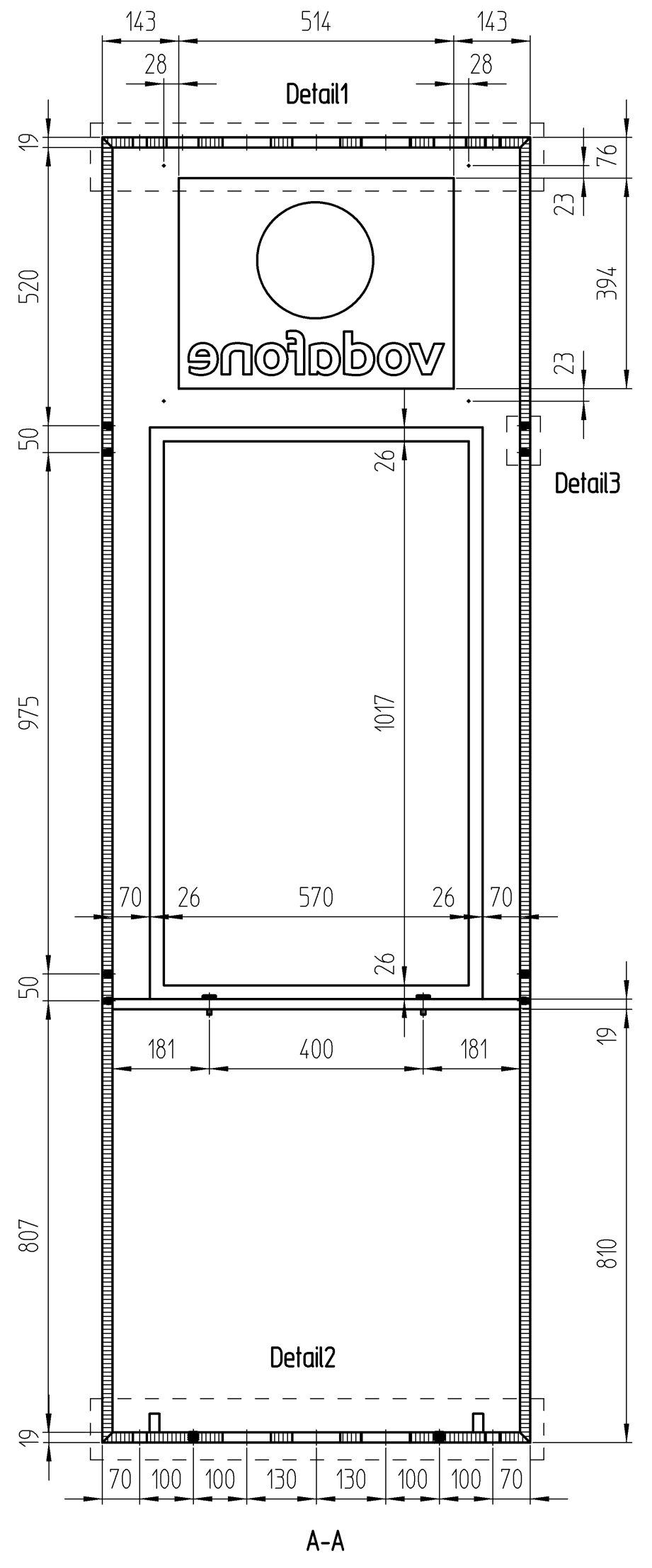
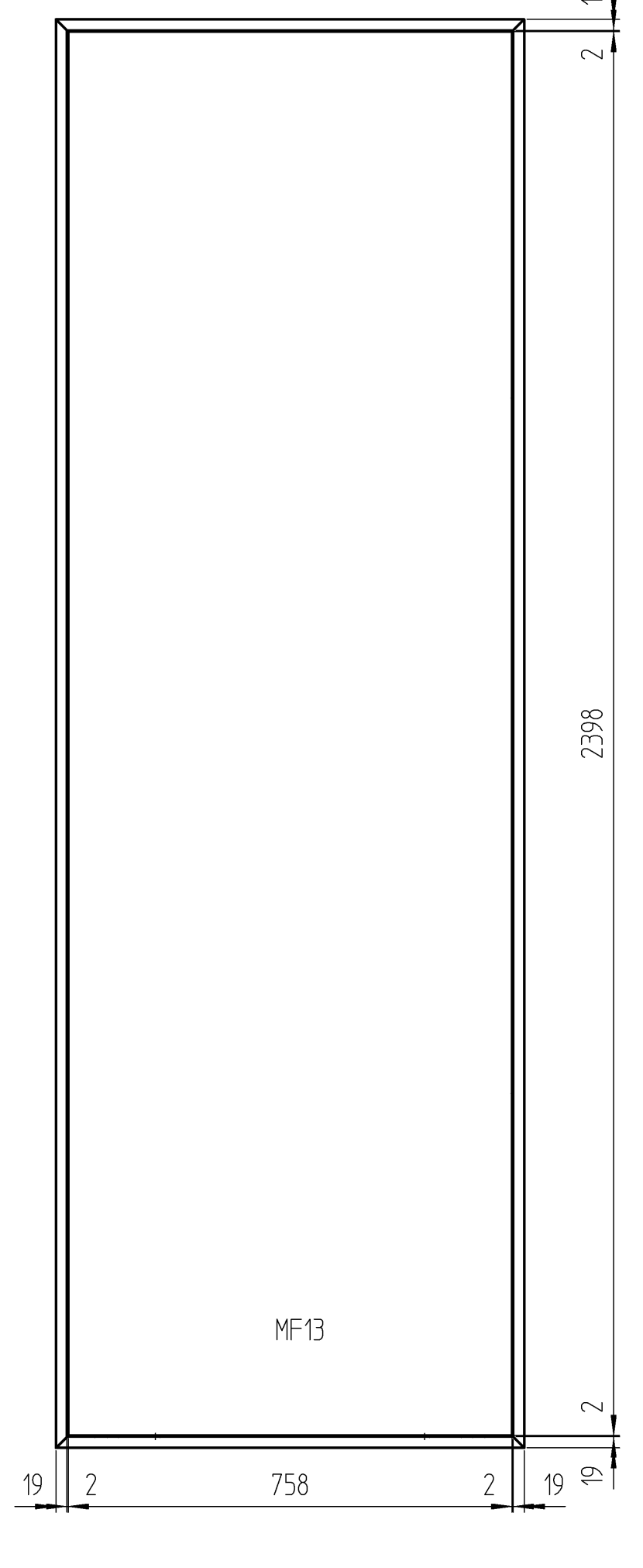
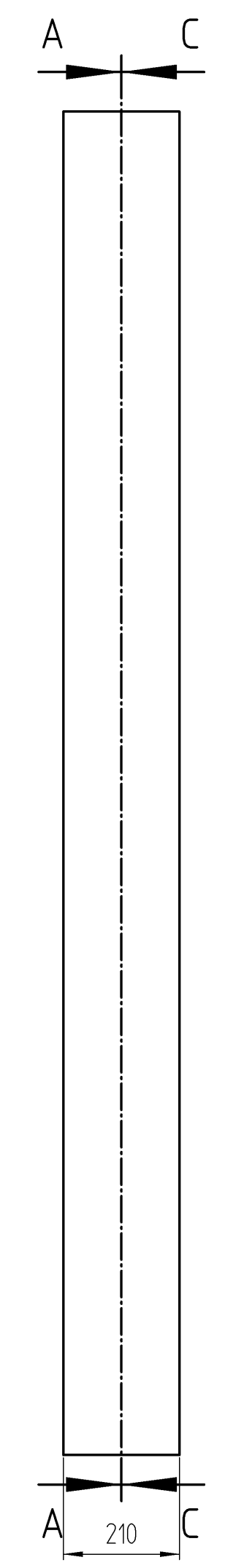
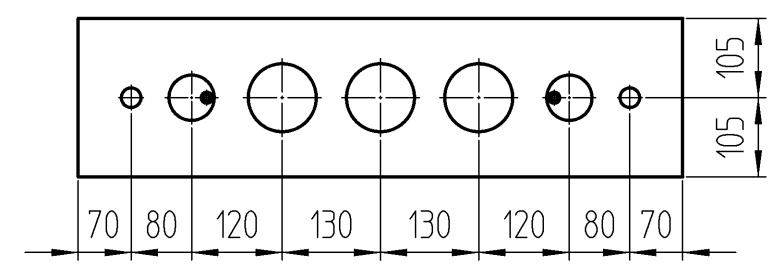
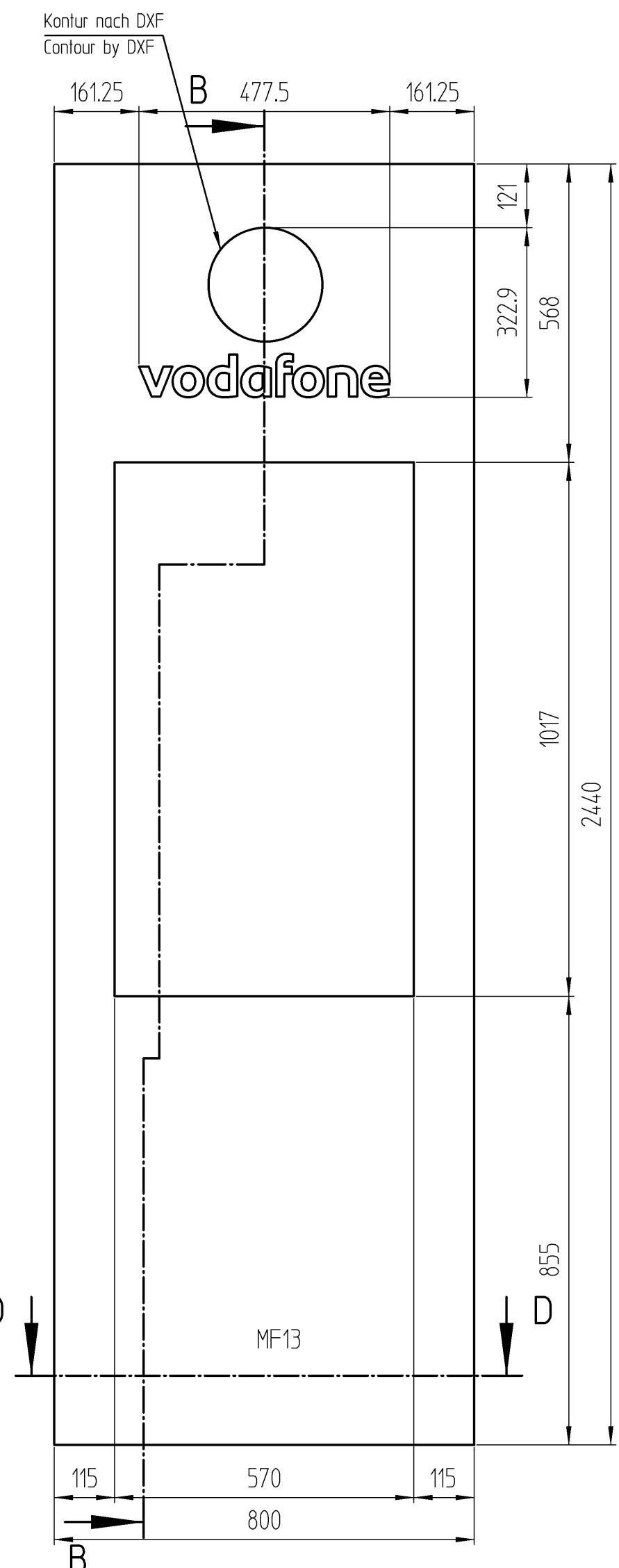
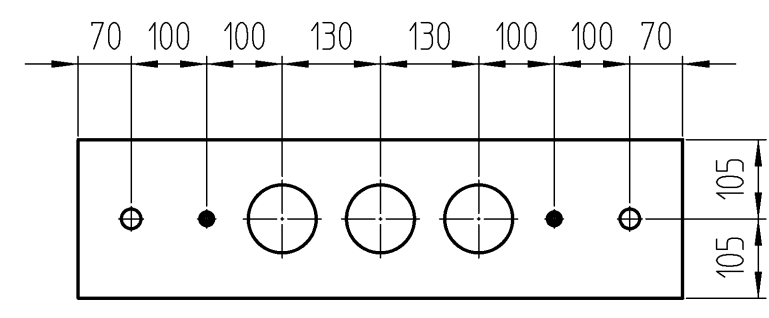

Holz, Oberfläche und Kanten nach Auftrag.  
Wood, surface and edges to be advised.

Piece	Designation/Description	Drawing/Mat.-Nr.	Pos	Material	DIN/VBN	Remark
5	door hinge 107° inset mounting	61279310	7			Häfele 342.80.504
2	counterplate 12x25	61279083	6			Häfele 246.26.793
2	magnetic pressure catch	61279081	5			Häfele 245.67.310
2	adjustable foot D25x6 M8x30	61255122	4			Bethke 70-25 M8x30
2	hreaded insert M8x18 Typ SKD	61121321	3			Rampa 440 818 001
8	hreaded insert M6x15 Typ SKD	61121161	2	St		Rampa 440 615 001
2	hreaded insert M10x20 Typ SKD	61121058	1	St		Rampa 440 120 001



Version 2.0  
DRAWING REFERENCE IMAGE:

NOTES:  
C: cut out in side removed & inserts added  
30.07.13 Keppler  
D: logo recess 14mm was 10mm  
30.08.13 Keppler

KEY TO ABBREVIATIONS:  
CL - Centre Line  
FFL - Finished Floor Level  
R - Radius  
→ - Direction of Wood Grain

MATERIALS FOR ALL MATERIAL FINISHES (MF reference) REFER TO THE SEPERATE MATERIAL FINISHES SCHEDULE - DRAWING NUMBER - SH00.

DRAWING TITLE:  
Carcass

SCALE: 1:10  
SHEET SIZE: To Scale @ A1  
DRAWN BY: Keppler  
DATE: 19.07.13  
SERIES NO: 2.0  
DWG NO:  
DIN/VBN  
REVISION:

174-038 D

IN WORK