

VENT-AXIA TURBOPROP - HIGH PRESSURE AXIAL FANS (TP)

Vent-Axia

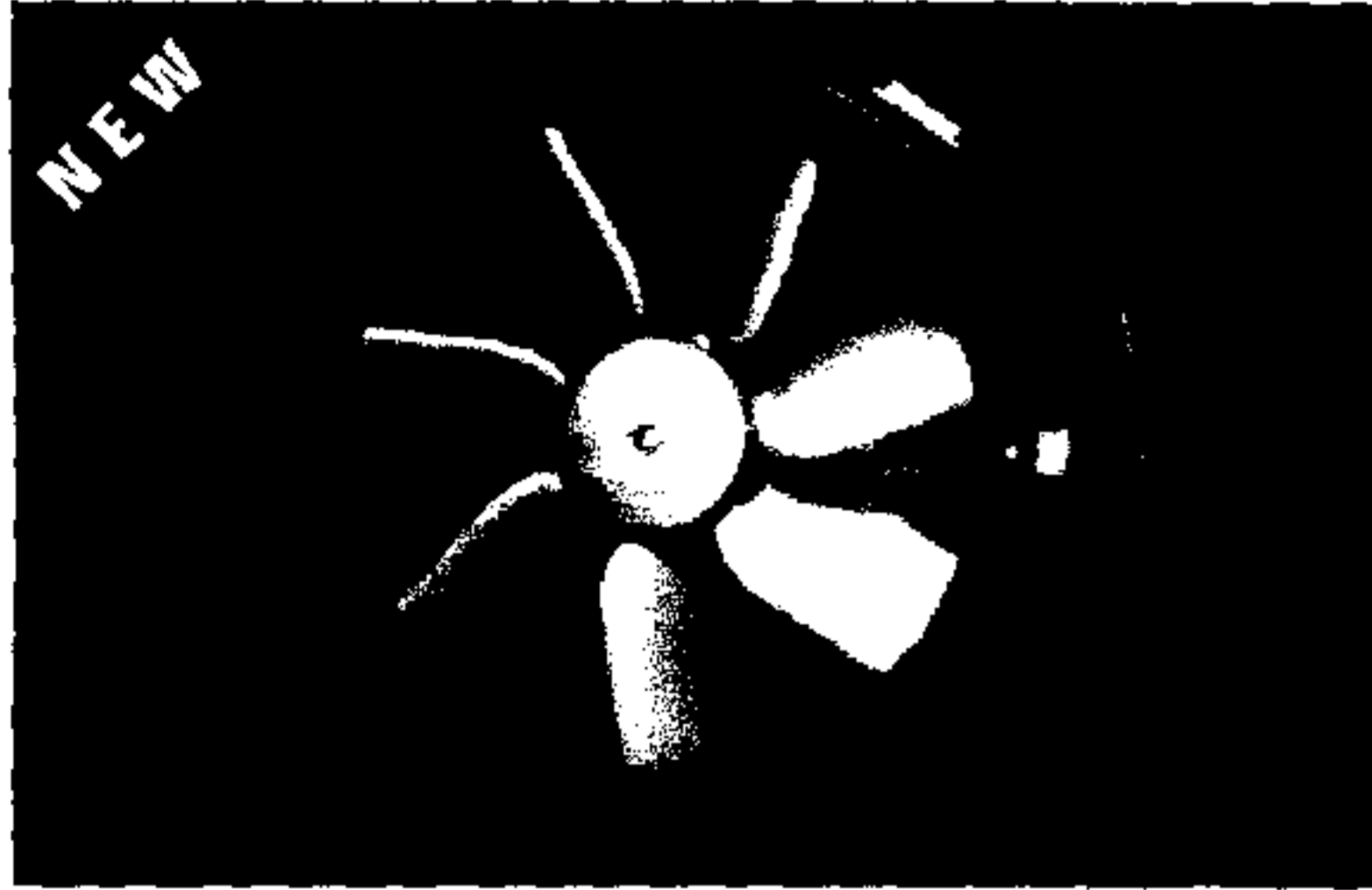

- ✓ Contra Rotating, die cast aluminium impellers.
- ✓ Compact in size, equivalent to standard long case axial fans.
- ✓ Available from 450 to 630 diameter, 1 or 3 phase.
- ✓ Speed controllable.
- ✓ All units fully protected to IP65, ideally suited for internal or external installations.
- ✓ Motor insulation Class F, suitable for operating temperatures from -40°C to +70°C.
- ✓ Motors protected with Standard Thermal Overload Protection.
- ✓ Manufacture controlled to BS EN ISO 9001.
- ✓ Performance tested to BS 848 Parts 1 & 2.

TURBOPROP

More efficient kitchen filtration systems and ever larger duct runs have created a need for a new generation of competitively priced high pressure axial fans, suitable for higher working temperatures.

The range offers a new alternative to the H & V industry.

The all-new Vent-Axia TurboProp is a revolutionary design contra rotating case axial. Equivalent in length and up to 2 times the pressure characteristics of traditional long case axial fans.

Available in four sizes: 450, 500, 560 and 630mm diameter with a performance from 0.688m³/s to 4.346m³/s (2,476m³/h to 15,645m³/h) and pressure development up to 800Pa.

Ensuring a compact design, the units have been constructed from a single sheet of steel, with both motors and axial impellers mounted within the length of the unit casing. The motor mounting supports are manufactured from steel rod, electro welded and epoxy paint finished, factory assembled to BS EN ISO 9001 ensuring a quiet and vibration free unit.

All sizes are protected with a tough black epoxy paint finish for those harsh environmental conditions, internally or externally. Ensuring ease of installation both motors are wired directly into a single IP65 terminal box.

IMPELLERS

The contra rotating impellers are manufactured in die-cast aluminium and are fitted with narrow profiled blades, which provide the maximum efficiency at the maximum airflow.

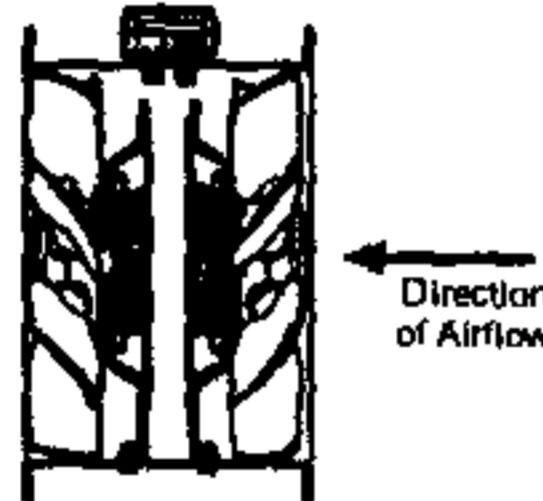

AXIAL MOTORS

Specifically designed and styled for this range of fans. Ball bearings are greased for life and allow the fans to be installed at any angle. Rotors are dynamically balanced to ISO 1940. Motors are protected to IP65 against dust and water jets complying with BS EN 60529. They have ribbed aluminium body castings for efficient cooling. Motor insulation is Class 'F' (from -40°C to +70°C).

Sizes 450 and 500 are suitable for speed control by either electronic or voltage reduction controllers. All 3-Phase models are suitable for speed control by frequency inverter.

ELECTRICAL

Single phase 220-240V/50 Hz. Capacitor start and run. Three phase 380V-415V/50Hz. All motors are fitted

with Standard Thermal Overload Protection (S.T.O.P), which should be wired into all controller circuits and into starter contactors

TERMINAL BOX

IP65 terminal box is supplied with all models with 20mm and PG11 entry.

PERFORMANCE

The fan performance is in accordance with tests to BS 848 Part 1 1980.

SOUND LEVELS

Fan sound levels, measured in a reverberant chamber in accordance with BS 848 Part 2. Published dB(A) figures are free field sound pressure levels at 3m with spherical propagation at a reference level of 2 x 10⁻⁵Pa (20 micro-Pascal). The sound power level spectra figures are dB with a reference level of 10⁻¹² Watts (1 pica-watt). To ensure minimum noise levels during speed control, an auto transformer speed control is recommended.

ACCESSORIES

- Electronic Speed Controllers
- Auto Transformer Speed Controllers
- Inverter Speed Controllers
- Ancillary Packs
- Case Attenuators
- Mounting Feet
- Wire Inlet Guard
- Coupling Flanges

TURBOPROP FANS PERFORMANCE GUIDE

1 PHASE, 4 POLE

Unit Code	Nom. RPM	Phase	m ³ /s at Pa										Motor kW	SC Amps	FL Amps	
			0	50	100	150	200	300	400	500	600	700				800
TP450-14	1370	1	1.858	1.800	1.741	1.673	1.605	1.431	1.197					1.24	21.60	5.10
TP500-14	1300	1	2.472	2.413	2.336	2.249	2.140	1.856	1.474					1.70	28.00	6.50
TP560-14	1340	1	3.852	3.785	3.668	3.571	3.454	3.193	2.662					3.25	56.00	17.50
TP630-14	1280	1	4.748	4.629	4.498	4.356	4.192	3.799	3.297	2.664	1.712			3.90	78.00	23.00

3 PHASE, 4 POLE

Unit Code	Nom. RPM	Phase	m ³ /s at Pa										Motor kW	SC Amps	FL Amps	
			0	50	100	150	200	300	400	500	600	700				800
TP450-34	1400	3	1.841	1.794	1.739	1.688	1.628	1.475	1.202					1.25	20.40	5.40
TP500-34	1340	3	2.500	2.460	2.387	2.314	2.235	2.046	1.809					1.75	21.60	6.60
TP560-34	1360	3	3.808	3.735	3.638	3.541	3.444	3.202	2.643	2.668				3.12	34.40	5.80
TP630-34	1370	3	4.897	4.800	4.702	4.580	4.483	4.239	3.971	3.679	3.333	2.339	1.666	4.20	48.00	8.00

S.C. = STARTING CURRENT
F.L.C. = FULL LOAD CURRENT

SOUND DATA

Sound Power Level Spectra dB (re 10⁻¹²Watts)

Unit Code		MID-OCTAVE BANDS								dB(A) @ 3m
		63	125	250	500	1k	2k	4k	8k	
TP450	Inlet	72	69	63	64	63	77	70	64	68
	Outlet	77	80	83	87	86	80	73	67	70
TP500	Inlet	78	92	93	88	88	79	72	67	71
	Outlet	88	91	95	90	88	82	75	71	72
TP560	Inlet	83	95	92	89	89	83	77	71	72
	Outlet	96	98	93	91	92	86	80	75	75
TP630	Inlet	81	101	94	91	91	85	79	71	74
	Outlet	97	102	95	94	94	88	82	77	77

Published dB(A) figures are free field sound levels at 3m with spherical propagation at a reference level of 2 x 10⁻⁵ Pa. The free field sound power level spectra figures are dB with reference of 10⁻¹² Watts. To ensure minimum noise levels during speed control an auto transformer or inverter speed controller is recommended.

Attenuator Insertion Losses

Dia	63	125	250	500	1k	2k	4k	8k
450	2	4	6	14	17	12	10	6
500	3	4	7	14	17	14	11	7
560	3	4	8	15	18	14	11	7
630	3	4	8	16	18	14	11	7

Attenuator Fitted with Pod Insertion Losses

Dia	63	125	250	500	1k	2k	4k	8k
450	4	8	14	20	28	26	22	19
500	4	8	14	20	29	26	22	19
560	4	9	14	20	29	26	22	19
630	4	9	14	20	29	26	22	19

DIMENSIONS (mm)

Size	Da	b	De	De	De	n	kg approx
450	450	375	500	537	12	8	36
500	500	375	580	595	12	12	38
560	560	520	620	655	12	12	56
630	630	520	690	725	12	12	83

VENT-AXIA TURBOPROP FANS ACCESSORIES



Stock Ref. No.	Electronic Controller Stock Ref. No.	Auto Transformer Stock Ref. No.	Inverter Kit 3ph in/out Stock Ref. No.	D.O.L. Starter Stock Ref. No.	Ancillary Pack Stock Ref. No.	Mounting Feet (pair) Stock Ref. No.	Coupling Flange Stock Ref. No.
TP450-14	103 03 110A	103 14 107	-	103 11 240 + 103 12 070	-	-	-
TP450-34	-	103 14 304	103 20 302 04	103 11 415 + 103 12 040	105 13 450	105 03 450	105 06 450
TP500-14	103 03 110A	103 14 113	-	103 11 240 + 103 12 105	-	-	-
TP500-34	-	103 14 304	103 20 303 01	103 11 415 + 103 12 040	105 13 500	105 03 500	105 06 500
TP560-14	-	-	-	103 11 240 + 103 12 039	-	-	-
TP560-34	-	-	103 20 305 04	103 11 415 + 103 12 070	105 13 560	105 03 560	105 06 560
TP630-14	-	-	-	103 11 240 + 103 12 039	-	-	-
TP630-34	-	-	103 20 350 02	103 11 415 + 103 12 105	105 13 630	105 03 630	105 06 630

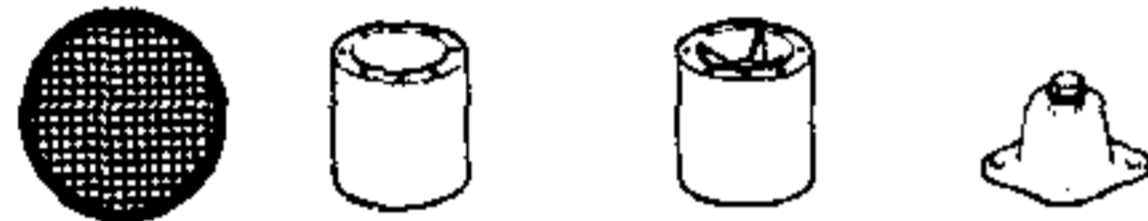

Stock Ref. No.	Inlet Wire Guard Stock Ref. No.	Case Axial Attenuator Stock Ref. No.	Case Axial Attenuator Incl. Pod Stock Ref. No.	Anti-Vibration Mounts Stock Ref. No.
TP450-14	105 05 450	105 14 450	105 00 450	105 23 033
TP500-14	105 05 500	105 14 500	105 00 500	105 23 033
TP560-14	105 05 560	105 14 560	105 00 560	105 23 033
TP630-14	105 05 630	105 14 630	105 00 630	105 23 033

* Ancillary Packs consist of:
4 Anti-Vibration Mounts
2 Matching Flanges
2 Mounting Feet
2 Flexible Connections

Guards: Some installations may occur where additional safety parts are needed, to ensure safety in operation. For example, the unit may be fitted at the inlet or outlet end of a ducted ventilation system, thereby exposing the Impeller/motor to unguarded access. In this event, the installer must fit a safety guard complying to current regulations. These guards are available as an optional extra.

ACCESSORIES DIMENSIONS (mm)

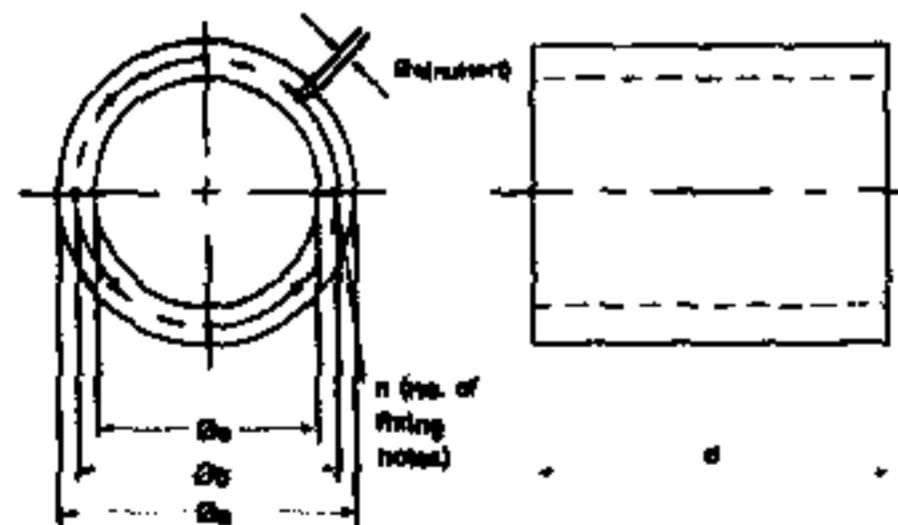

CASE AXIAL ATTENUATOR

Stock Ref. No.	Øa	bØ	Øc	d	Øe*	n	kg approx	Fitted with pod kg approx	Free area m ² without pod
105 14 450	550	500	450	675	M10	8	50	73	0.15904
105 14 500	600	560	500	750	M10	12	59	87	0.19635
105 14 560	660	620	560	840	M10	12	70	102	0.24630
105 14 630	730	680	630	940	M10	12	82	120	0.31172

* Threaded hole to take bolt

RESISTANCE GRAPH FOR CASE ATTENUATOR FITTED WITH POD

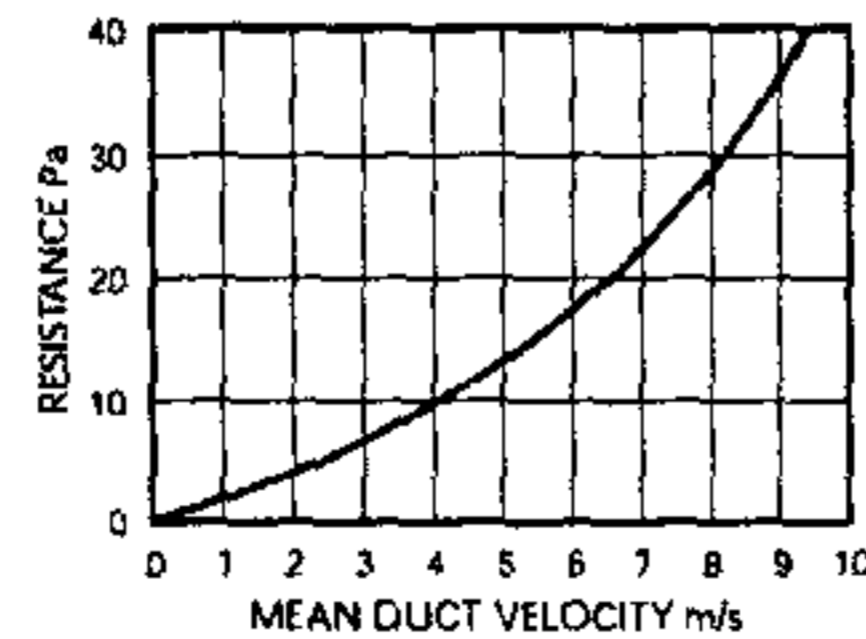

TURBOPROP FANS ACCESSORIES DIMENSIONS (mm)

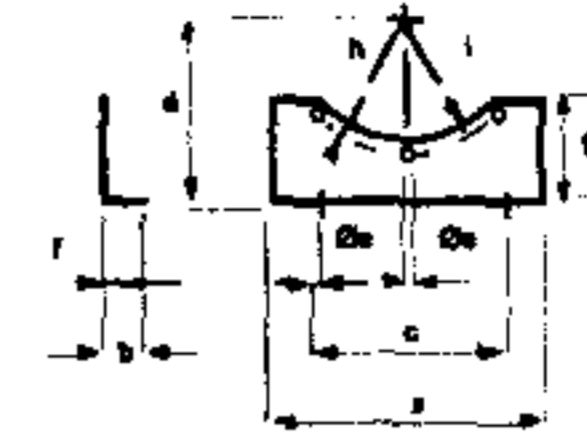

MOUNTING FEET

Stock Ref. No.	a	b	c	d	Øa	f	g	h	i
105 03 450	384	24	315	315	12	14	155	250	238
105 03 500	425	24	315	315	12	14	135	280	268
105 03 560	475	24	355	355	12	14	155	310	298
105 03 630	520	24	400	400	12	14	175	345	333

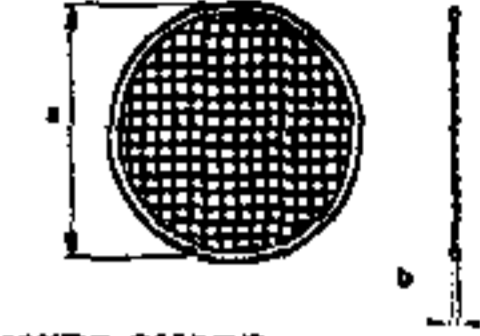

INLET WIRE GUARD 'K' factor loss 0.25

Stock Ref. No.	Øa	b
105 05 450	525	3
105 05 500	595	3
105 05 560	655	3
105 05 630	725	3

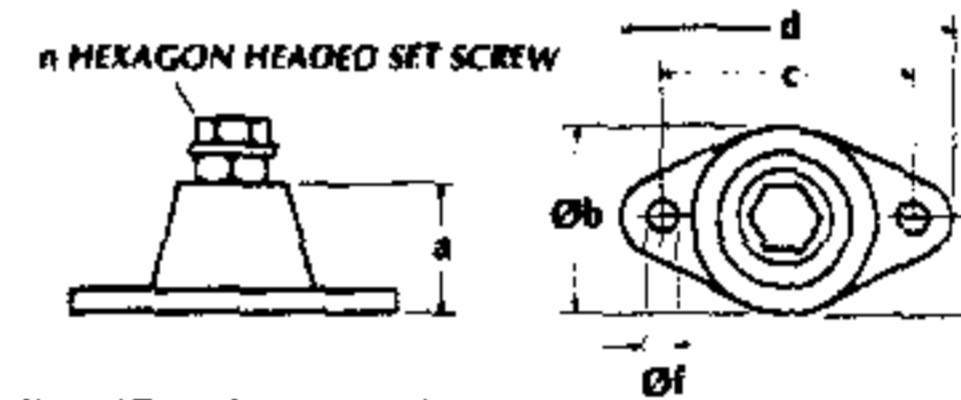

ANTI-VIBRATION MOUNTS

Stock Ref. No.	a	Øb	c	d	e	Øf	n	Max load kg
105 23 033	27	37	54	67	18.5	7	M8	23

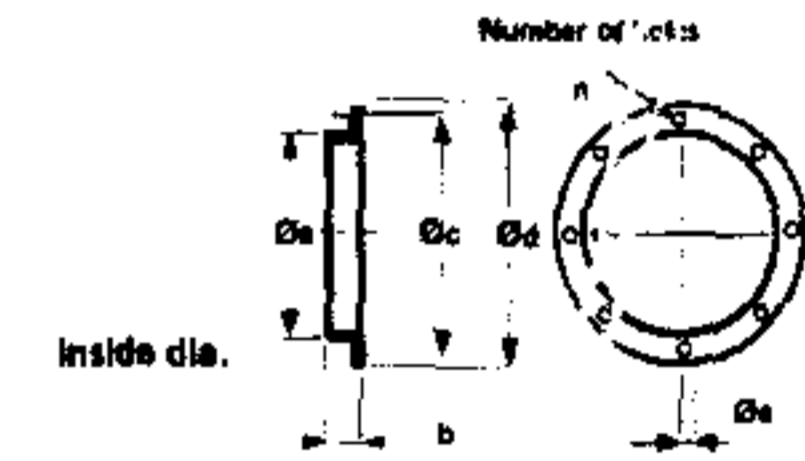

COUPLING FLANGE

Stock Ref. No.	Øa	b	Øc	Ød	f	n
105 06 450	450	60	500	537	8	8
105 06 500	500	60	560	595	2	8
105 06 560	560	75	620	655	12	12
105 06 630	630	75	690	725	12	12

PERFORMANCE

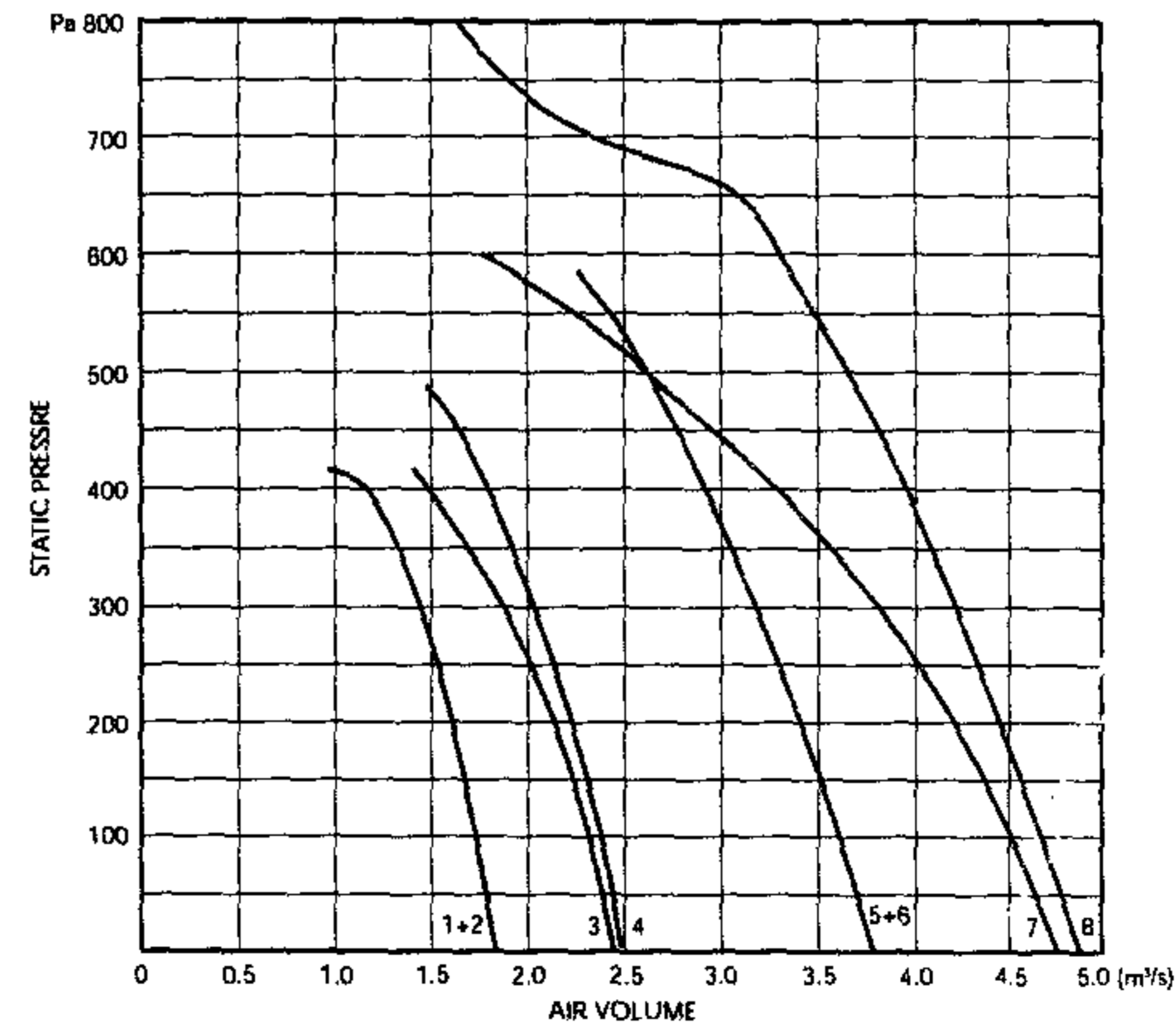

See	TP450/1&3	TP500/1	TP560/3	TP630/1&3	TP630/1	TP630/3
	1+2	3	4	5+6	7	8

ICS 5000

Multifunctional

Insulated Venting System

Atmospheric gas/oil appliances.

Diesel/petrol powered generators.

Pressure jet oil or forced draught gas appliances.

Ancillary service trunking.

Boiler and waste gas extraction.

Industrial process fume extraction.



ICS 5000

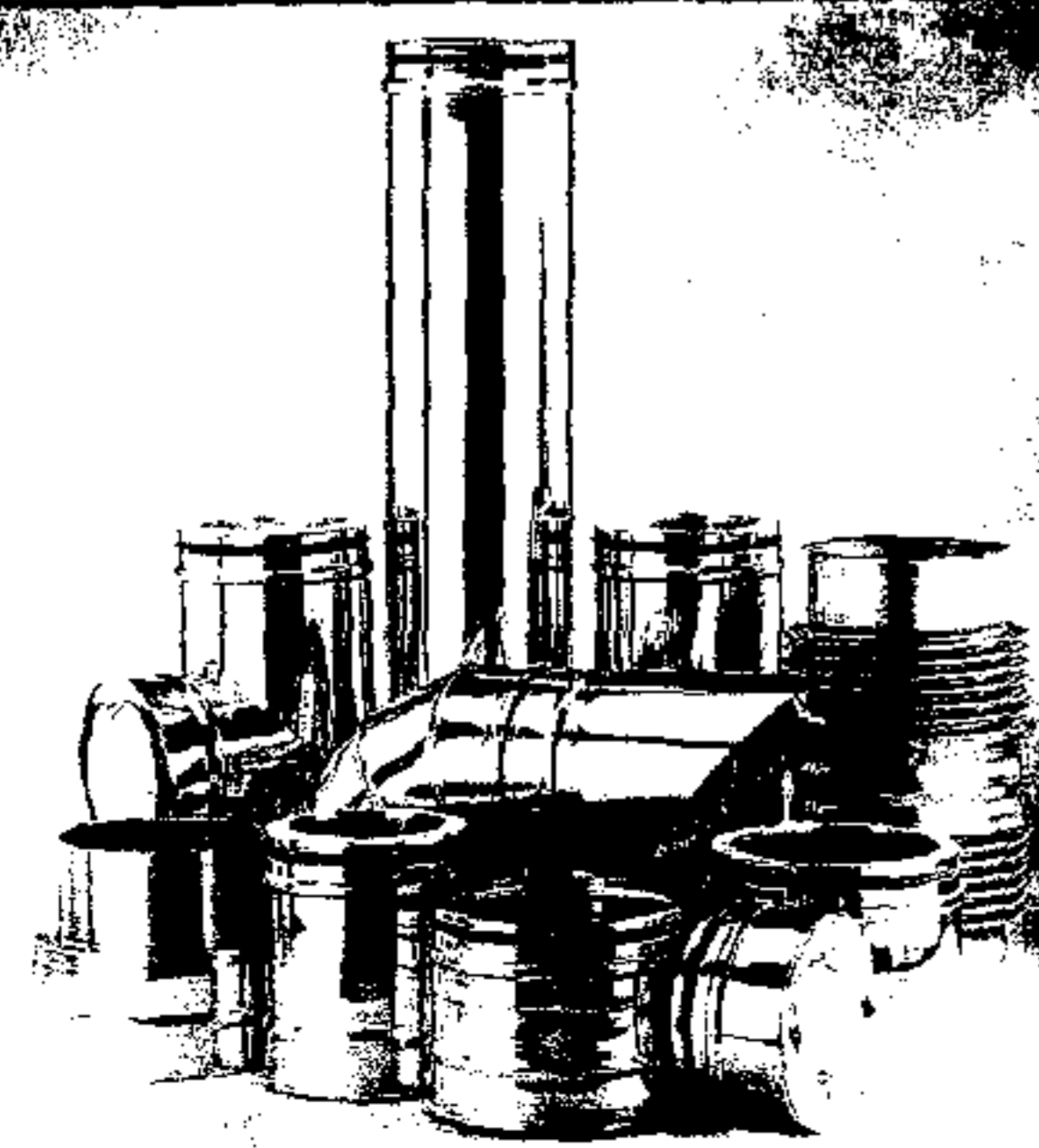

RITE-VENT

RITE-VENT



ICS 5000

ICS 5000 is a multifunctional twin wall insulated venting system designed for use on a wide range of heating, process, ventilation and service ducting applications. It is available in 12 diameters from 150mm - 605mm. The system provides optimum performance criteria for high temperature applications where positive, zero or negative pressure conditions prevail at the appliance or equipment outlets. The ICS 5000 system comprises of pipe sections, bends, tees and other insulated flue gas carrying components which are designed to provide individual independent expansion within the jointing system. Additionally there is a comprehensive range of support components and fittings, together with various pressure components which complement the product.



ICS 5000

ICS 5000 has a high quality specification as standard, incorporating a stainless steel 316L liner, 25mm insulated cavity and a bright annealed stainless steel 304 outer case. Both liner and outer case have a continuous laser or inert gas welded seam throughout and each flue gas carrying component has a unique profiled spigot and socket joint with bevelled end form. The thermal insulated blanket which encases the entire effective length of the liner, ensures fast priming to normal operating temperature, providing efficient venting of the flue gases whilst maintaining a low external surface temperature. These design features combine to achieve the following:-

- Smoothness and free movement of the liner.
- Superior mechanical strength of the outer case.
- A lead in edge at the joint.
- An internal and external water barrier.

The design and construction of ICS 5000 provides a lightweight, economical and easily installed alternative to conventional heavy gauge welded steel systems with the following benefits:-

- Quick and easy assembly.
- Excellent load bearing capability.
- Freedom of the liner to expand and contract.
- Proven corrosion resistance.
- Pressure and water tightness characteristics.
- Tested by TUV.

The system is also available with a 50mm insulated cavity and other material specifications depending on the application.

ICS 5000

ICS 5000 as with all Rite-Vent product is manufactured under the stringent requirements of BS EN ISO 9002 Quality Management Scheme. Rite-Vent is a BSI registered firm, certificate No. FM25918.



ICS 5000

ICS 5000 is suitable for internal and external use on a wide range of engineering, combustion and process equipment.

Applications include the following:-

- Atmospheric gas/oil appliances.
- Diesel/petrol powered generators.
- Pressure jet oil or forced draught gas appliances.
- Ancillary service trunking.
- Boiler and waste gas extraction.
- Industrial process fume extraction.

ICS 5000 provides for continuous operating temperatures of 550°C with short firing up to 750°C where positive, zero or negative pressure conditions prevail. The 50mm cavity option is suitable for high temperature applications up to 750°C continuous firing temperatures and short firing temperatures up to 1100°C. For more detailed information please refer to the technical data on page 2 of this brochure.

ICS 5000

ICS 5000 is engineered to withstand considerable positive and negative pressures in a variety of applications. The system has been satisfactorily tested in accordance with DIN 24194-1 and DIN V24194-2, these being regarded as the most appropriate European Standard to which reference can be made. ICS 5000 when installed in accordance with our detailed installation instructions, will conform to the above standards and pressure tightness requirements at 5000 Pa. For those applications which may require pressure capabilities above 5000 Pa, details are available from Rite-Vent Technical Department.

ICS 5000 has been independently tested and has achieved a 4 hr. fire rating in accordance with the stability and integrity criteria of BS476 part 20. This enables the system to be suitable for use as an insulated duct on ancillary applications such as communication and cable carrying systems, where fire protection of the equipment is essential. Full details of such fire rated applications are available separately upon request.

ICS 5000

In addition to the above relevant standards ICS 5000 system incorporates a comprehensive range of components from the ICS range, which are manufactured and approved to the following standards:-



Flanged Adaptor to ICS 5000

Int. Ø (mm)	150	180	200	230	250	300	355	405	455	505	555	605
Ext. Ø (mm)	200	230	250	280	300	355	405	455	505	555	605	655

This component is used to connect to boilers, flanged pipes, bellows and special size flanges which are available on request.

ICS 5000 to Flanged Adaptor

Int. Ø (mm)	150	180	200	230	250	300	355	405	455	505	555	605
Ext. Ø (mm)	200	230	250	280	300	355	405	455	505	555	605	655

This component is used to connect from ICS 5000 to a flanged pipe or bellows.

Three standard lengths of flanged pipe are available:-

Int. Ø (mm)	150	180	200	230	250	300	355	405	455	505	555	605
Ext. Ø (mm)	200	230	250	280	300	355	405	455	505	555	605	655

Effective Length	Part Ref.
988mm	
488mm	
238mm	

EFFECTIVE LENGTH

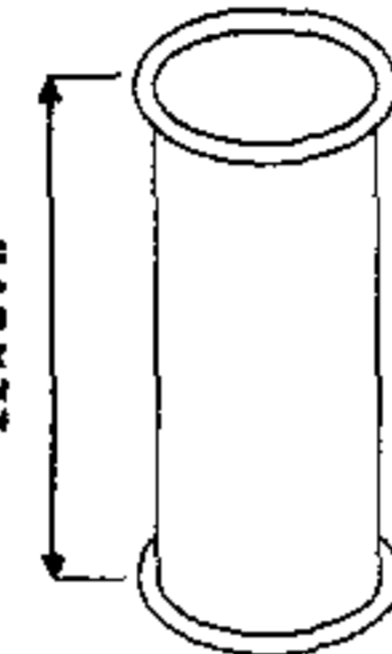

V Band

Int. Ø (mm)	150	180	200	230	250	300	355	405	455	505	555	605
Ext. Ø (mm)	200	230	250	280	300	355	405	455	505	555	605	655

A V band is supplied with all flanged pipes.

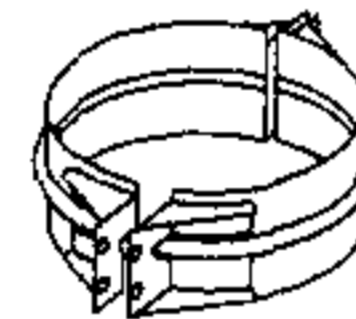

High Temp Sealant

This component MUST be used in conjunction with the flanged pipe and V band. This sealant MUST be used at every flanged joint and secured with a V band provided.



Bellows

These components are used to absorb expansion within the system.

Single Bellows

Int. Ø (mm)	405	455	505	555	605
Ext. Ø (mm)	455	505	555	605	655

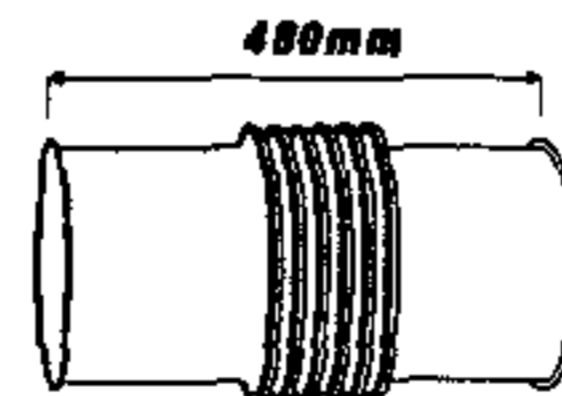

Double Bellows

Int. Ø (mm)	150	180	200	230	250	300	355	405	455	505	555	605
Ext. Ø (mm)	200	230	250	280	300	355	405	455	505	555	605	655

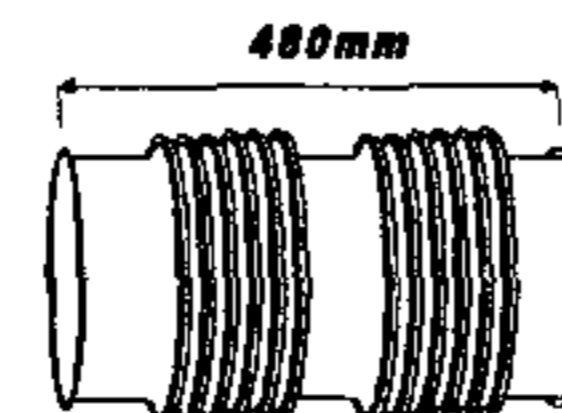

LOAD BEARING DATA (METRES OF PIPE)

		25MM CAVITY											
TABLE 1	Floor Support	18	18	18	18	18	18	6	6	6	6	6	4
	Wall Support (A)	15	15	15	15	15	15	12	12	12	12	12	10
	Wall Support (B)	10	10	10	10	10	10	10	10	10	8	8	6
	90° Tee	18	18	18	18	18	18	6	6	6	6	6	4
	Adj. Ceiling Support	15	15	15	15	15	15	10	10	10	6	6	4

WALL SUPPORTS

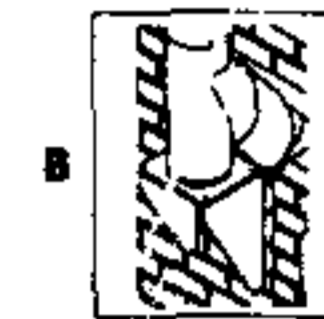
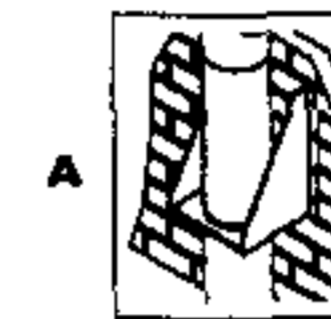

		50MM CAVITY											
TABLE 2	Floor Support	10	10	10	10	10	10	6	6	6	4	4	2
	Wall Support (A)	15	15	15	15	15	15	10	10	10	10	10	10
	Wall Support (B)	10	10	10	10	10	10	6	6	6	6	6	6
	90° Tee	10	10	10	10	10	10	6	6	6	4	4	2
	Adj. Ceiling Support	15	15	15	15	15	15	6	6	6	6	6	6

APPROXIMATE WEIGHTS OF FINISHED GOODS (Kg)

		25MM CAVITY											
TABLE 3	1000mm Pipe	6.41	7.48	8.19	9.26	9.96	13.73	15.59	17.64	19.98	21.71	25.32	27.50
	500mm Pipe	3.15	3.68	4.03	4.54	4.89	6.75	7.70	8.70	9.70	10.70	12.50	13.58
	250mm Pipe	1.61	1.88	2.05	2.32	2.49	3.44	3.93	4.45	4.97	5.47	6.38	6.93
	90° Tee	3.72	4.31	4.70	6.00	6.64	8.56	11.56	13.87	16.36	23.65	28.65	32.63

		50MM CAVITY											
TABLE 4	1000mm Pipe	9.38	10.73	11.66	13.02	14.34	18.25	20.59	23.11	25.64	29.75	32.41	35.07
	500mm Pipe	4.67	5.35	5.80	6.47	7.12	9.08	10.25	11.51	12.73	14.82	16.13	17.46
	250mm Pipe	2.05	2.35	2.54	2.84	3.11	4.03	4.57	5.13	5.68	6.65	7.24	7.83
	90° Tee	5.18	6.12	6.71	7.38	9.56	13.26	15.99	19.05	22.36	32.74	37.54	42.66

A purpose made flange, to special order, can be provided attached to component ref. J2445 (page 3). This component is used to connect to the ready flanged outlet of the appliance and is securely bolted and sealed, using fixings supplied by others.

PLEASE PHOTOCOPY THIS PAGE AND COMPLETE AS FOLLOWS:-

Insert all relevant information in the eight boxes below. The completed schedule should be posted or faxed (0191 415 1263) to Rite-Vent for the attention of the sales office.

Thickness of Flange mm

Material

No. X mmØ

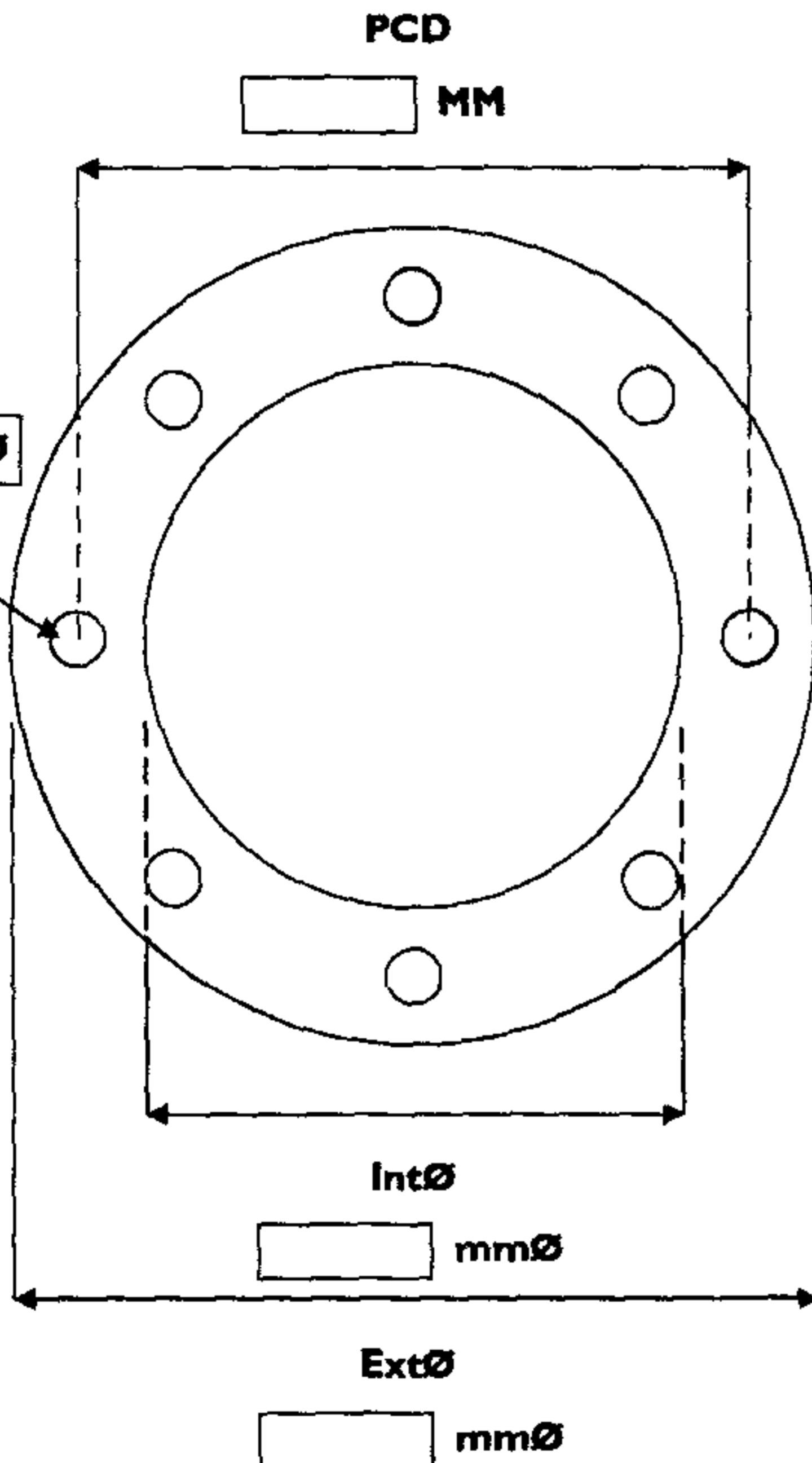

PLEASE COMPLETE IN BLOCK CAPITALS

NAME: _____

COMPANY: _____

TEL. NO: _____

FAX NO: _____

DATE: _____

SIGNED: _____

Appliance Connector

Int Ø(mm)	150	180	200	230	250	300	355	405	455	505	555	605
Ext Ø(mm)	200	230	250	280	300	355	405	455	505	555	605	655

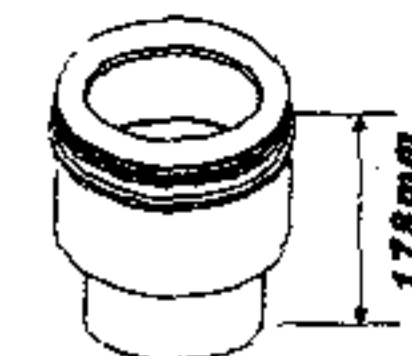

Increaser

Int Ø(mm)	150	180	200	230	250	300	355	405	455	505	555	605
Ext Ø(mm)	200	230	250	280	300	355	405	455	505	555	605	655
'A'	180	200	230	250	300	355	405	455	505	555	605	
'B'	230	250	280	300	355	405	455	505	555	605	655	

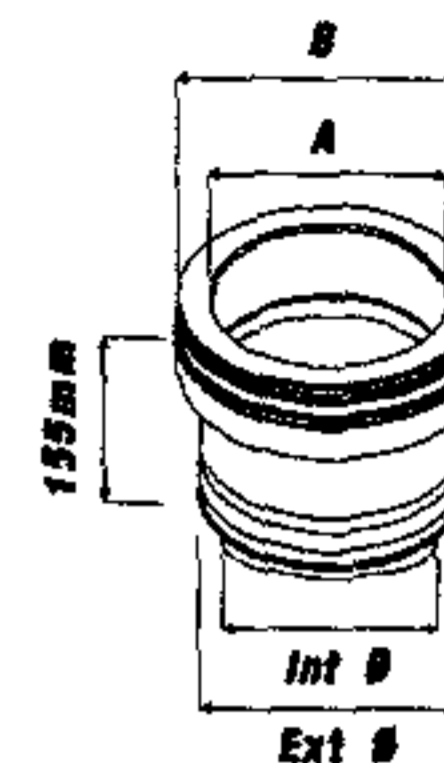

Four standard lengths of pipe are available:-

Int Ø(mm)	150	180	200	230	250	300	355	405	455	505	555	605
Ext Ø(mm)	200	230	250	280	300	355	405	455	505	555	605	655

Nominal Length	Effective Length	Part Ref.
1000mm	955mm	
500mm	455mm	
250mm	205mm	
195mm	150mm	

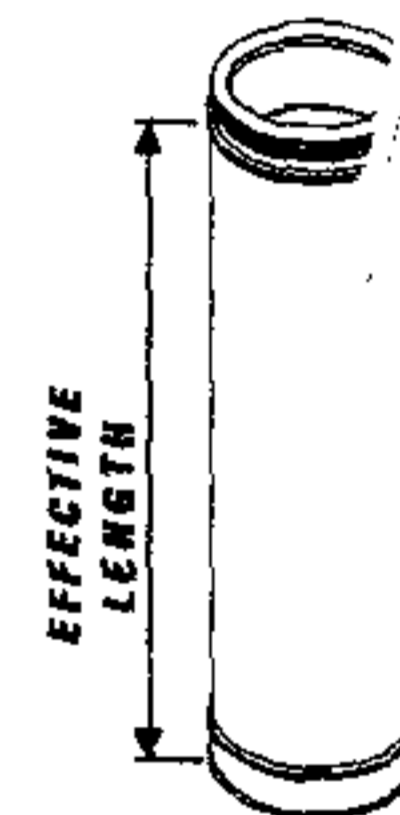

Locking Band

Int Ø(mm)	150	180	200	230	250	300	355	405	455	505	555	605
Ext Ø(mm)	200	230	250	280	300	355	405	455	505	555	605	655

A locking band is supplied with all components which have a female socket, but is also available separately, as shown.



Adjustable Pipe (270mm - 375mm)

Int Ø(mm)	150	180	200	230	250	300	355	405	455	505	555	605
Ext Ø(mm)	200	230	250	280	300	355	405	455	505	555	605	655

This component has pressure tight capabilities but is NOT load bearing. The adjustable pipe should be used in conjunction with a suitable support component when used in the vertical position.

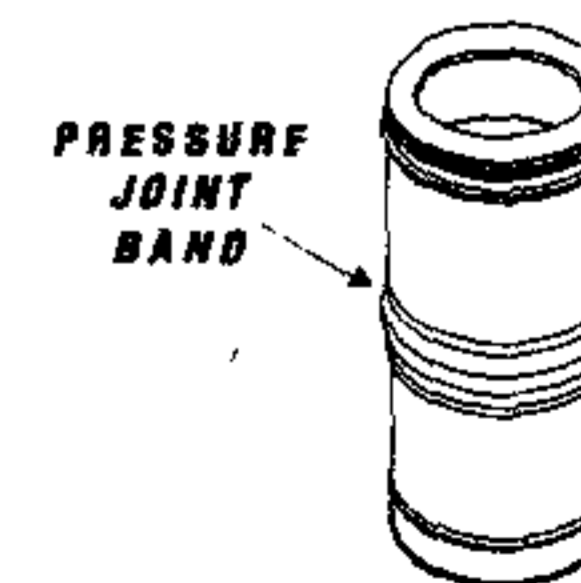

15° Bend

Int Ø(mm)	150	180	200	230	250	300	355	405	455	505	555	605
Ext Ø(mm)	200	230	250	280	300	355	405	455	505	555	605	655
'A'	93	95	96	98	100	103	107	110	113	137	140	143
'B'	48	50	51	53	55	58	62	65	68	97	100	103
'R'	344	351	355	363	370	382	397	408	420	519	531	544

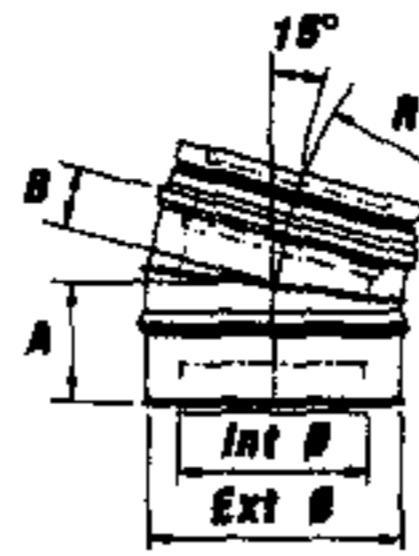

30° Bend

Int Ø(mm)	150	180	200	230	250	300	355	405	455	505	555	605
Ext Ø(mm)	200	230	250	280	300	355	405	455	505	555	605	655
'A'	107	111	113	118	120	128	134	141	148	192	198	206
'B'	62	66	68	73	75	83	89	96	103	152	158	166
'R'	195	203	207	216	220	235	246	259	272	410	426	460

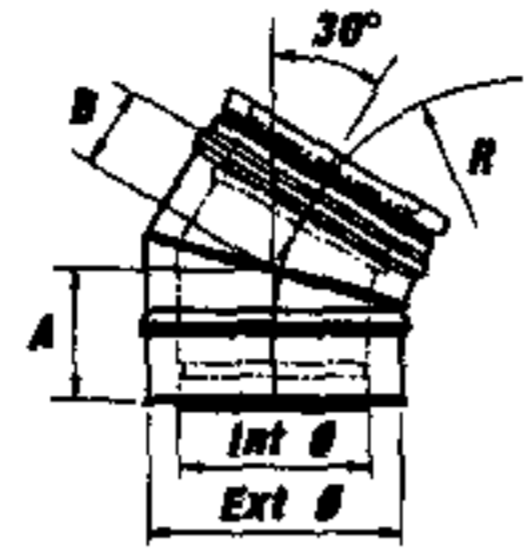

45° Bend

Int Ø(mm)	150	180	200	230	250	300	355	405	455	505	555	605
Ext Ø(mm)	200	230	250	280	300	355	405	455	505	555	605	655
'A'	121	128	132	138	142	154	164	174	185	253	260	273
'B'	77	84	88	94	98	110	120	130	141	213	220	233
'R'	144	152	157	164	169	183	195	208	221	410	426	460

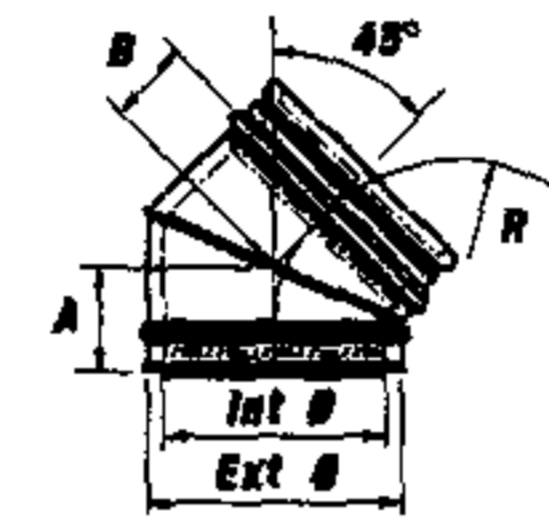

90° Bend

Int Ø(mm)	150	180	200	230	250	300	355	405	455	505	555	605
Ext Ø(mm)	200	230	250	280	300	355	405	455	505	555	605	655
'A'	194	209	219	234	244	272	164	174	185	253	260	273
'B'	149	164	174	189	199	227	120	130	141	213	220	233
'R'	124	139	150	164	174	202	195	208	221	410	426	460

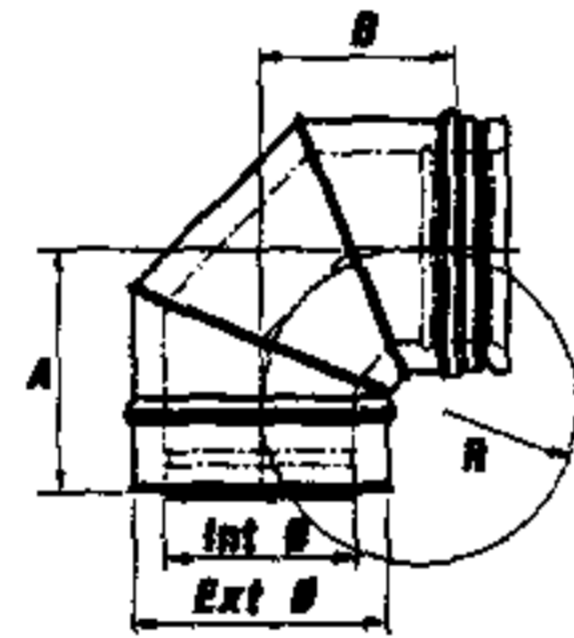

15° Offset

Int Ø(mm)	150	180	200	230	250	300	355	405	455	505	555	605
Ext Ø(mm)	200	230	250	280	300	355	405	455	505	555	605	655
'A'	277	285	289	297	305	317	332	344	356	460	472	484
'B'	36	38	38	39	40	42	44	45	47	61	63	64

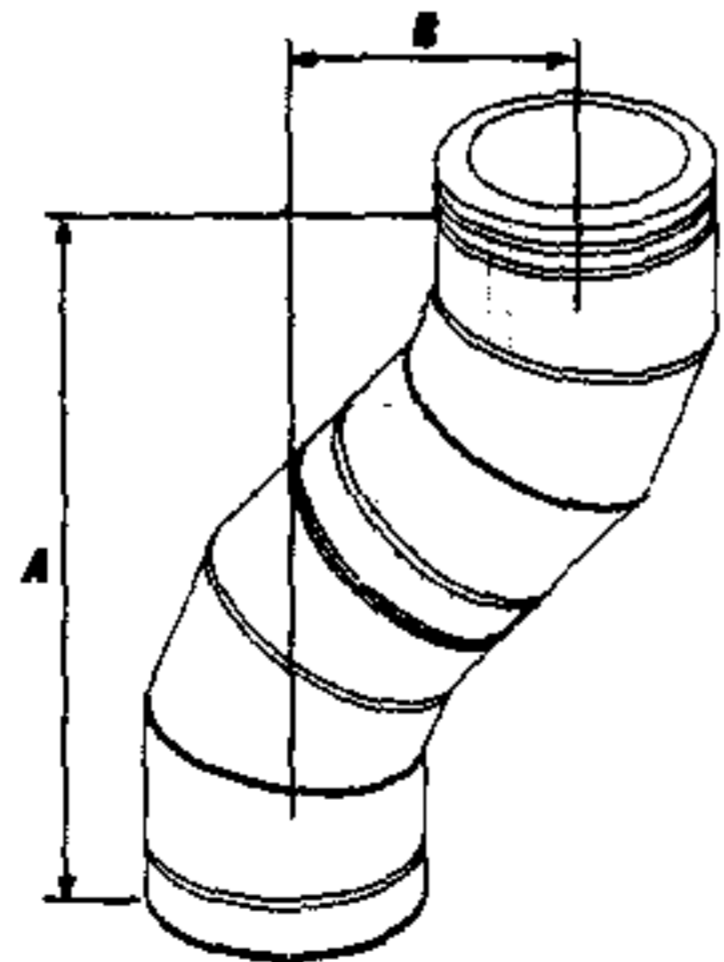

30° Offset

Int Ø(mm)	150	180	200	230	250	300	355	405	455	505	555	605
Ext Ø(mm)	200	230	250	280	300	355	405	455	505	555	605	655
'A'	315	330	338	356	364	394	416	442	468	642	664	694
'B'	85	89	91	96	98	106	112	119	126	172	178	186

45° Offset

Int Ø(mm)	150	180	200	230	250	300	355	405	455	505	555	605
Ext Ø(mm)	200	230	250	280	300	355	405	455	505	555	605	655
'A'	357	379	393	413	430	468	502	538	563	796	820	864
'B'	148	157	163	171	178	194	208	223	233	330	339	358

Terminal Section

Int Ø(mm)	150	180	200	230	250	300	355	405	455	505	555	605
Ext Ø(mm)	200	230	250	280	300	355	405	455	505	555	605	655

This component MUST be used in conjunction with a pressure system, and MUST be fitted directly below the terminal chosen for the application.

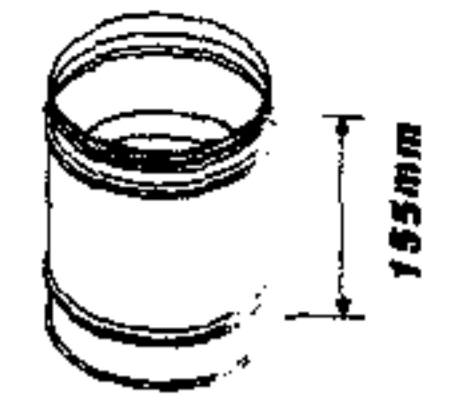

Universal Terminal

Int Ø(mm)	150	180	200	230	250	300	355	405	455	505	555	605
Ext Ø(mm)	200	230	250	280	300	355	405	455	505	555	605	655
'A'	300	330	350	430	450	555	605	735	785	915	965	1115
'B'	275	275	275	315	315	375	375	435	435	495	495	585
'C'	150	150	150	190	190	250	250	310	310	370	370	460

This terminal must NOT be used on a pressure application.

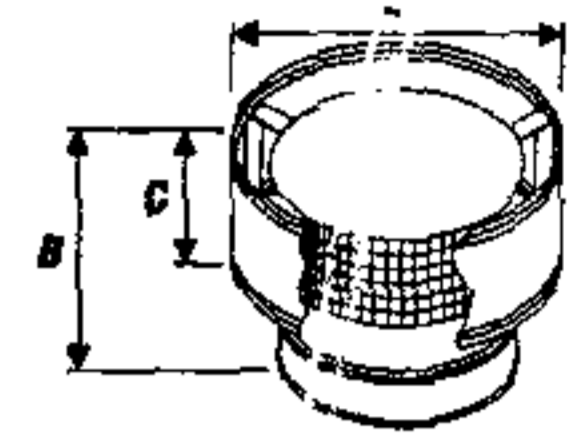

Raincap

Int Ø(mm)	150	180	200	230	250	300	355	405	455	505	555	605
Ext Ø(mm)	200	230	250	280	300	355	405	455	505	555	605	655
'A'	325	378	378	460	460	490	570	660	740	825	905	1000
'B'	235	250	260	280	290	355	400	440	475	515	555	595

This terminal must NOT be used on a pressure application.

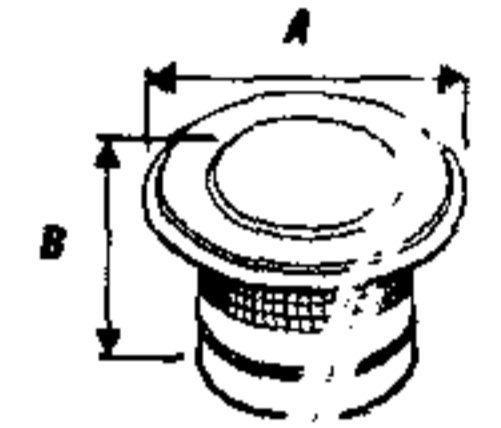

Tapered Terminal

Int Ø(mm)	150	180	200	230	250	300	355	405	455	505	555	605
Ext Ø(mm)	200	230	250	280	300	355	405	455	505	555	605	655

This terminal is suitable for all applications where a vertical termination is required, but will NOT prevent the ingress of water.

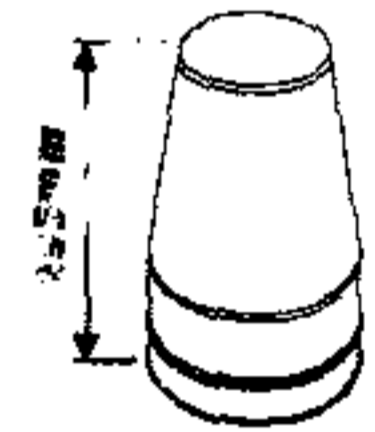

Exhaust Terminal (Vertical)

Int Ø(mm)	150	180	200	230	250	300	355	405	455	505	555	605
Ext Ø(mm)	200	230	250	280	300	355	405	455	505	555	605	655
'A'	270	285	295	310	320	393	418	443	468	493	510	543
'B'	355	600	630	675	705	833	908	983	1058	1133	1200	1283

This terminal is designed for all pressure applications where the termination discharges in a vertical run, and is fitted with a bird guard.

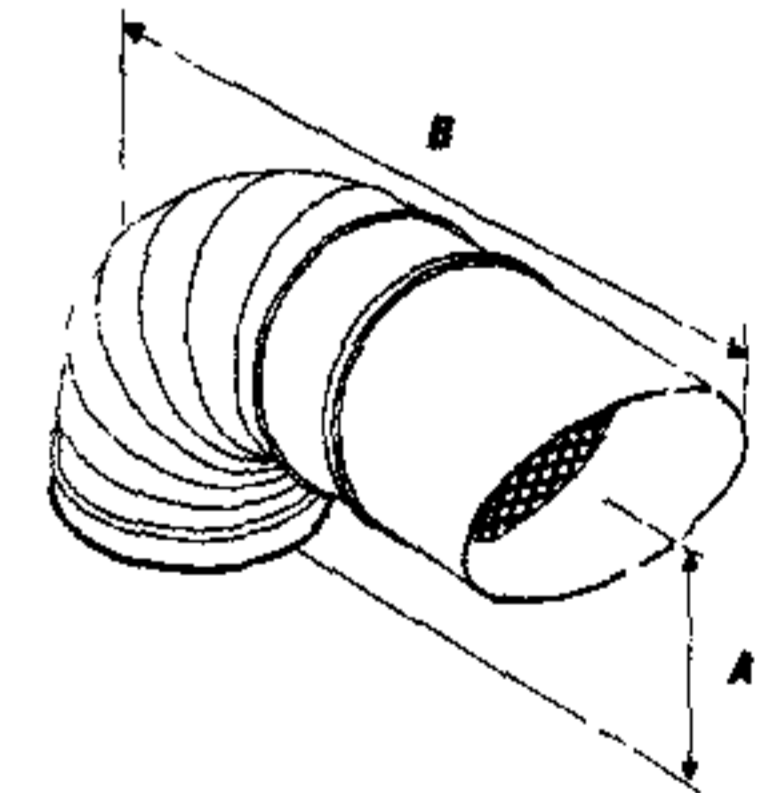

Exhaust Terminal (Horizontal)

Int Ø(mm)	150	180	200	230	250	300	355	405	455	505	555	605
Ext Ø(mm)	200	230	250	280	300	355	405	455	505	555	605	655
'A'	325	355	375	405	425	480	530	580	630	680	730	780

This terminal is designed for all pressure applications where the termination discharges in a horizontal run, and is fitted with a bird guard.

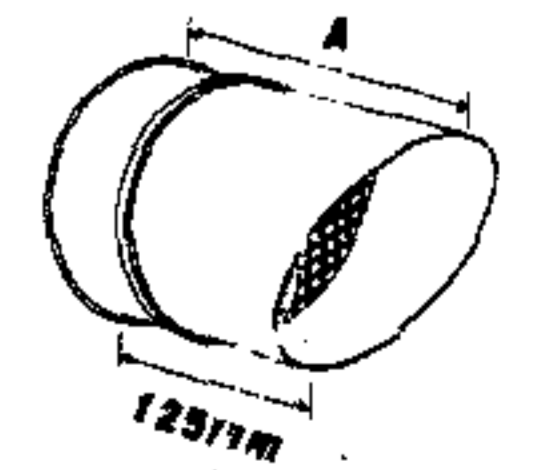

Roof Support

Int. Ø (mm)	150	180	200	230	250	300	355	405	455	505	555	605
Ext. Ø (mm)	200	230	250	280	300	355	405	455	505	555	605	655

This component should be used to support the chimney passing through the roof.

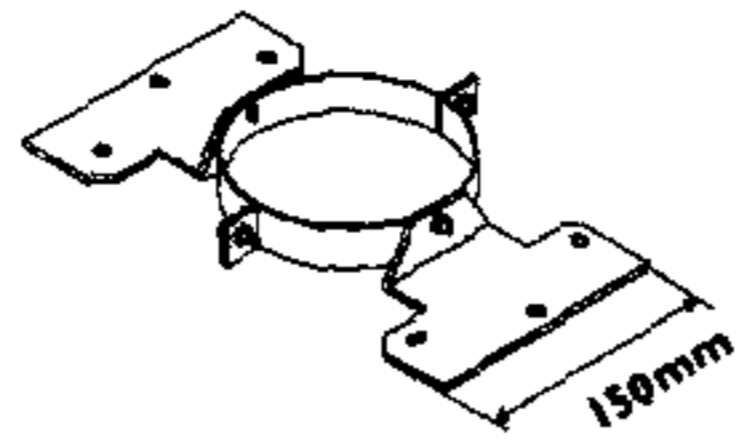

All flashings are provided with a stainless steel storm collar and sealant.

Angled Flashing (5° - 45°)

Int. Ø (mm)	150	180	200	230	250	300
Ext. Ø (mm)	200	230	250	280	300	355
'A'	700	700	700	800	800	860

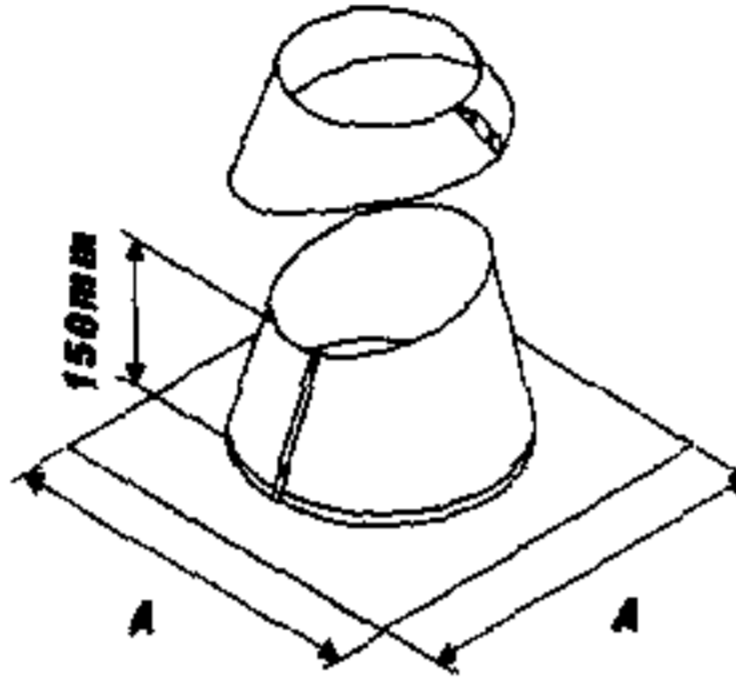

Angled Flashing (5° - 30°)

Int. Ø (mm)	355	405	455	505	555	605
Ext. Ø (mm)	405	455	505	555	605	655
'A'	800	800	900	1000	1000	1100

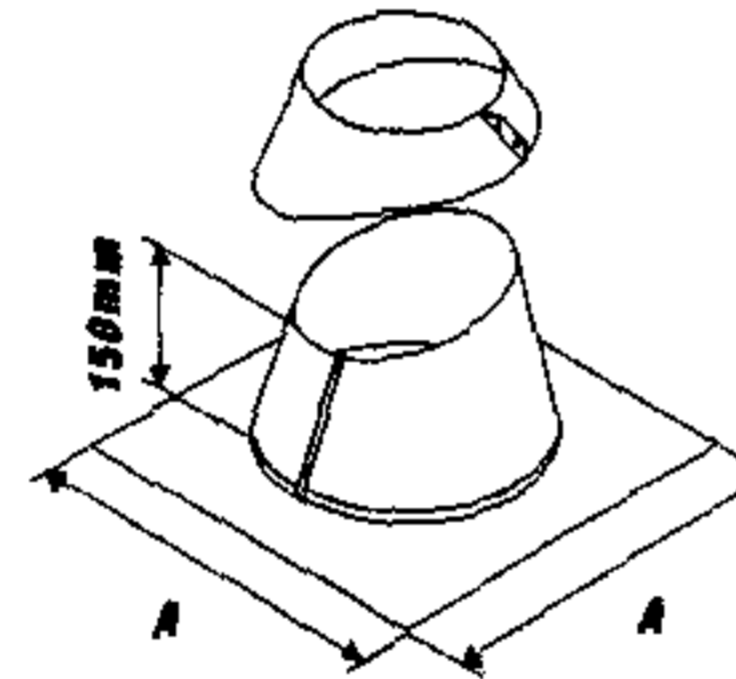

Flat Flashing

Int. Ø (mm)	150	180	200	230	250	300	355	405	455	505	555	605
Ext. Ø (mm)	200	230	250	280	300	355	405	455	505	555	605	655
'A'	610	610	610	610	610	800	800	800	800	1000	1000	1000

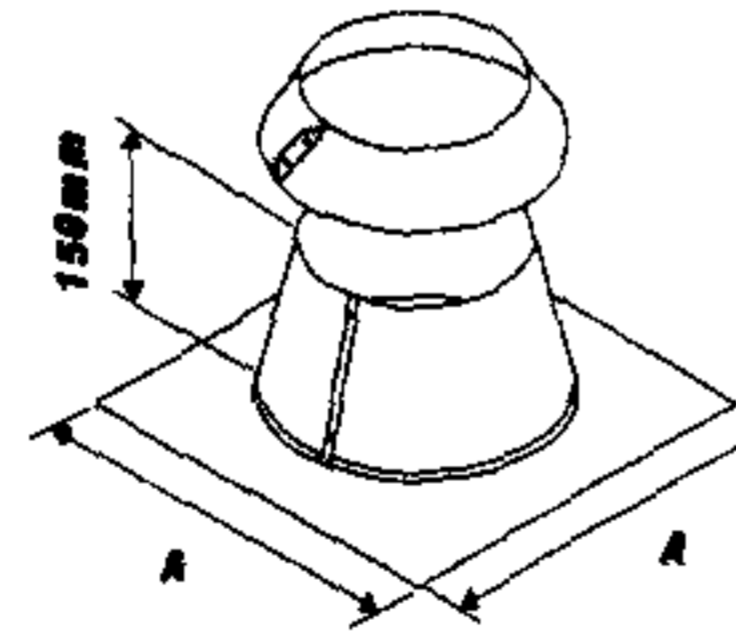

Storm Collar

Stainless steel construction

Int. Ø (mm)	150	180	200	230	250	300	355	405	455	505	555	605
Ext. Ø (mm)	200	230	250	280	300	355	405	455	505	555	605	655



90° Tee

Int. Ø (mm)	150	180	200	230	250	300	355	405	455	505	555	605
Ext. Ø (mm)	200	230	250	280	300	355	405	455	505	555	605	655
'A'	180	195	205	220	230	258	283	308	333	358	383	408
'B'	325	355	375	405	425	480	530	580	630	680	730	780
'C'	180	195	205	220	230	258	283	308	333	358	383	408

Normally used at the base of the vertical stack to provide the facility of a drain point or cleaning access within the system. Where possible, a 135° tee is preferred to minimise restriction of the flue gas flow.

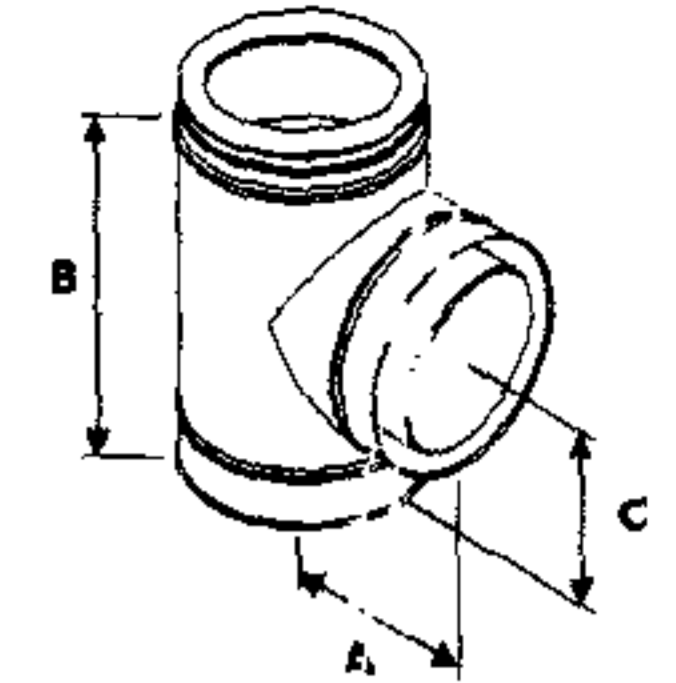

135° Tee

Int. Ø (mm)	150	180	200	230	250	300	355	405	455	505	555	605
Ext. Ø (mm)	200	230	250	280	300	355	405	455	505	555	605	655
'A'	322	358	382	419	443	509	569	620	690	751	811	871
'B'	403	445	474	516	544	622	693	763	834	905	976	1046
'C'	322	358	382	419	443	509	569	620	690	751	811	871

Used as the 90° tee but provides a smooth sweep which minimises restriction of the flue gas flow.

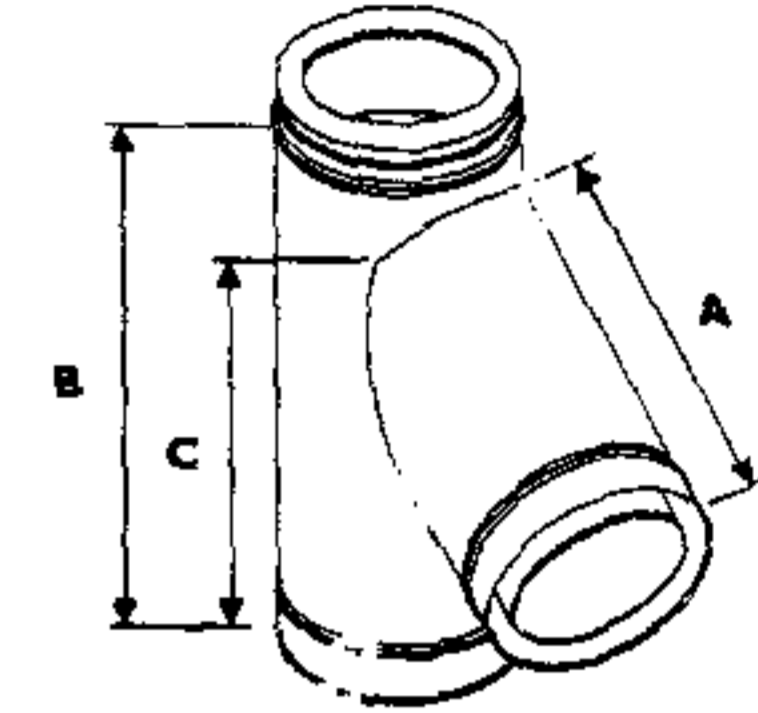

Inspection Tee

Int. Ø (mm)	150	180	200	230	250	300	355	405	455	505	555	605
Ext. Ø (mm)	200	230	250	280	300	355	405	455	505	555	605	655
'A'	180	195	205	220	230	258	283	308	333	358	383	408
'B'	325	355	375	405	425	480	530	580	630	680	730	780
'C'	180	195	205	220	230	258	283	308	333	358	383	408

The inspection tee is supplied complete with a tee plug.

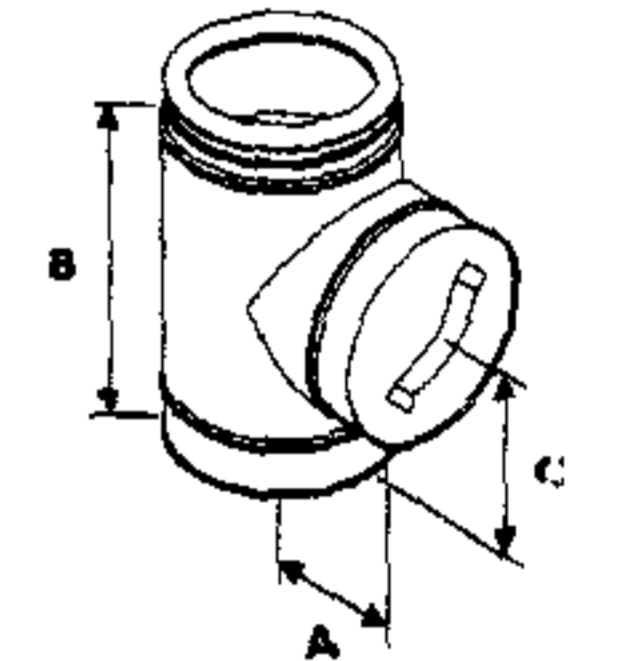

Tee Plug

Int. Ø (mm)	150	180	200	230	250	300	355	405	455	505	555	605
Ext. Ø (mm)	200	230	250	280	300	355	405	455	505	555	605	655



Tee Plug with Drain

Int. Ø (mm)	150	180	200	230	250	300	355	405	455	505	555	605
Ext. Ø (mm)	200	230	250	280	300	355	405	455	505	555	605	655



Where ICS 5000 is to be used internally and penetrating a combustible floor or ceiling, the following support components MUST be used, depending on the application and fuel type.

Firestop Plate

Int. Ø(mm)	150	180	200	230	250	300	355	405	455	505	555	605
Ext. Ø(mm)	200	230	250	280	300	355	405	455	505	555	605	655
'A'	400	430	450	480	500	555	605					
'B'	300	330	350	380	400	455	505					

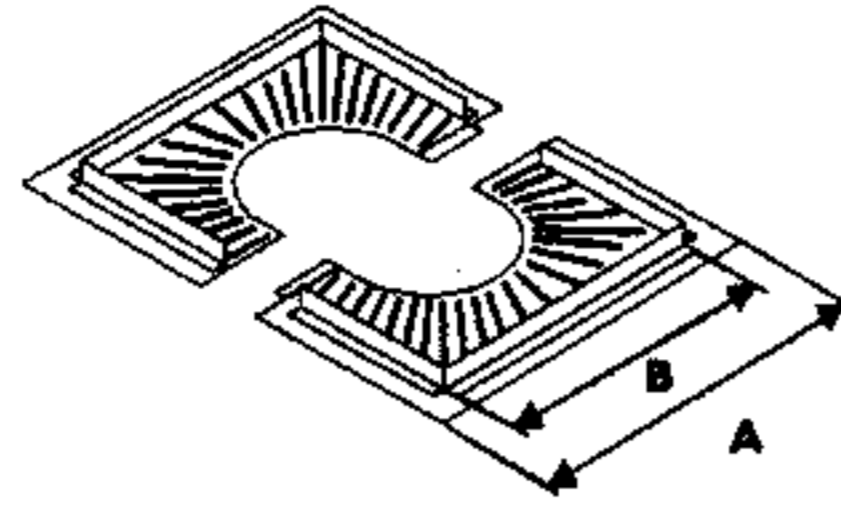

Floor Support Adj. (500mm - 800mm)

Int. Ø(mm)	150	180	200	230	250	300	355	405	455	505	555	605
Ext. Ø(mm)	200	230	250	280	300	355	405	455	505	555	605	655
'A'	290	320	340	370	390	445	495	545	595	645	695	745
'B'	270	300	320	350	370	425	475	525	575	625	675	725

This component is used to support a vertical system from the floor. The floor support must be firmly secured by the nuts and bolts supplied, and separately anchored. The pipe length provided with this component is 75mm.

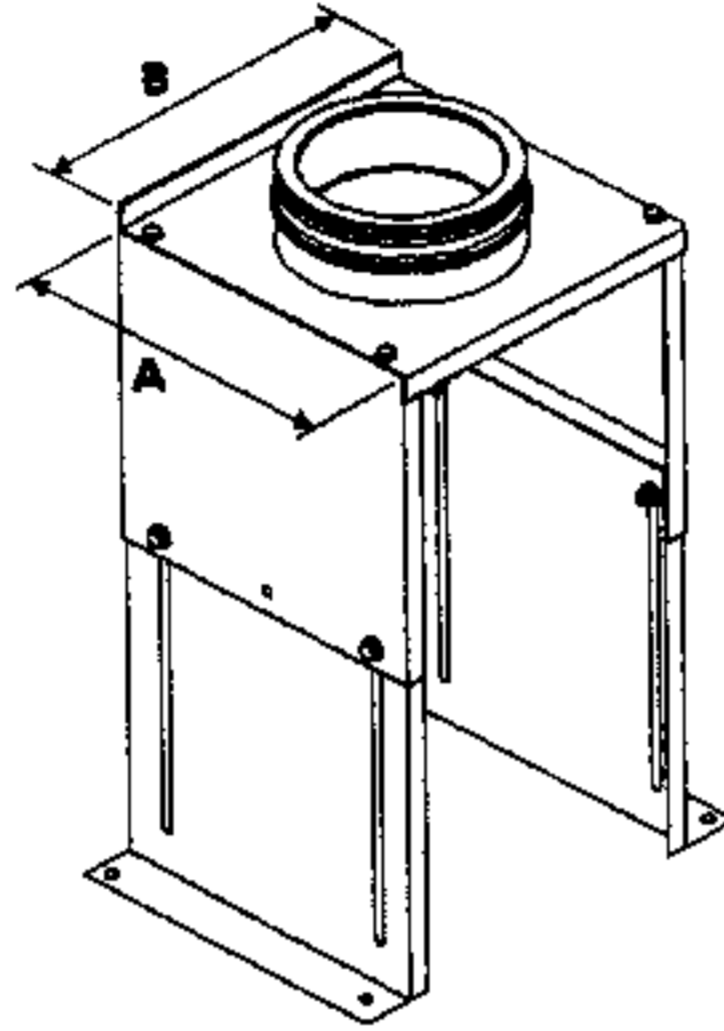

Wall Support

Stainless steel construction.

Int. Ø(mm)	150	180	200	230	250	300	355	405	455	505	555	605
Ext. Ø(mm)	200	230	250	280	300	355	405	455	505	555	605	655
'A'	270	300	320	350	370	425	475	525	575	625	675	725
'B'	470	470	470	470	470	670	670	670	670	870	870	870
'C'	190	320	340	370	390	445	495	545	595	645	695	745
'D'	150	165	175	190	200	228	253	278	303	328	353	378

This component can be used as a base or intermediate support. The pipe length provided with this component is 167mm.

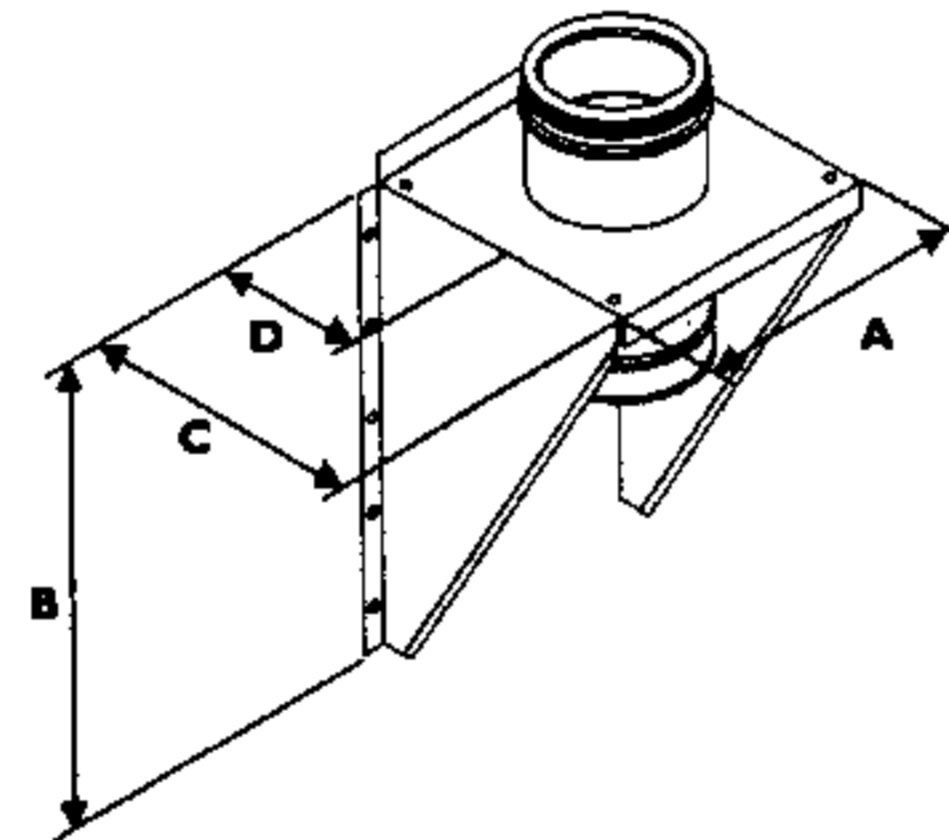

Adj. Ceiling Support

Int. Ø(mm)	150	180	200	230	250	300	355	405	455	505	555	605
Ext. Ø(mm)	200	230	250	280	300	355	405	455	505	555	605	655
'A'	270	300	320	350	370	425	475	525	575	625	675	725
'B'	290	320	340	370	390	445	495	545	595	645	695	745
'C'	600	630	650	680	700	755	805	855	905	955	1005	1055

The pipe length provided with this component is 167mm.

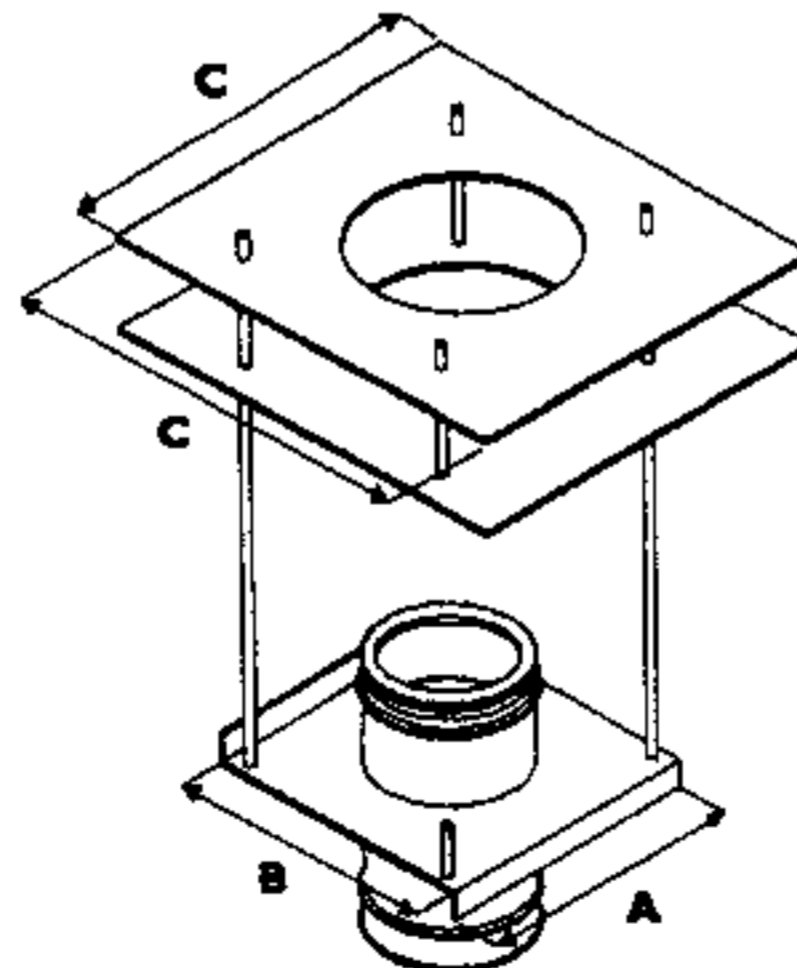

Base Support Plate with Drain

Int. Ø(mm)	150	180	200	230	250	300	355	405	455	505	555	605
Ext. Ø(mm)	200	230	250	280	300	355	405	455	505	555	605	655
'A'	300	330	350	380	400	455	505	555	605	655	705	755

This component must NOT be used in conjunction with a pressure system.

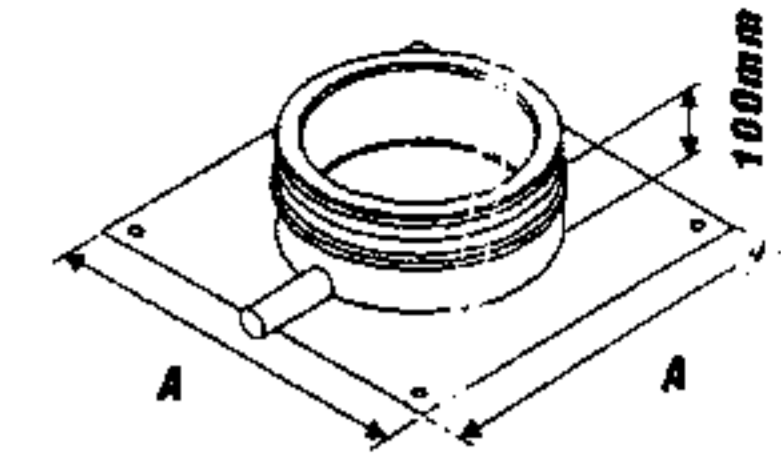

Wall Sleeve

Int. Ø(mm)	150	180	200	230	250	300	355	405	455	505	555	605
Ext. Ø(mm)	200	230	250	280	300	355	405	455	505	555	605	655
'A'	250	280	300	330	350	405	455	505	555	605	655	705

This component must be used where the chimney is passing through an external wall. It is supplied 400mm long to enable on-site cutting as appropriate.

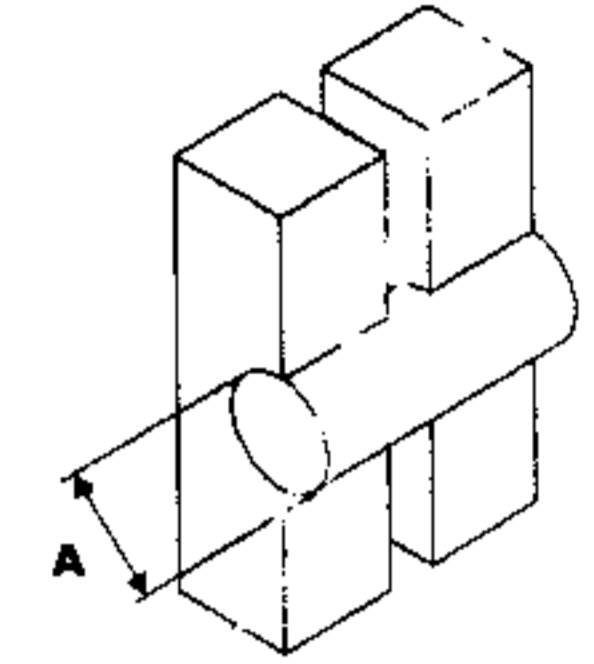

Ceiling Hanger

Int. Ø(mm)	150	180	200	230	250	300	355	405	455	505	555	605
Ext. Ø(mm)	200	230	250	280	300	355	405	455	505	555	605	655

This component is designed to support horizontal runs of chimney from the roof or ceiling.

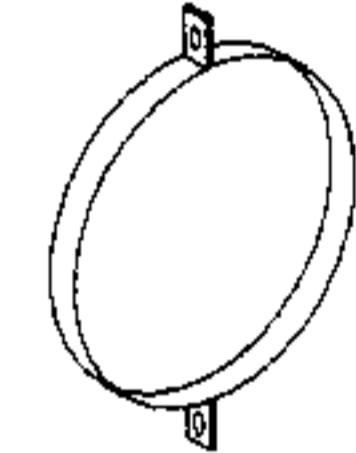

Wall Bracket 50mm

Stainless steel construction.

Int. Ø(mm)	150	180	200	230	250	300	355	405	455	505	555	605
Ext. Ø(mm)	200	230	250	280	300	355	405	455	505	555	605	655
'A'	190	228	248	278	298	353	403	453	503	551	601	653
'B'	150	165	175	190	200	228	253	278	303	328	353	378

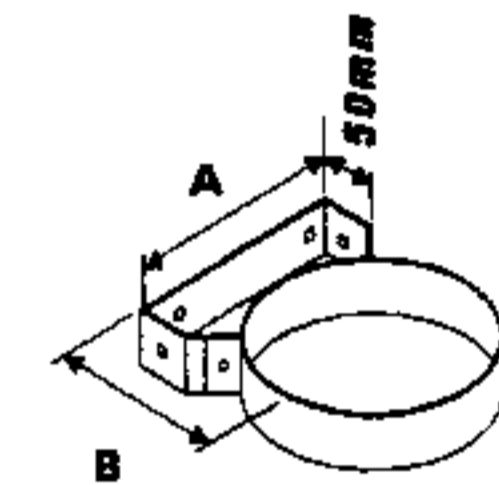

Wall Bracket 300mm (Adj.)

Stainless steel construction.

Int. Ø(mm)	150	180	200	230	250	300	355	405	455	505	555	605
Ext. Ø(mm)	200	230	250	280	300	355	405	455	505	555	605	655
'A'	201	231	251	281	301	356	406	456	506	557	607	657

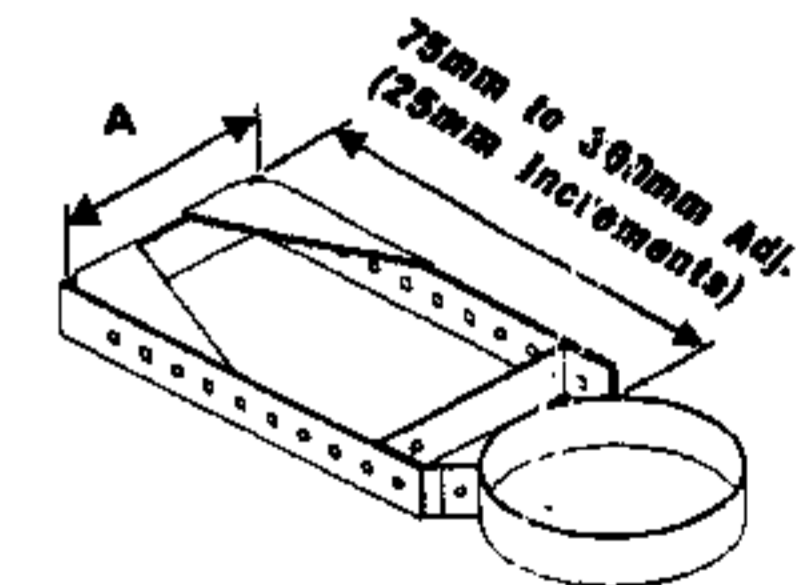

Guy Wire Bracket

Int. Ø(mm)	150	180	200	230	250	300	355	405	455	505	555	605
Ext. Ø(mm)	200	230	250	280	300	355	405	455	505	555	605	655

This component should be used to support a chimney section, the maximum unsupported length being 1.5m.

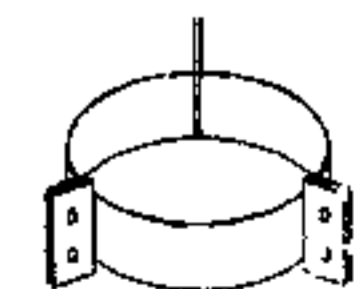

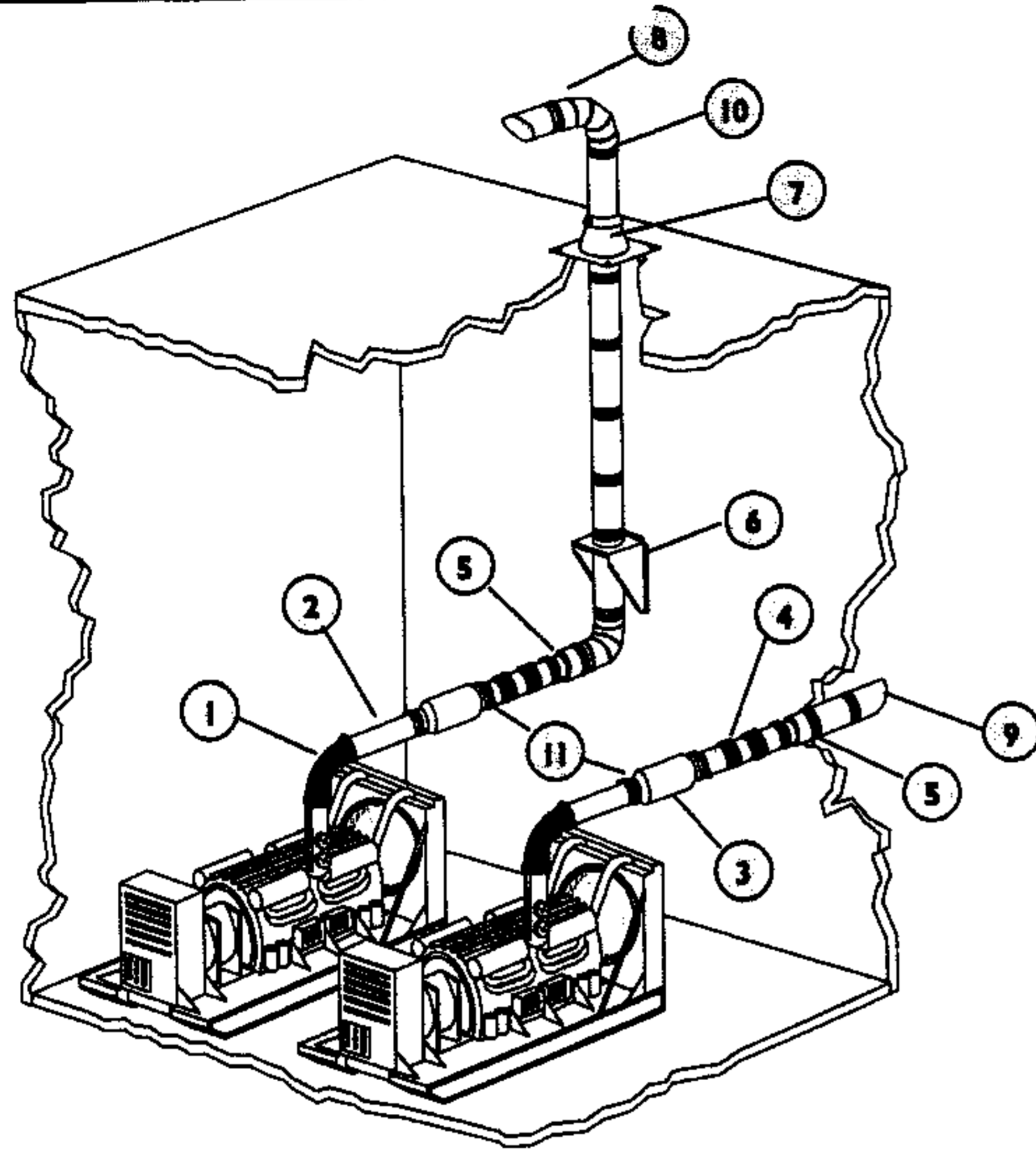

Item No.	Description	Item Ref.
①	Flexible Connector (by others)	-
②	Flanged Pipe	J2405
③	Silencer (by others)	-
④	Double Bellows	J2428
⑤	Flanged Adaptor to ICS 5000	J2445
⑥	Wall Support	J2482
⑦	Flat Flashing	9553
⑧	Exhaust Terminal (vertical)	J2414
⑨	Exhaust Terminal (horizontal)	J2439
⑩	Terminal Section	J2435
⑪	'V' Band (supplied with flanged pipe)	-

The above drawing does not typify an actual installation, but is a representation using components detailed within this brochure.

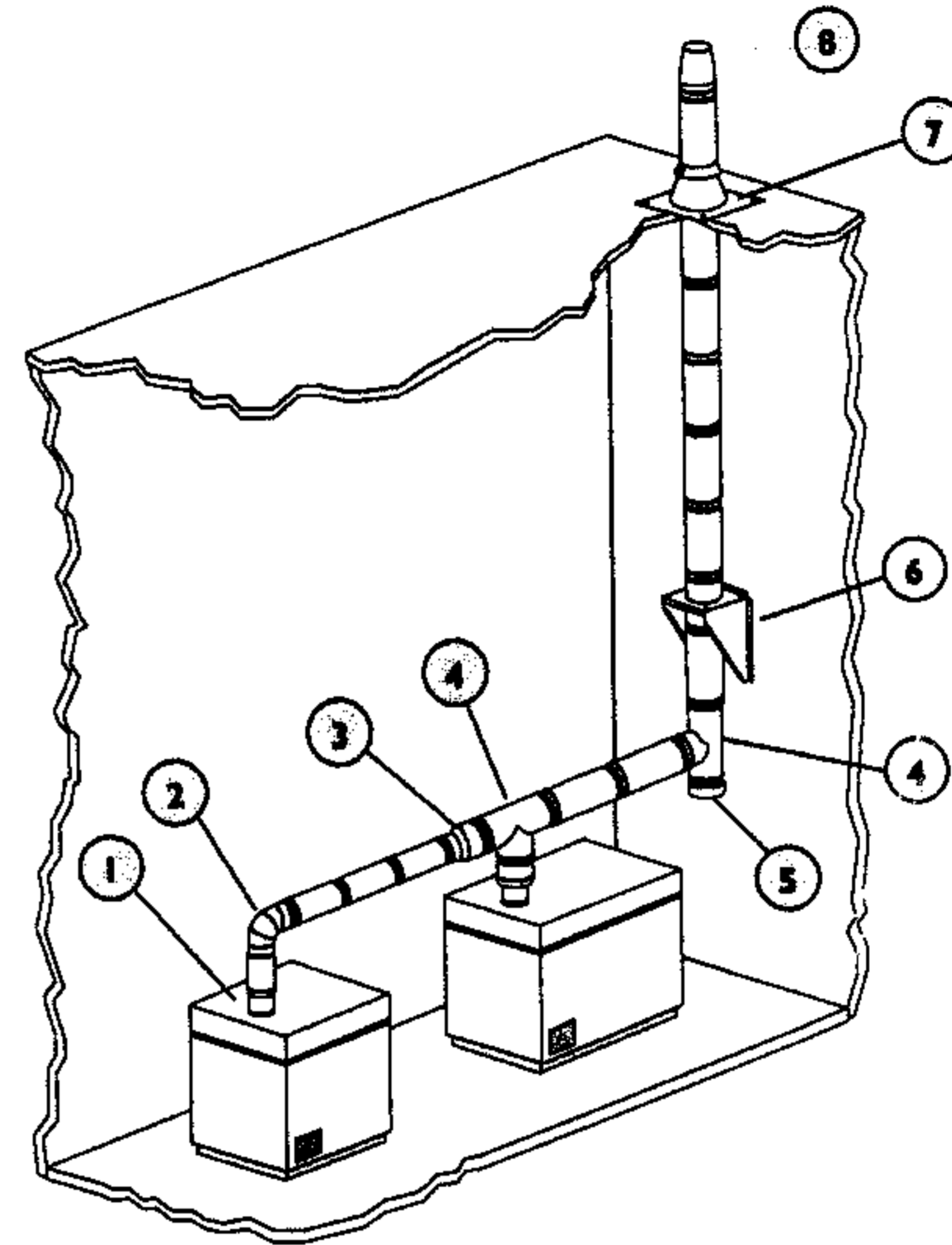

Item No.	Description	Item Ref.
①	Appliance Connector	J2446
②	90° Bend	J2415
③	Increaser	J2471
④	90° Tee	J2420
⑤	Tee Plug	J2425
⑥	Wall Support	J2482
⑦	Flat Flashing	9553
⑧	Tapered Terminal	J2138

The above drawing does not typify an actual installation, but is a representation using components detailed within this brochure.

RITE-VENT

Flues and Chimneys

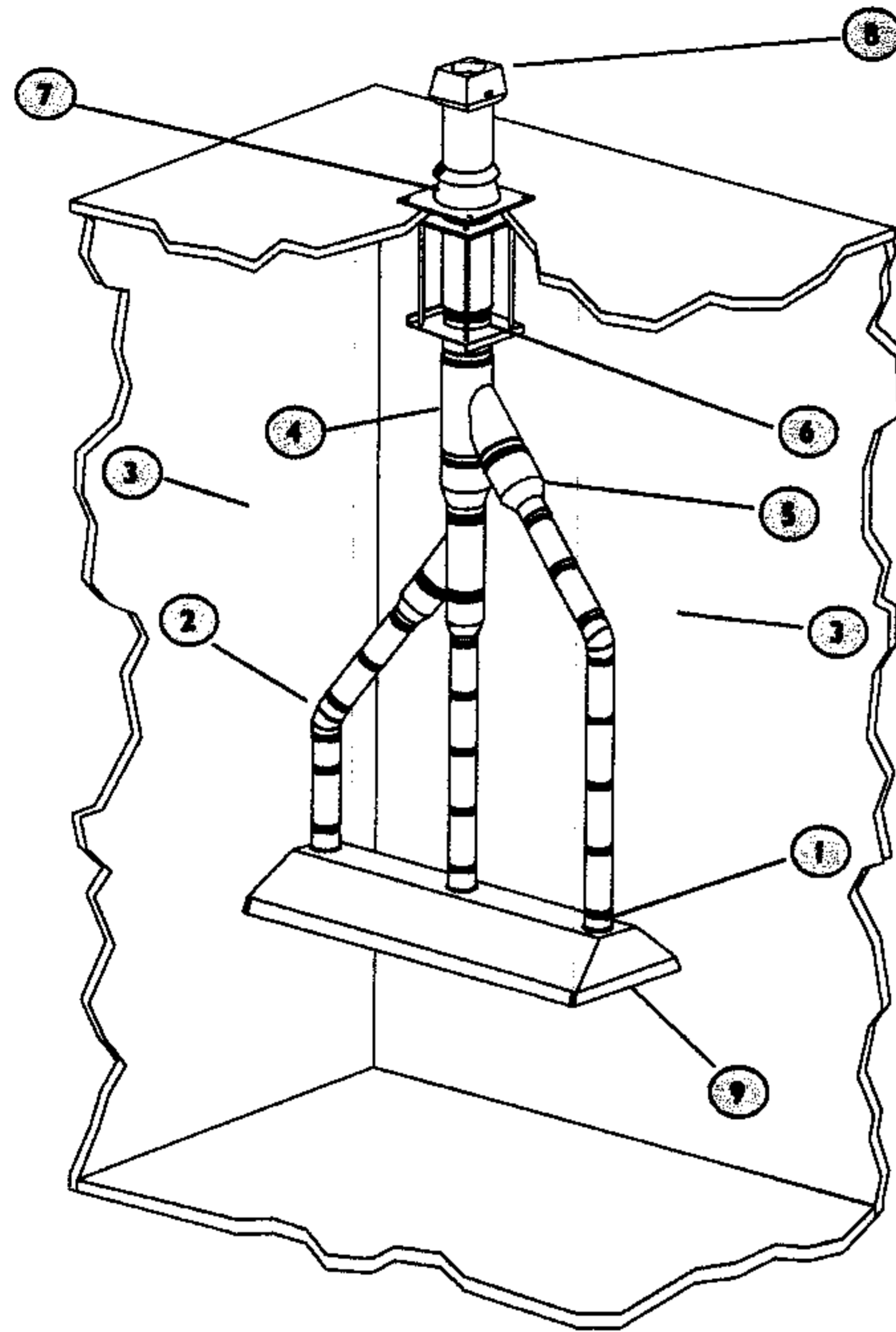

Item No.	Description	Item Ref
①	Appliance Connector	J2446
②	45° Bend	J2417
③	Drop Rods (by others)	-
④	135° Tee	J2421
⑤	Increaser	J2471
⑥	Adj. Ceiling Support	J2492
⑦	Flat Flashing	9553
⑧	Extract Fan (by others)	-
⑨	Extract Hood (by others)	-

The above drawing does not typify an actual installation, but is a representation using components detailed within this brochure.



Universal stainless steel 316L grade single wall system for use as:

- Flue liner for multi fuel applications
- Semi and fully condensing appliances
- Gas and oil flue system

Insulated chimney range for industrial, commercial and residential use on all fuel applications.

Insulated stainless steel twin wall system for use on low temperature appliances where condensation will occur.



RITE-VENT LTD., CROWTHER ESTATE, WASHINGTON, TYNE & WEAR, NE38 0AQ.
TELEPHONE: +44 (0)191 416 1150 FAX: +44 (0)191 415 1263
E-MAIL: sales@rite-vent.co.uk WEB SITE: www.rite-vent.co.uk

As part of our continual research and product innovation programme we reserve the right to alter/modify components shown in this catalogue without prior notice.
 ISSUE 2 IC 3000