

THIS DRAWING AND CAD DATA THEREIN IS PROTECTED BY COPYRIGHT AND MUST NOT BE COPIED OR REPRODUCED WITHOUT THE WRITTEN CONSENT OF DAMOND LOCK GRABOWSKI + PARTNERS.

©
NO DIMENSIONS ARE TO BE SCALED FROM THIS DRAWING. USE FIGURED DIMENSIONS ONLY. ALL DIMENSIONS AND SIZES ARE TO BE CHECKED ON SITE AND ANY DISCREPANCIES REPORTED TO THE ARCHITECT PRIOR TO INITIATION OF ANY WORKS.

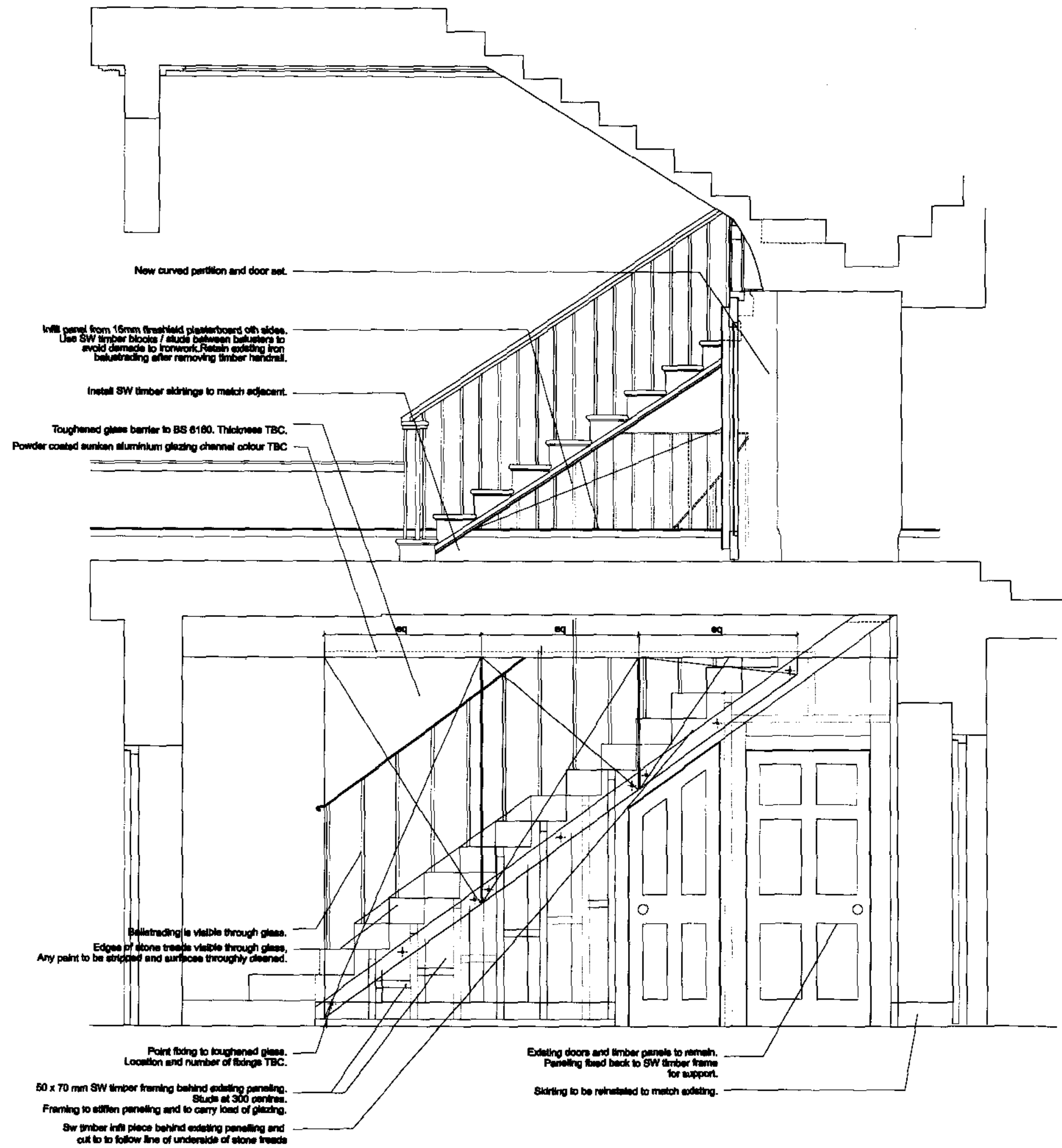

1 - Section through Hallway

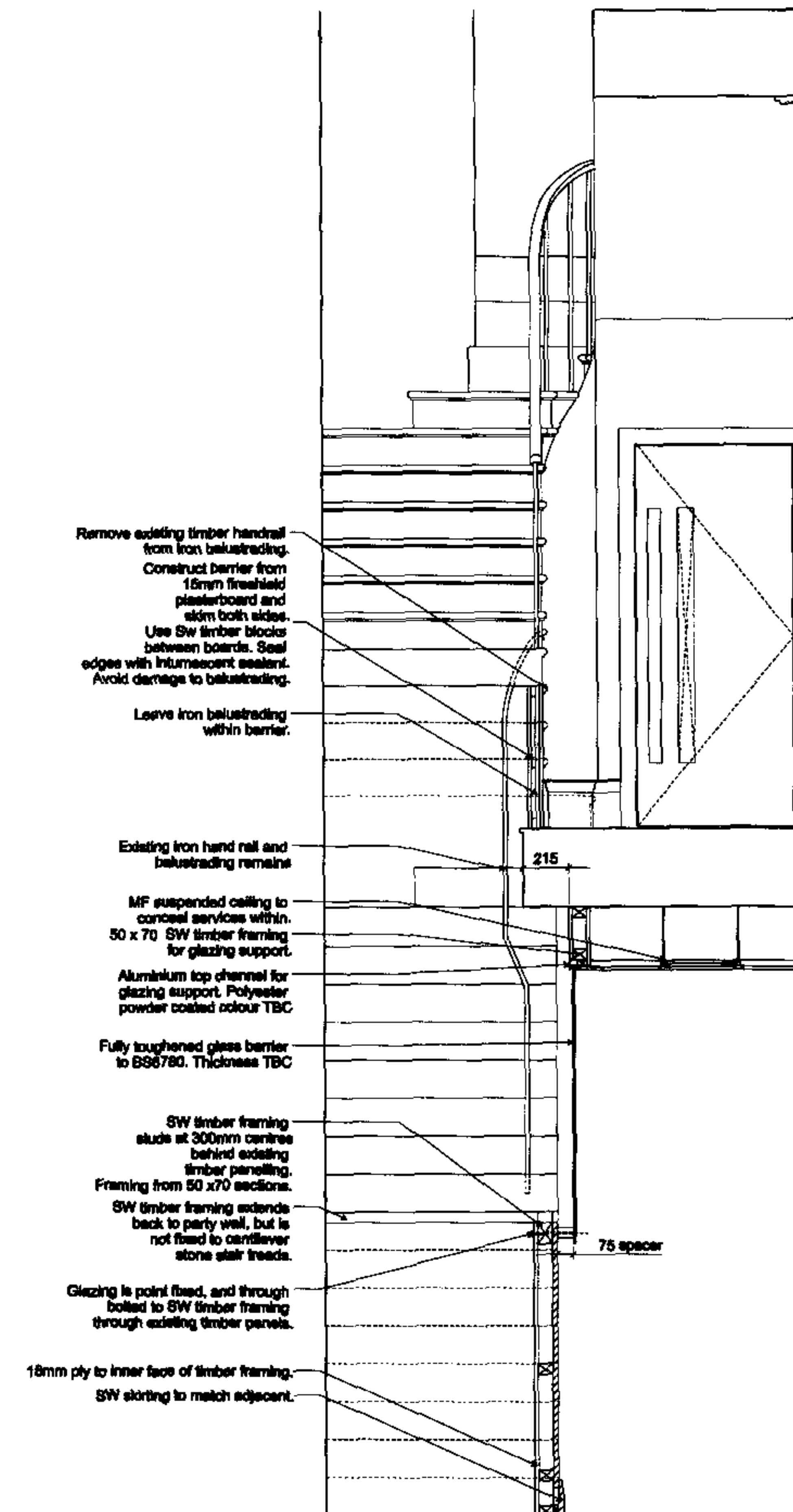

2 - Section towards Apartment entrance

07.04.20 General revisions fc A
Date Init. Rev.

Job
26/27 Bloomsbury Square
London
WC1

Drawing Title
No. 26 Bloomsbury Square
Proposed Basement Hallway
Glazed Barrier

Status
PLANNING

Date Drawn Scale
03.07 fc 1:20@A1

Job No.	Drawing ref.	Drawing No.	Revision
3113	P (73)	001	A

DLG Architects
11-29 Fashion Street
London E1 6PZ

t +44(0)20 7426 3630
f +44(0)20 7426 3631
london@dlgarchitects.com

dlgarchitects.com



THIS DRAWING AND CAD DATA THEREIN IS PROTECTED BY COPYRIGHT AND MUST NOT BE COPIED OR REPRODUCED WITHOUT THE WRITTEN CONSENT OF DAMOND LOCK GRABOWSKI + PARTNERS.

NO DIMENSIONS ARE TO BE SCALED FROM THIS DRAWING. USE FIGURED DIMENSIONS ONLY. ALL DIMENSIONS AND SIZES ARE TO BE CHECKED ON SITE AND ANY DISCREPANCIES REPORTED TO THE ARCHITECT PRIOR TO INITIATION OF ANY WORKS.

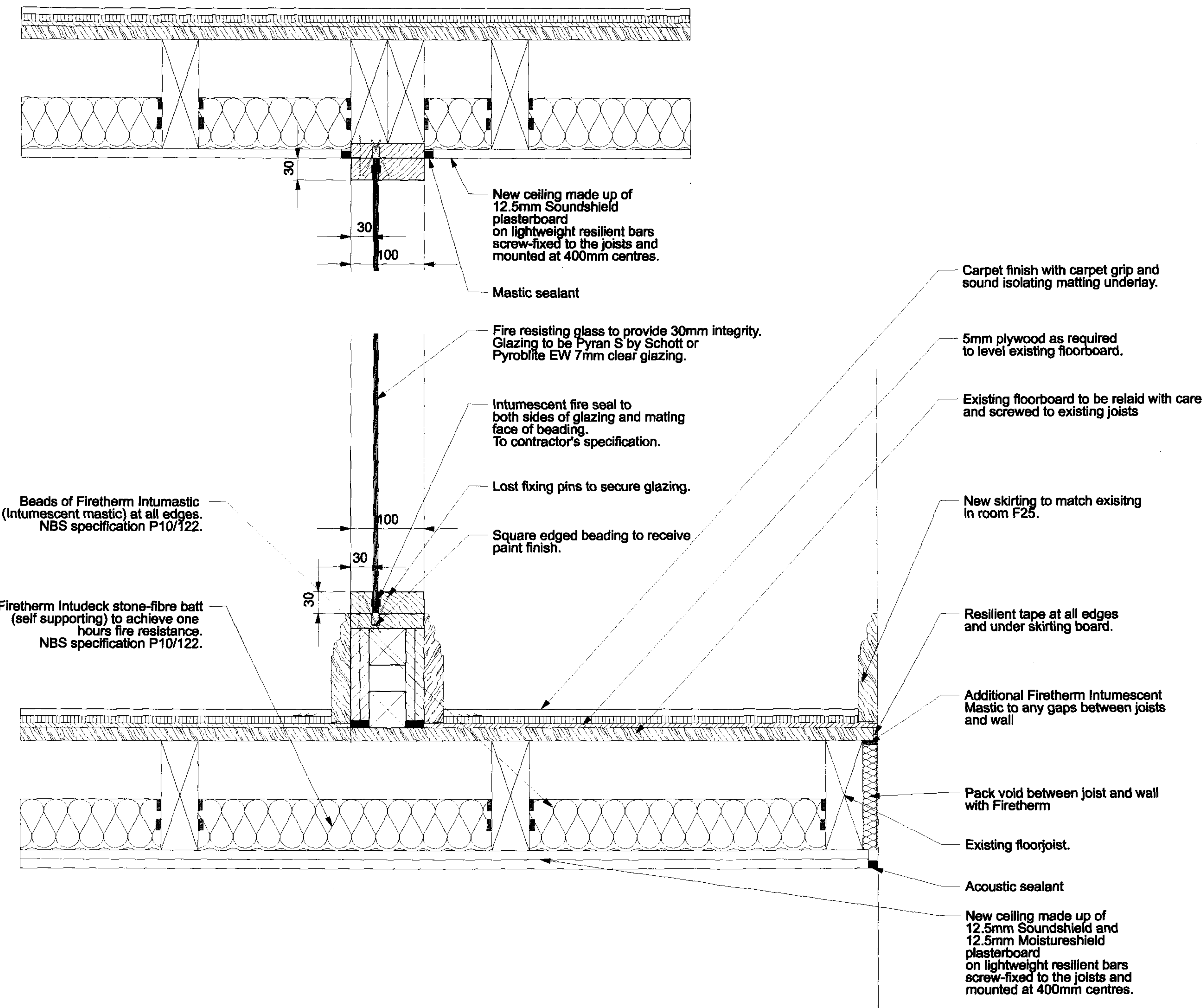

New ceiling made up of 12.5mm Soundshield plasterboard on lightweight resilient bars screw-fixed to the joists and mounted at 400mm centres.

Mastic sealant

Fire resisting glass to provide 30mm integrity. Glazing to be Pyran S by Schott or Pyroblite EW 7mm clear glazing.

Intumescent fire seal to both sides of glazing and mating face of beading. To contractor's specification.

Lost fixing pins to secure glazing.

Square edged beading to receive paint finish.

Beads of Firetherm Intumastic (Intumescent mastic) at all edges. NBS specification P10/122.

Firetherm Intudeck stone-fibre batt (self supporting) to achieve one hours fire resistance. NBS specification P10/122.

Carpet finish with carpet grip and sound isolating matting underlay.

5mm plywood as required to level existing floorboard.

Existing floorboard to be relaid with care and screwed to existing joists

New skirting to match existing in room F25.

Resilient tape at all edges and under skirting board.

Additional Firetherm Intumescent Mastic to any gaps between joists and wall

Pack void between joist and wall with Firetherm

Existing floorjoist.

Acoustic sealant

New ceiling made up of 12.5mm Soundshield and 12.5mm Moistureshield plasterboard on lightweight resilient bars screw-fixed to the joists and mounted at 400mm centres.

Date	Init.	Rev.

Job
26/27 Bloomsbury Square
London
WC1

Drawing Title
No 27 - Room F27
Glazed Fire barrier
Detail

Status
Construction

Date	Drawn	Scale
May 07	fc	1:5@A3

Job No.	Drawing ref.	Drawing No.	Revision
3113	P(73)	152	-

DLG Architects
11-29 Fashion Street
London E1 6PZ

t +44(0)20 7426 3630
f +44(0)20 7426 3631
london@dlgarchitects.com

dlgarchitects.com



THIS DRAWING AND CAD DATA THEREIN IS PROTECTED BY COPYRIGHT AND MUST NOT BE COPIED OR REPRODUCED WITHOUT THE WRITTEN CONSENT OF DAMOND LOCK GRABOWSKI + PARTNERS.

©

NO DIMENSIONS ARE TO BE SCALED FROM THIS DRAWING. USE FIGURED DIMENSIONS ONLY. ALL DIMENSIONS AND SIZES ARE TO BE CHECKED ON SITE AND ANY DISCREPANCIES REPORTED TO THE ARCHITECT PRIOR TO INITIATION OF ANY WORKS.

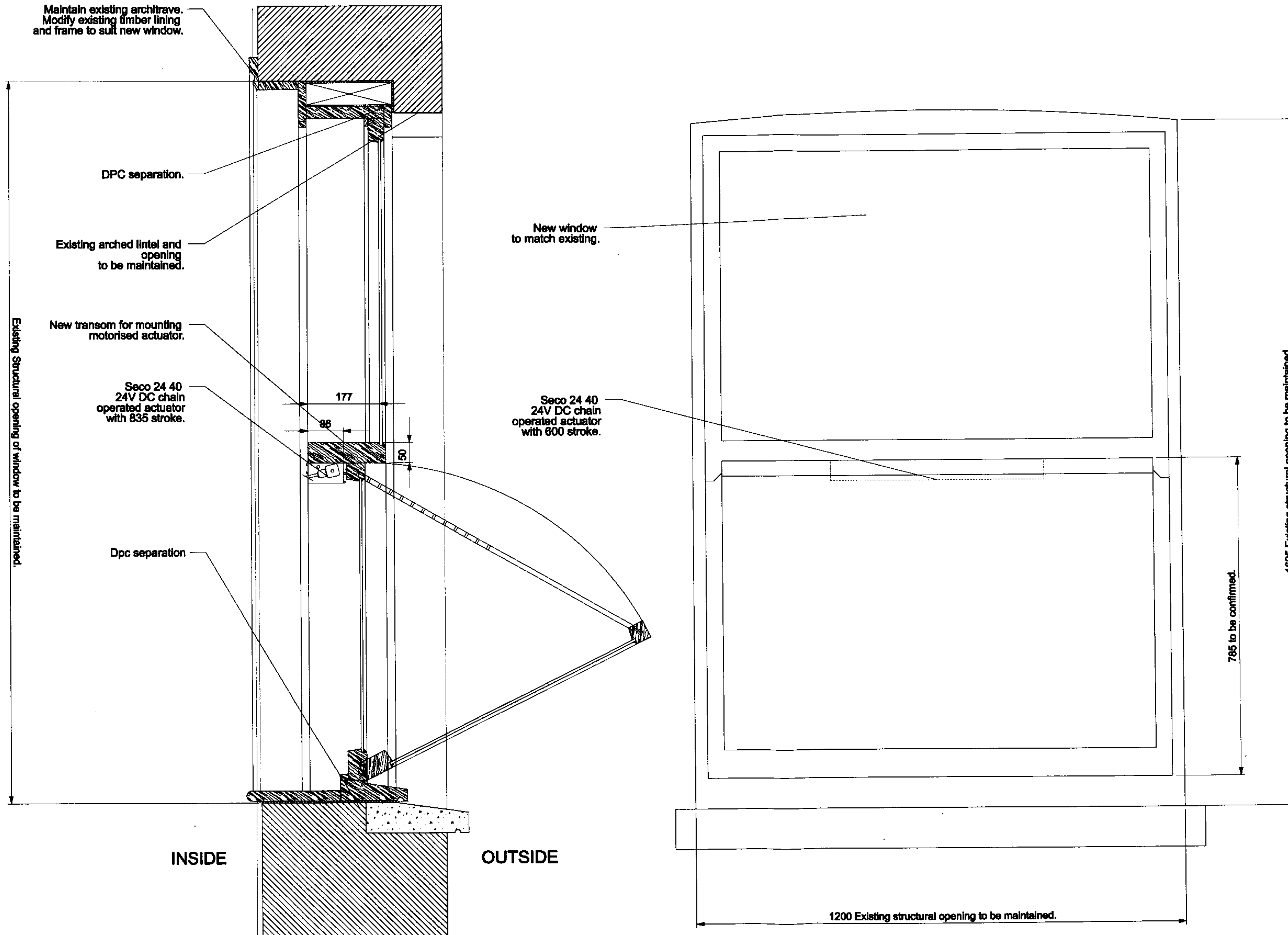

Date _____ Init. Rev.

Job
**26/27 Bloomsbury Square
 London
 WC1**

Drawing Title
Window WS08

Status
Planning

Date	Drawn	Scale
Jul 07	fc	1:10@A3

Job No.	Drawing ref.	Drawing No.	Revision
3113	P(31)	105	-

DLG Architects
 11-29 Fashion Street
 London E1 6PZ

t +44(0)20 7426 3630
 f +44(0)20 7426 3631
 london@dlgarchitects.com

dlgarchitects.com



THIS DRAWING AND CAD DATA THEREIN
IS PROTECTED BY COPYRIGHT
AND MUST NOT BE COPIED OR REPRODUCED
WITHOUT THE WRITTEN CONSENT OF
DAMOND LOCK GRABOWSKI + PARTNERS.

©
NO DIMENSIONS ARE TO BE SCALED
FROM THIS DRAWING.
USE FIGURED DIMENSIONS ONLY.
ALL DIMENSIONS AND SIZES
ARE TO BE CHECKED ON SITE
AND ANY DISCREPANCIES REPORTED
TO THE ARCHITECT PRIOR TO
INITIATION OF ANY WORKS.

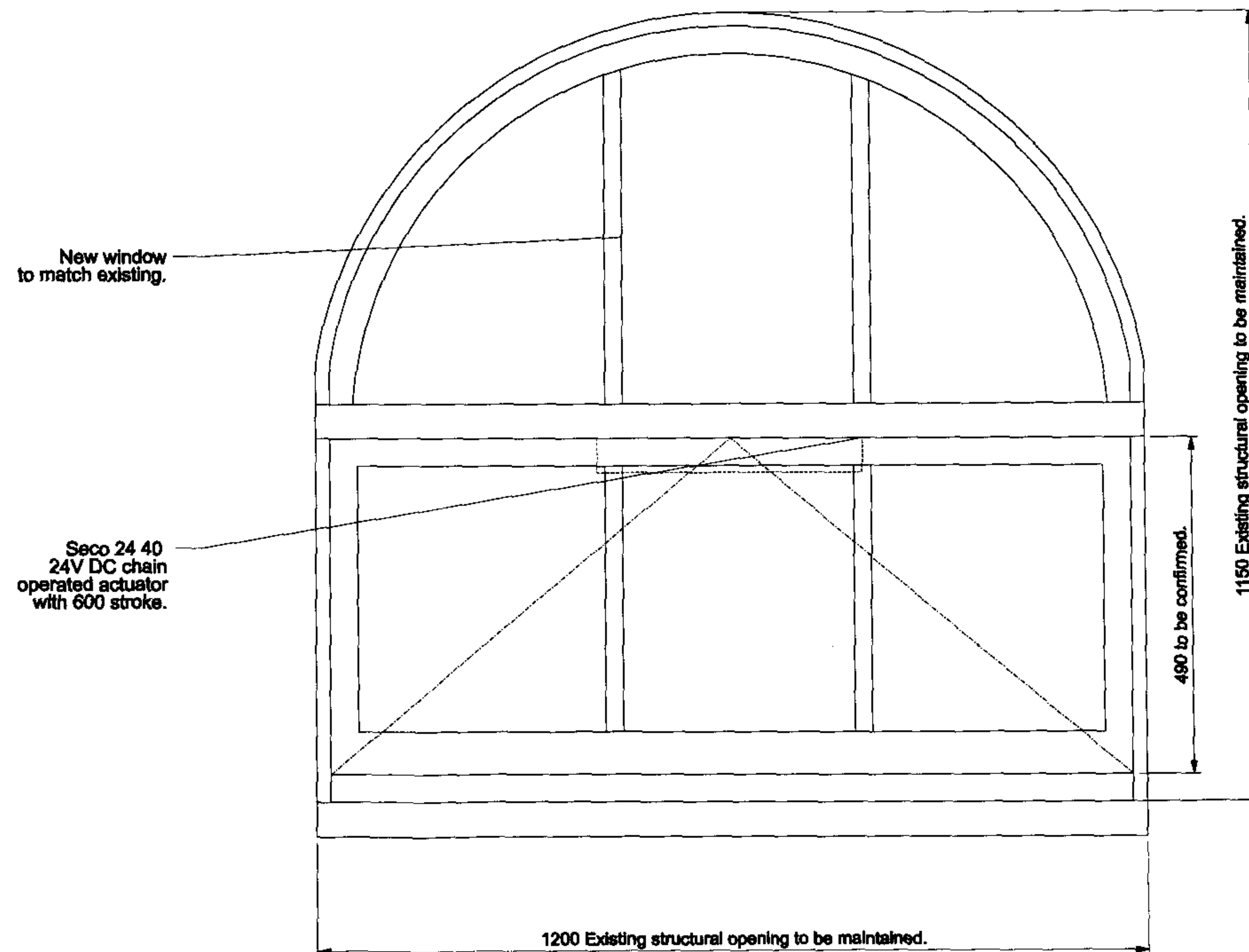
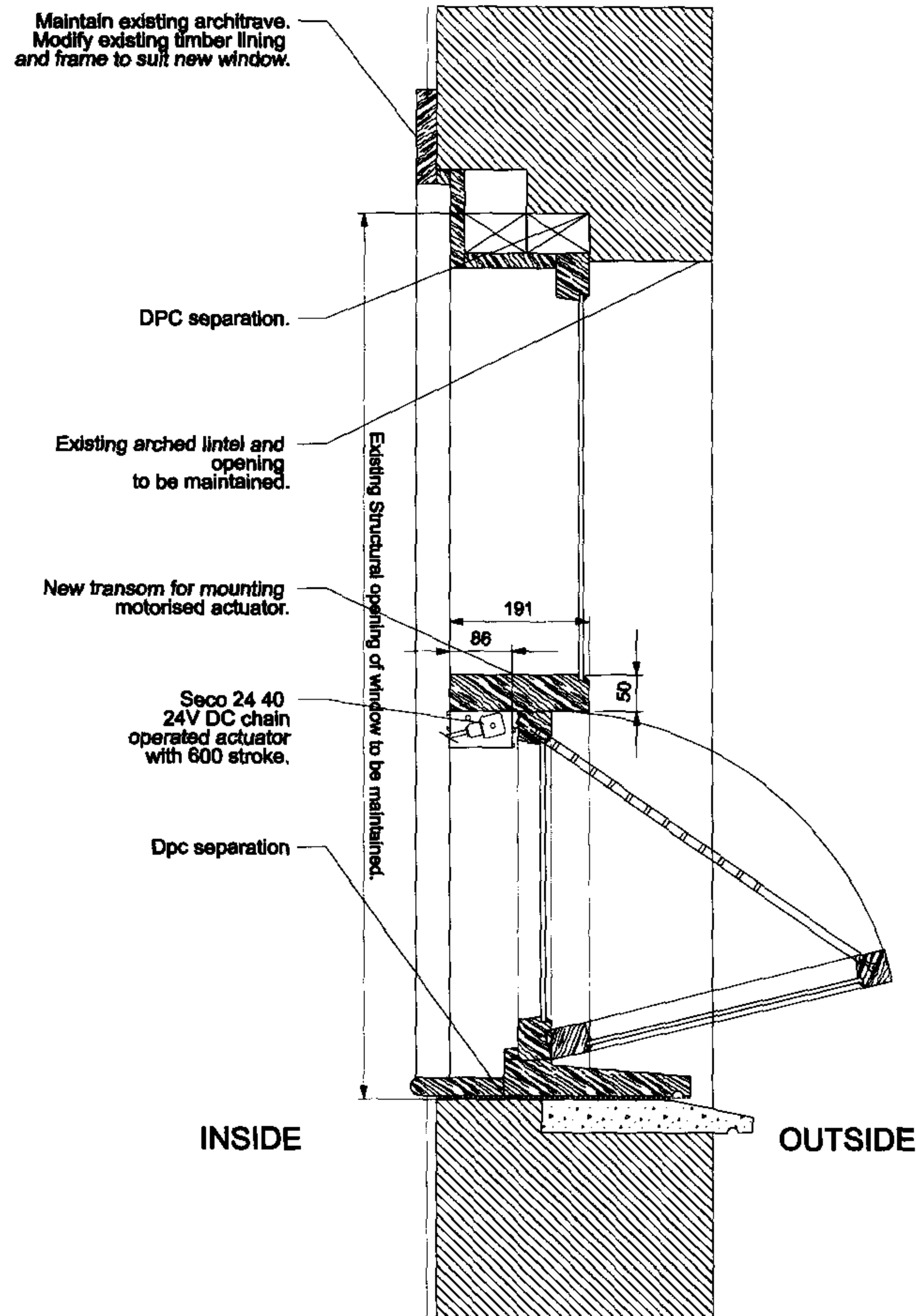

Date _____ Init. Rev.

Job
26/27 Bloomsbury Square
London
WC1

Drawing Title
Window WS27

Status
Planning

Date _____ Drawn _____ Scale
Jul 07 fc 1:10@A3

Job No.	Drawing ref.	Drawing No.	Revision
3113	P(31)	207	-

DLG Architects
11-29 Fashion Street
London E1 6PZ

t +44(0)20 7426 3630
f +44(0)20 7426 3631
london@dlgarchitects.com

dlgarchitects.com



THIS DRAWING AND CAD DATA THEREIN
IS PROTECTED BY COPYRIGHT
AND MUST NOT BE COPIED OR REPRODUCED
WITHOUT THE WRITTEN CONSENT OF
DAMOND LOCK GRABOWSKI + PARTNERS.

©

NO DIMENSIONS ARE TO BE SCALED
FROM THIS DRAWING.
USE FIGURED DIMENSIONS ONLY.
ALL DIMENSIONS AND SIZES
ARE TO BE CHECKED ON SITE
AND ANY DISCREPANCIES REPORTED
TO THE ARCHITECT PRIOR TO
INITIATION OF ANY WORKS.

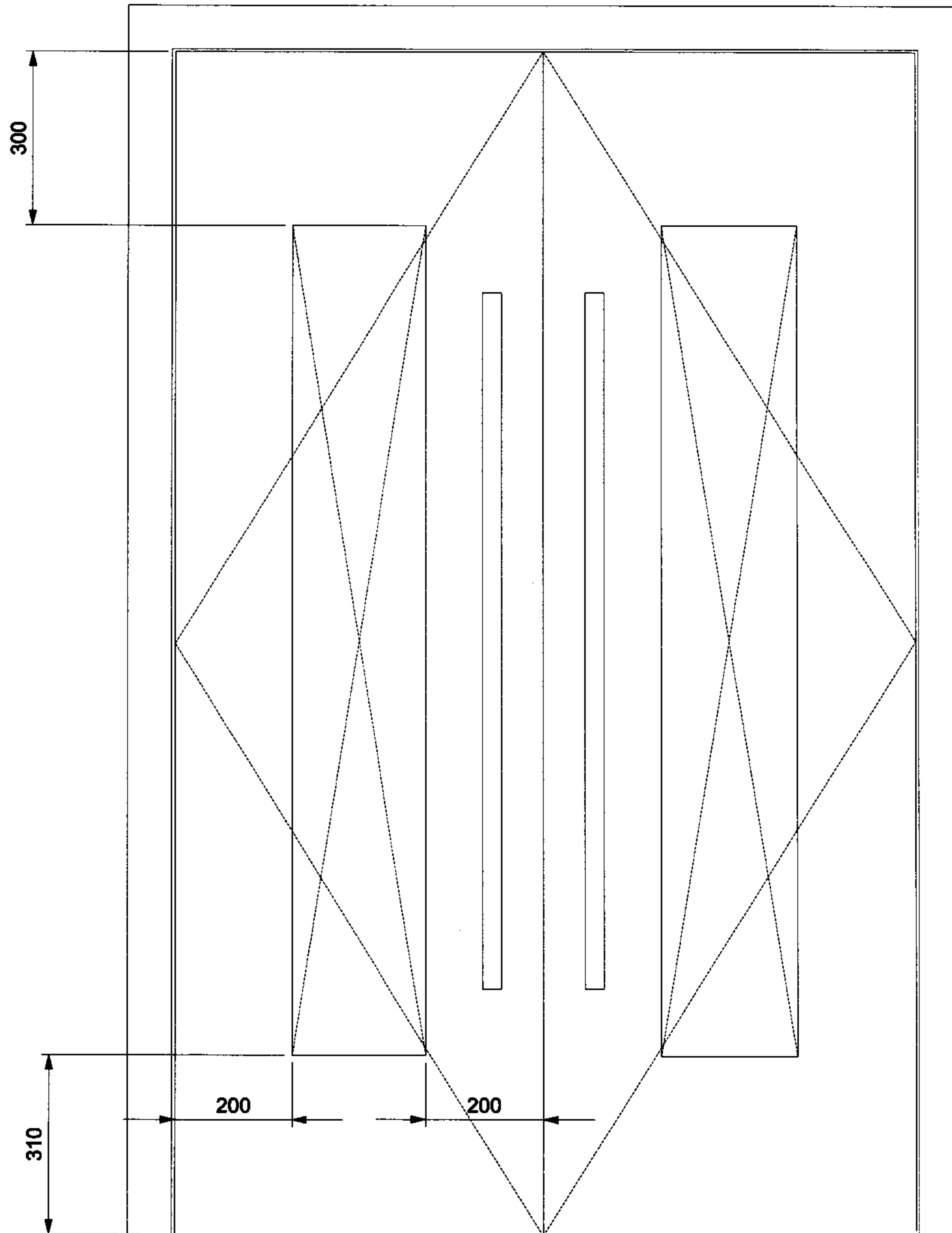

Type F - New flush door with
oblong view panel
Location:
No. 26 Main building - Ground Floor

07.10.01 Dimensions added. fc A
Date Init. Rev.

Job
26/27 Bloomsbury Square
London
WC1

Drawing Title
Door Type F

Status
Construction

Date Drawn Scale
Mar 07 fc 1:10@A3

Job No.	Drawing ref.	Drawing No.	Revision
3113	P(32)	110	A

DLG Architects
11-29 Fashion Street
London E1 6PZ

t +44(0)20 7426 3630
f +44(0)20 7426 3631
london@dlgarchitects.com

dlgarchitects.com

architects
dlg 

THIS DRAWING AND CAD DATA THEREIN IS PROTECTED BY COPYRIGHT AND MUST NOT BE COPIED OR REPRODUCED WITHOUT THE WRITTEN CONSENT OF DAMOND LOCK GRABOWSKI + PARTNERS.

©
NO DIMENSIONS ARE TO BE SCALED FROM THIS DRAWING. USE FIGURED DIMENSIONS ONLY. ALL DIMENSIONS AND SIZES ARE TO BE CHECKED ON SITE AND ANY DISCREPANCIES REPORTED TO THE ARCHITECT PRIOR TO INITIATION OF ANY WORKS.

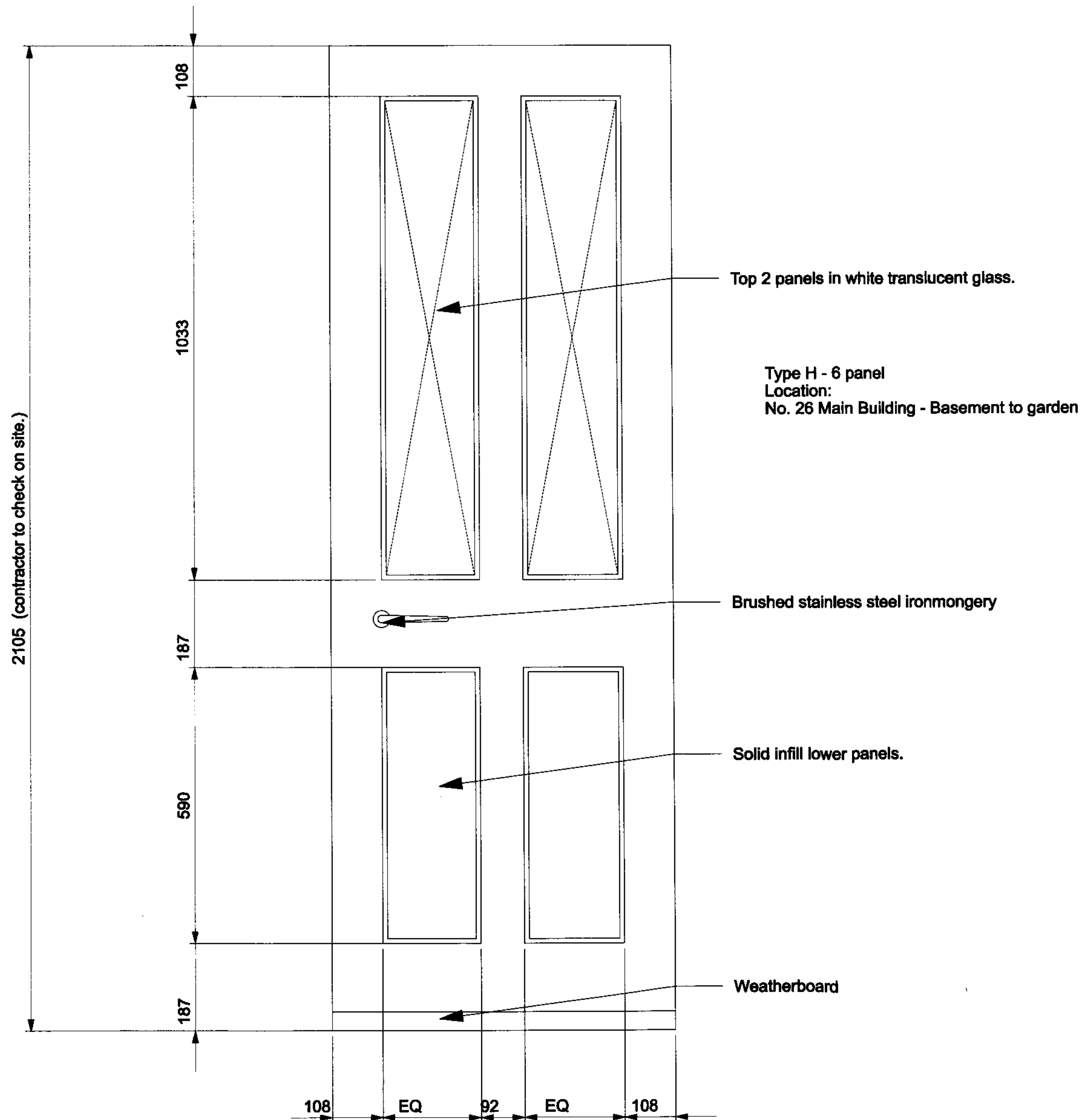

Date _____ Init. _____ Rev. _____

Job
26/27 Bloomsbury Square
London
WC1

Drawing Title
Door Type H

Status
Construction

Date _____ Drawn _____ Scale _____
Mar 07 fc 1:10@A3

Job No. Drawing ref. Drawing No. Revision
3113 P(32) 152 -

DLG Architects
11-29 Fashion Street
London E1 6PZ

t +44(0)20 7426 3630
f +44(0)20 7426 3631
london@dlgarchitects.com

dlgarchitects.com



THIS DRAWING AND CAD DATA THEREIN
IS PROTECTED BY COPYRIGHT
AND MUST NOT BE COPIED OR REPRODUCED
WITHOUT THE WRITTEN CONSENT OF
DAMOND LOCK GRABOWSKI + PARTNERS.

©

NO DIMENSIONS ARE TO BE SCALED
FROM THIS DRAWING.
USE FIGURED DIMENSIONS ONLY.
ALL DIMENSIONS AND SIZES
ARE TO BE CHECKED ON SITE
AND ANY DISCREPANCIES REPORTED
TO THE ARCHITECT PRIOR TO
INITIATION OF ANY WORKS.

New flush door
Location:
Basement -
Electric cupboard under porch.
Finish:
painted off white to match
external rendering.

Date	Init.	Rev.

Job
**26/27 Bloomsbury Square
London
WC1**

Drawing Title
**Door -
Electric cupboard under porch**

Status
Planning

Date	Drawn	Scale
July 07	fc	1:10@A3

Job No.	Drawing ref.	Drawing No.	Revision
3113	P(32)	154	-

DLG Architects
11-29 Fashion Street
London E1 6PZ

t +44(0)20 7426 3630
f +44(0)20 7426 3631
london@dlgarchitects.com

dlgarchitects.com



2040 (to be verified on site)

823

829

