

PLAN

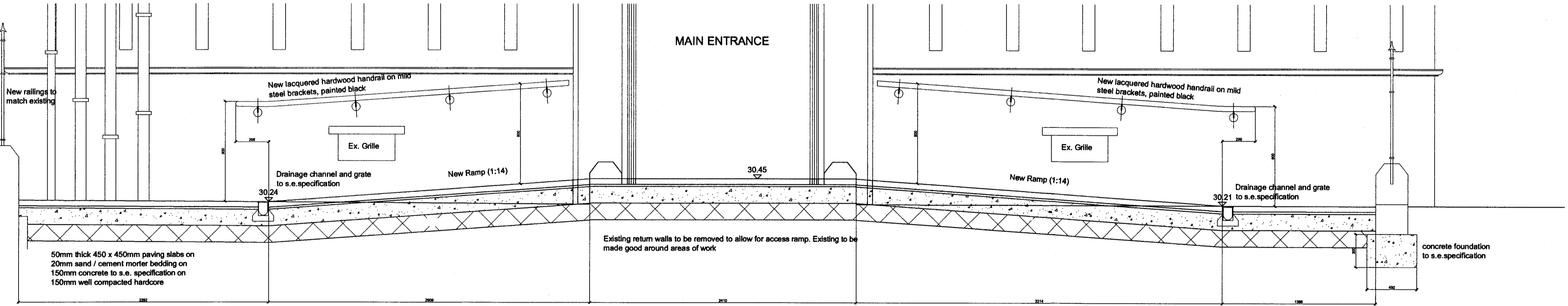

SECTION A

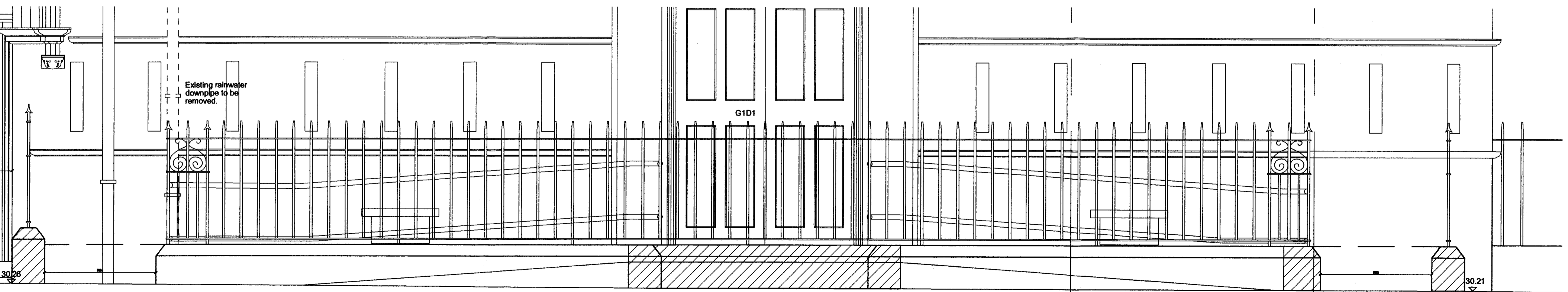

ELEVATION B

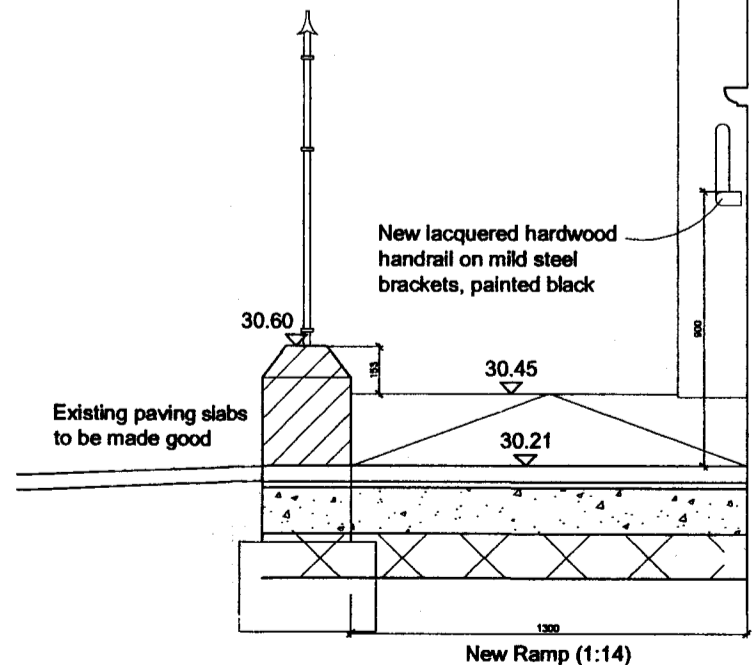

ELEVATION C

Notes
 All dimensions are in millimetres unless stated otherwise.
 All dimensions are to be checked on site.
 Do not scale from this drawing.
 This drawing is to be read in conjunction with all relevant documents and drawings.

Revision	Details	Author	Checked	Date
T5	General Updates & Planning Discharge Issue	CK		20.04.08
T4	Ramp section added, notes amended	SLV		05.10.08
T3	Amend to conservation officer's comments	CV		01.08.08
T2	Issued to conservation officer	JH		01.07.08
T1	Tender Issue	SYB		09.06.08

Δ Revisions

© This Drawing is copyright and must not be reproduced without the written consent of the architect.

Project
 Kentish Town Sports Centre

Drawing
 Proposed Entrance Ramps to Main Entrance

TENDER

Scale 1:25 @ A1	Project Number 877	Revision T5
Date 21 Apr '08	Drawing Number A(90)001	
Drawn CA	Checked	

Roberts Limbrick
 ARCHITECTS

ROBERTS LIMBRICK LIMITED
 CHEDWORTH HOUSE · FALCON CLOSE · BRISTOL ROAD
 QUEDGELEY · GLOUCESTER · GL2 4LY
 TEL: 03333 405 500 · FAX 03333 408 920